

**ERSATZTEILLISTE
SPARE PART LIST
LISTE DES PIÈCES RECHANGE**

**DE
EN
FR**

Corvus PKE 3011

**Kreiselegge,
Baureihe 1**

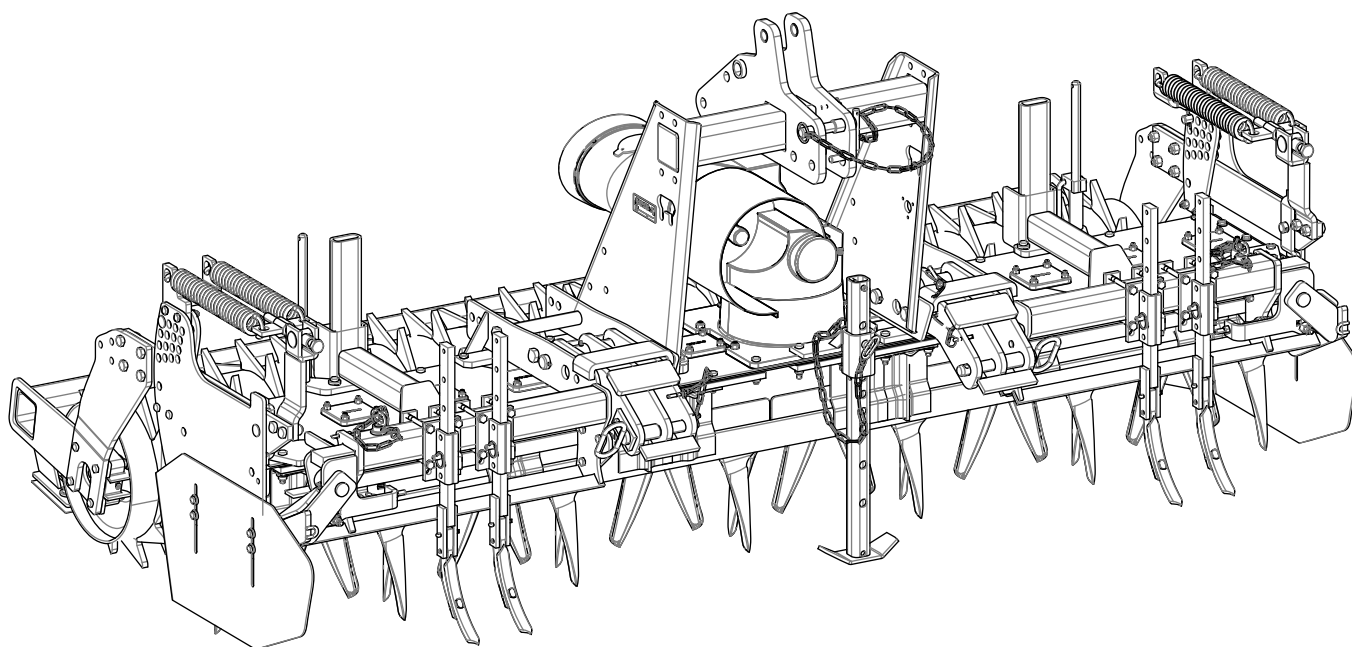

Wichtig bei Ersatzteilbestellungen

Bitte machen Sie bei jeder Bestellung folgende Angaben:

1. Maschinentype (auf Typenschild eingeschlagen).
2. Maschinenummer (auf Typenschild und Rahmen eingeschlagen).
3. Bestellnummer
4. Die gewünschte Stückzahl der Ersatzteile.

Important for ordering spare parts

Please give the following information whenever you order spare parts:

1. Type of the machine (stamped on type plate)
2. Serial number (stamped on type plate and frame)
3. Part number.
4. The required quantity of the spare parts.

Important pour la commande de pièces de rechange

Lors de chaque commande de pièces, veuillez nous communiquer les données suivantes:

1. Type de la machine (gravé sur la plaque d'identification).
2. Numéro de série de la machine (gravé sur la Plaque d'identification et le bâti).
3. Numéro de pièce.
4. La quantité nécessaire de pièces de rechange.

Typenschild / Identification Plate / Plaquette /



Inhaltsverzeichnis/ table of contents/ sommaire

PKE 3011 komplett	7
Werkzeugträger 3,0m	9
Seitenblechträger 3.0m Telesk. montiert	12
Seitenblech montiert	14
Unterenkeranbau Kat. 2 / 3	17
Oberlenker-Dreipunktanbau	19
Kreismesser KG-30M/30ML	21
Kreismesser RABID KG-30Z/30LZ	22
Kreismesser Multi-Fix Schnellwechselsystem KG-34	23
Segmenten-Schutzschiene vorn 3.0m komplett	26
.....	27
Lager-und Messerhalterschutz 3.0m	28
Wechselradgetriebe	29
Wechselgetriebe mit Durchtrieb 1 3/8 Zoll	31
Wechselgetriebe mit Durchtrieb 1 3/4 Zoll	35
Durchtrieb Nachrüstsatz 1 3/8 Zoll	39
Durchtrieb Nachrüstsatz 1 3/4 Zoll	40
Schutz für Durchtrieb	41
Gelenkwelle Nockenkupplung (GKN)	42
Nockenschaltkupplung	43
Gelenkwelle Reibkupplung (BYPY)	44
Lagerarme komplett Walze D<540mm	45
Lagerarme komplett Walze D>550mm	46
Stabpackerwalze D540 3,0m komplett	47
Zahnpackerwalze GZW 510-125 3.0m komplett	48
.....	49
.....	50
Abstreifer GZW unbeschichtet komplett	51
Abstreifer GZW beschichtet komplett	52
MPW 500 /2 3.0m Abstreifer unten komplett	53
MPW 500 /2 3.0m Walze und Lager komplett	54
MPW 500 /2 3.0m Abstreiferbalken komplett	55
MPW 500 /2 Abstreiferblech Dual M12 Set Standard	56
MPW 500 /2 Abstreiferblech Dual M12 Set Variante	57
Ripa-O 580 3.0m Abstreifer unten komplett	58
Ripa-O 580 3.0mWalze und Lager komplett	59
Ripa-O 580 3.0m Abstreiferbalken komplett	60
Abstreiferblech Standard Ripa O komplett	61
Abstreiferblech Variante Ripa O komplett	62
Walzen Abstützung, gefedert, 4 Federn	63
Abstellstütze komplett	64

Turmabstützung PKE 3.0m	65
Prallblech 3.0m.....	66
Prallblech Halter	67
Radspurlockerer starr 80er Rohr komplett	68
Radspurlockerer gefedert 80er Rohr komplett.....	69
Radspurlockerer starr und Gänsefuß komplett.....	70
Radspurlockerer Ramat komplett.....	71
Segmenten-Schutzschiene hinten 3.0m komplett.....	73
Dreipunktgestänge mechanisch	74
Drill Lift	76
Drill Lift Anbauteile.....	79
Drill Lift, Hydraulischer Aushub	81
Drill Lift Hubbegrenzung	83
Satteldreieck PKE montiert	84
Satteldreieck für Fremdfabrikate	85
Frontanbau	86
Gelenkwellen Frontanbau	90
Beleuchtung PKE 3.0m	91
Anbauset Beleuchtung Frankreich	95

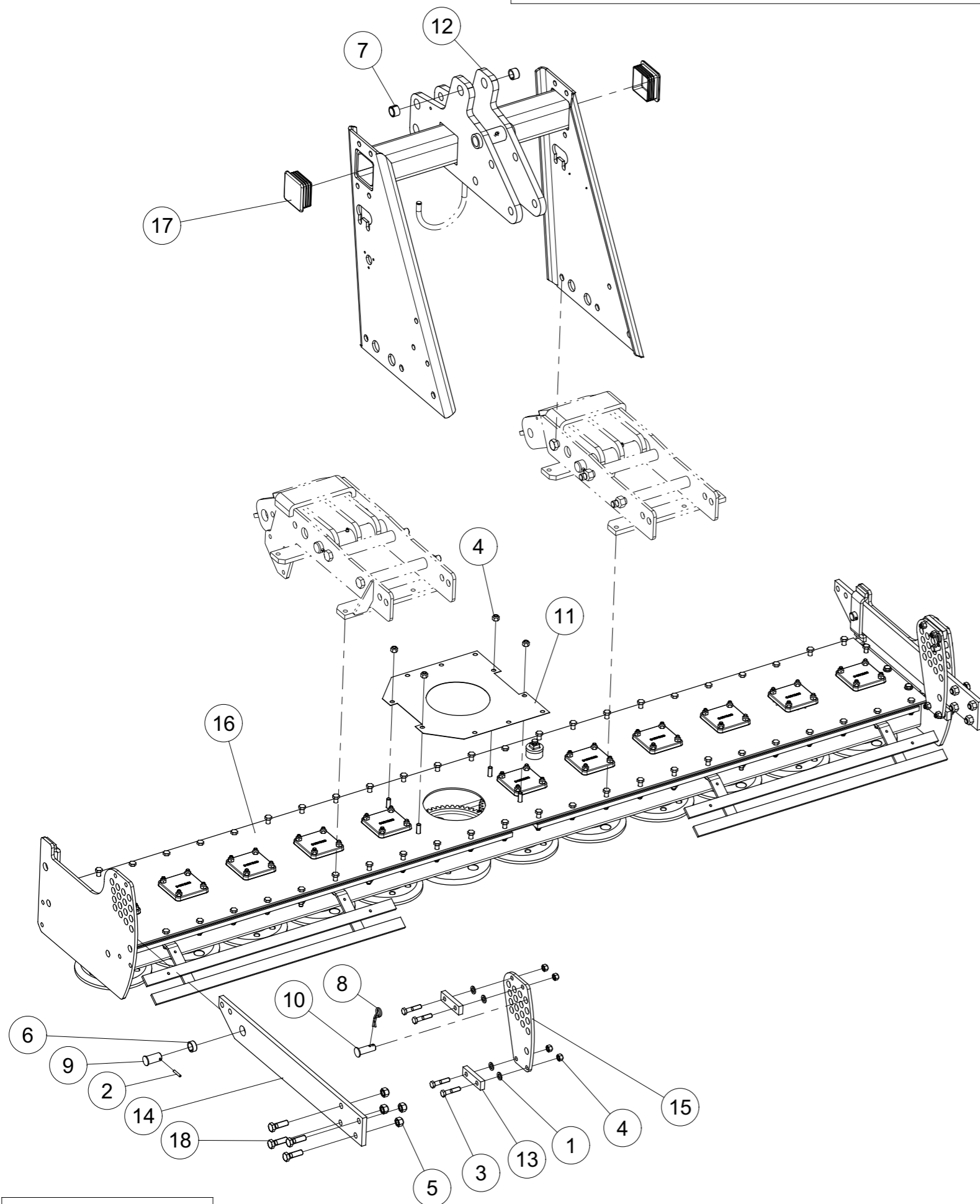

Pos. / Index	Stck. / Qty	Artikel-Nr.	Benennung / Designation
1	8	126D14	SCHEIBE 14 ISO7091 Washer 14 ISO7091 Rondelle 14 ISO7091
2	2	1481D636A	SPANNSTIFT 6 X 36 ISO8752 VERZ. Spring Pin 6 X 36 ISO8752 Z Goupille elastique 6 X 36 ISO8752 Z
3	8	931D1255NA	Hex. Schraube M12 x 55 Verzinkt 10.9 Hex. Screw M12 x 55 Zinc 10.9 Vis H M12 x 55 ZNBL 10.9
4	12	980DV12NA	Sicherungsmutter M12 Verzinkt 10.9 Nut M12 Zinc 10.9 Ecrou M12 ZNBL 10.9
5	8	980DV1615NA	Sicherungsmutter M16x1.5 Verzinkt 10.9 Nut M16x1.5 Zinc 10.9 Ecrou M16x1.5 ZNBL 10.9
6	2	1498D253214	BUCHSE EG 25/32x14 DIN1498
7	2	1498D253220	BUCHSE EG 25/32x20 DIN1498
8	2	11024D4A	FEDERSTECKER-11024 4 Z DW
9	2	8409.99.01	Steckbolzen D25-42 verg.
10	2	8409.99.02	Steckbolzen D20-42 verg.
11	1	8437.00.30	Getriebedichtung
12	1	8438.11.03	Turm gs. Kat IV N
13	4	8438.36.12	Lasche D13-60
14	2	8444.00.16	Seitenarm
15	2	8446.00.12	Platte
16	1	8446.03.02	Werkzeugträger 3.0m mont.
17	2	9037.49.70	Lamellenstopfen LQ100x100x5-8
18	8	960D161550NA	Hex. Schraube M16x1.5x50 Verzinkt Hex. Screw M16x1.5x50 ZNBL Vis hex. M16x1.5x50 ZNBL

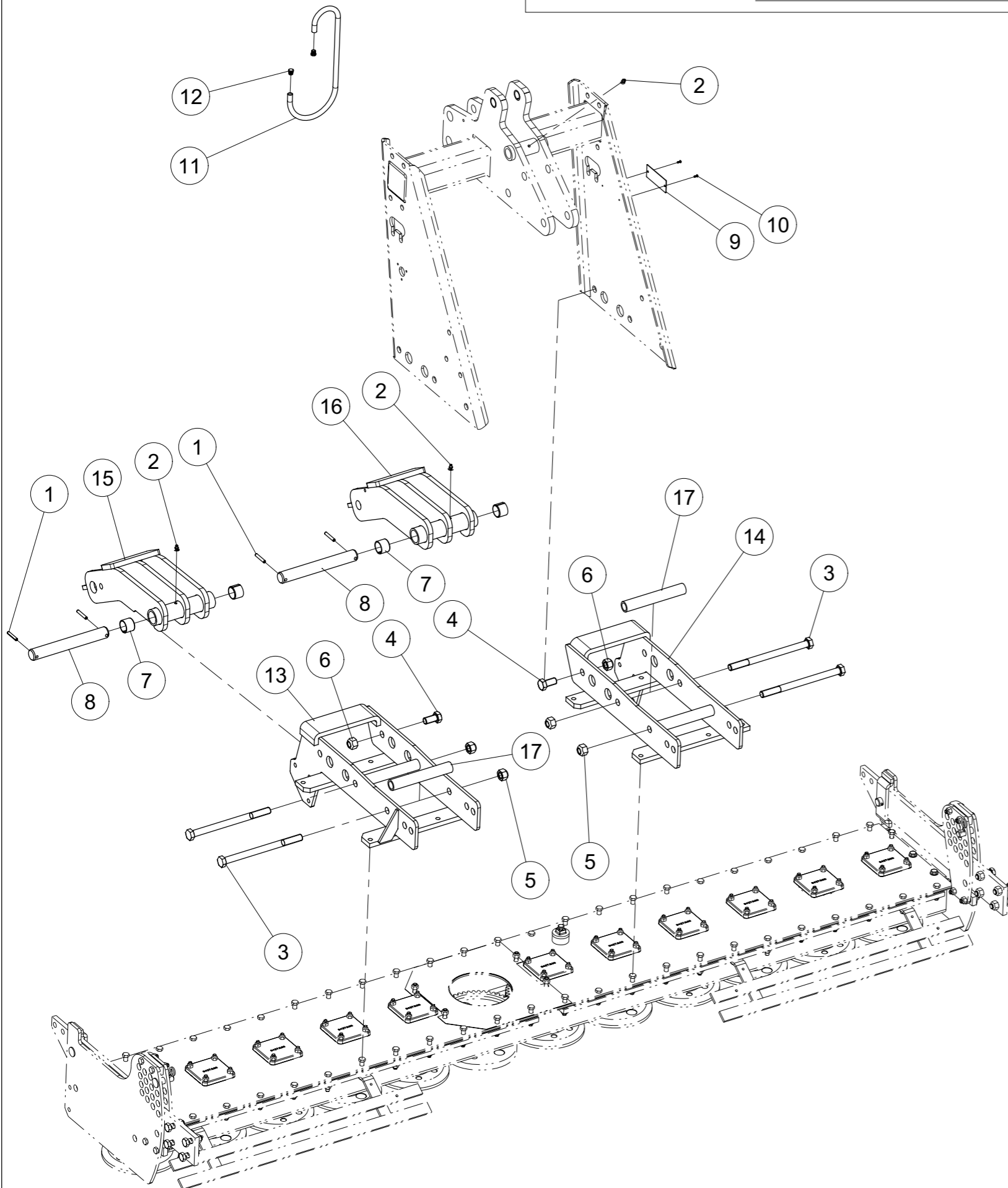

Pos. / Index	Stck. / Qty	Artikel-Nr.	Benennung / Designation
1	4	1481D850A	SPANNSTIFT 8 X 50 ISO8752 VERZ. Spring Pin 8 X 50 ISO8752 Z Goupille elastique 8 X 50 ISO8752 Z
2	3	71412DA81	SCHMIERNIPPEL H1-M 8x1 -180 Grease Nipple H1-M 8x1 -180 Graisseur H1-M 8x1 -180
3	4	931D20280NA	Hex. Schraube M20 x 280 Verzinkt 10.9 Hex. Screw M20 x 280 Zinc 10.9 Vis H M20 x 280 ZNBL 10.9
4	2	933D2040PA	hex. Schraube M20x40 ISO4017-8.8 verzinkt Hex. Screw M20x40 ISO4017-8.8 Zinc Vis H M20x40 ISO4017-8.8 ZNBL
5	4	980DV20NA	Sicherungsmutter M20 Verzinkt 10.9 Nut M20 Zinc 10.9 Ecrou M20 ZNBL 10.9
6	2	980DV20PA	Sicherungsmutter M20 Verzinkt 8.8 Nut M20 Zinc 8.8 Ecrou M20 ZNBL 8.8
7	4	1498D354030	BUCHSE EG 35/40x30 DIN1498
8	2	1000.13.34	Bolzen D35-Zwl 252 verg.verz.
9	1	1000.99.04	Typenschild CE (Besson)
10	2	1476D410A	KERBNAGEL 4x10 DIN1476 Z
11	1	8405.00.19	Buegel
12	2	8405.00.34	Lamellenstopfen 32OGL15
13	1	8437.68.26	Turmhalterung li. Kat. 4N
14	1	8437.68.27	Turmhalterung re. Kat.- 4N
15	1	8437.69.28	Anlenkung li. Kat.4N
16	1	8437.69.29	Anlenkung re. Kat.4N
17	4	8446.03.12	SR33745X214X

Werkzeugträger 3.0m mont.

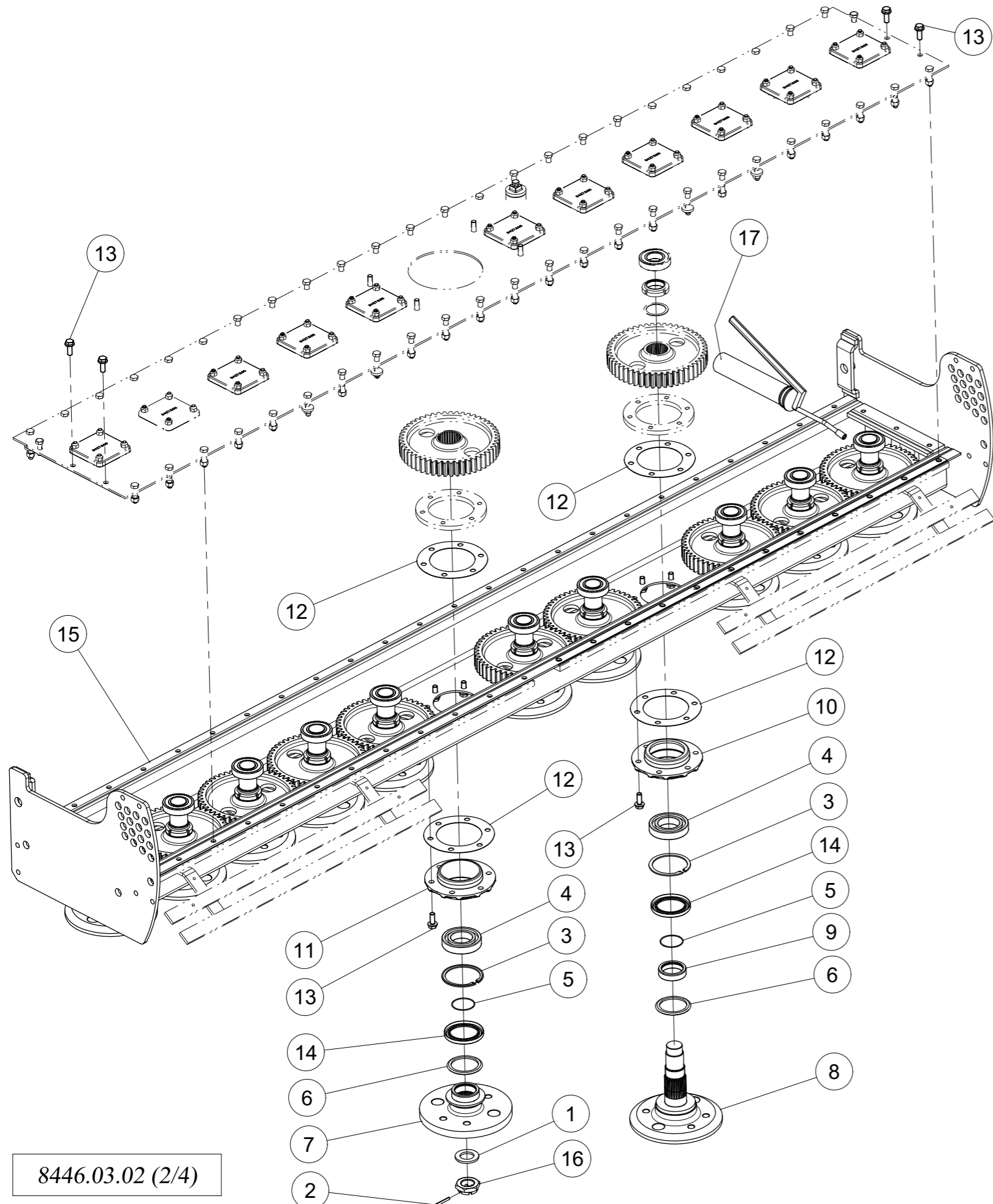

Pos. / Index	Stck. / Qty	Artikel-Nr.	Benennung / Designation
1	1	126D36A	SCHEIBE 36 ISO7091 Z Washer 36 ISO7091 ZNBL Rondelle 36 ISO7091 ZNBL
2	1	1481D650	SPANNSTIFT 6 X 50 ISO8752 Spring Pin 6 X 50 ISO8752 Goupille elastique 6 X 50 ISO8752
3	12	472D1003	SICHERUNGSR.100x3 DIN472
4	12	625D6211	R.kugellager-625 6211
5	12	8404.26.06	O-Ring 55x2
6	12	8404.27.00	GAMMA Ring Typ RB 70/90/5.5
7	1	8413.00.14	Messerhalter
8	11	8413.00.17	Welle mit Messerhalter links
9	11	8413.00.18	Lauftring
10	11	8413.00.20	Lagerflansch
11	1	8413.00.21	Lagerflansch Mitte
12	24	8413.00.23	Lagerflanschdichtung D180x116
13	76	8426.13.07	VERBUS-RIPP-SCHRAUBE-M12x30
14	12	8433.00.13	Wellendichtring 70 / 100 / 10
15	1	8446.01.02	Werkzeugträger 3.0m
16	1	937D3615PA	KRONENMUTTER M36x1,5 DIN937-8 Verzinkt Castellated nut M36x1,5 DIN937-8 Zinc. Ecrou à creneaux M36x1,5 DIN937-8 ZNBL
17	1	FLIESSFETT_2	FLIESSFETT_2 1.5kg/kreisel

Pos. ⑤ 250 Nm + Loctite
 Montagedrehmoment + flüssige Schraubensicherung
 mounting torque + liquid thread lock
 Serage suivant Couple indique + Colle

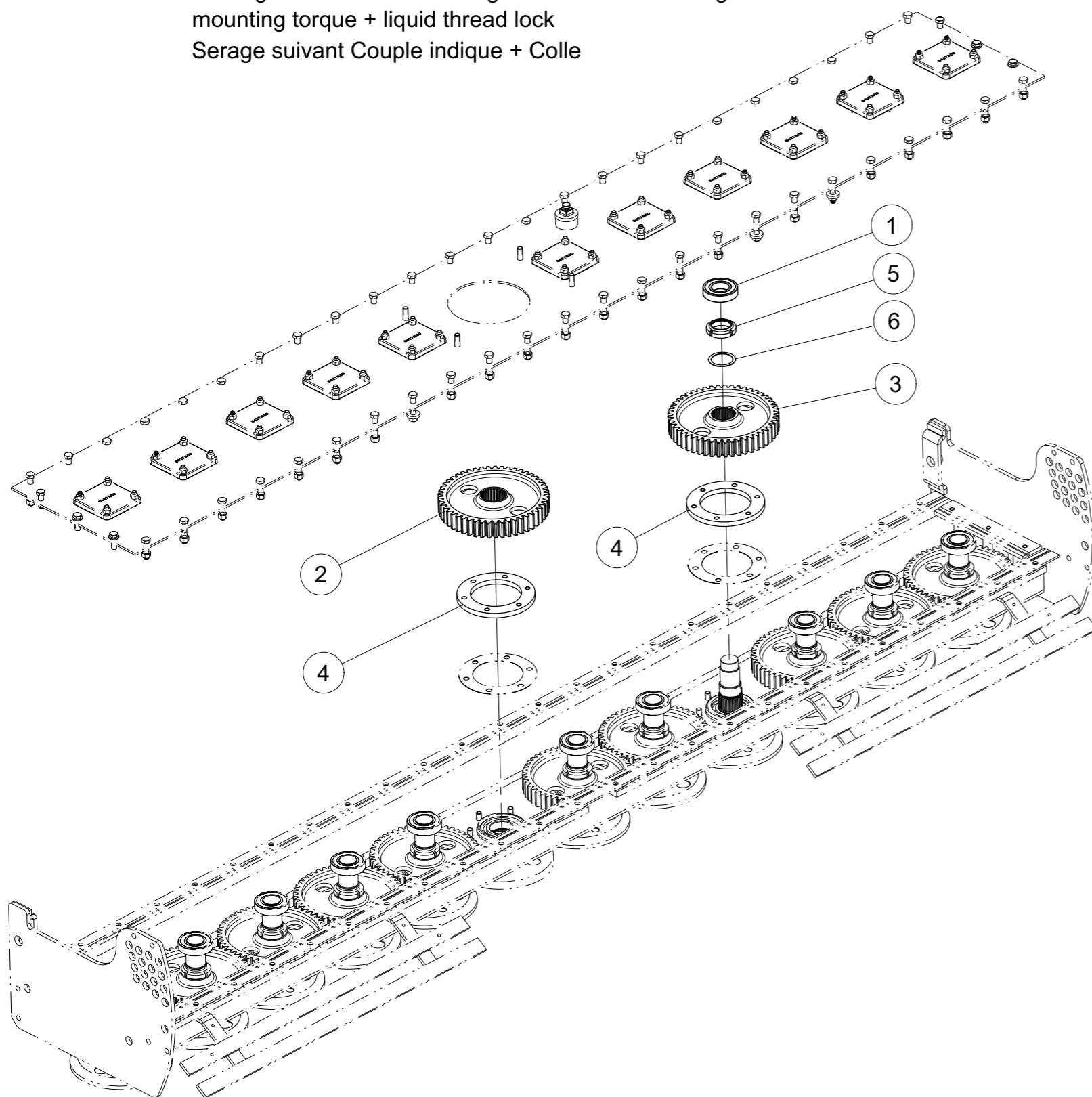

Pos. / Index	Stck. / Qty	Artikel-Nr.	Benennung / Designation
1	11	625D62082RS	R.kugellager-625 6208 2RS
2	1	8413.00.11	Zahnrad Z=49 -mitte-
3	11	8413.00.15	Zahnrad Z=49
4	12	8413.00.22	Bodenverstärkung
5	11	8413.00.32	Nutmutter PM50X1.5 SSN 546
6	11	988D50621	PASSSCHEIBEN 50x 62x1 DIN988

Werkzeugträger 3.0m mont.

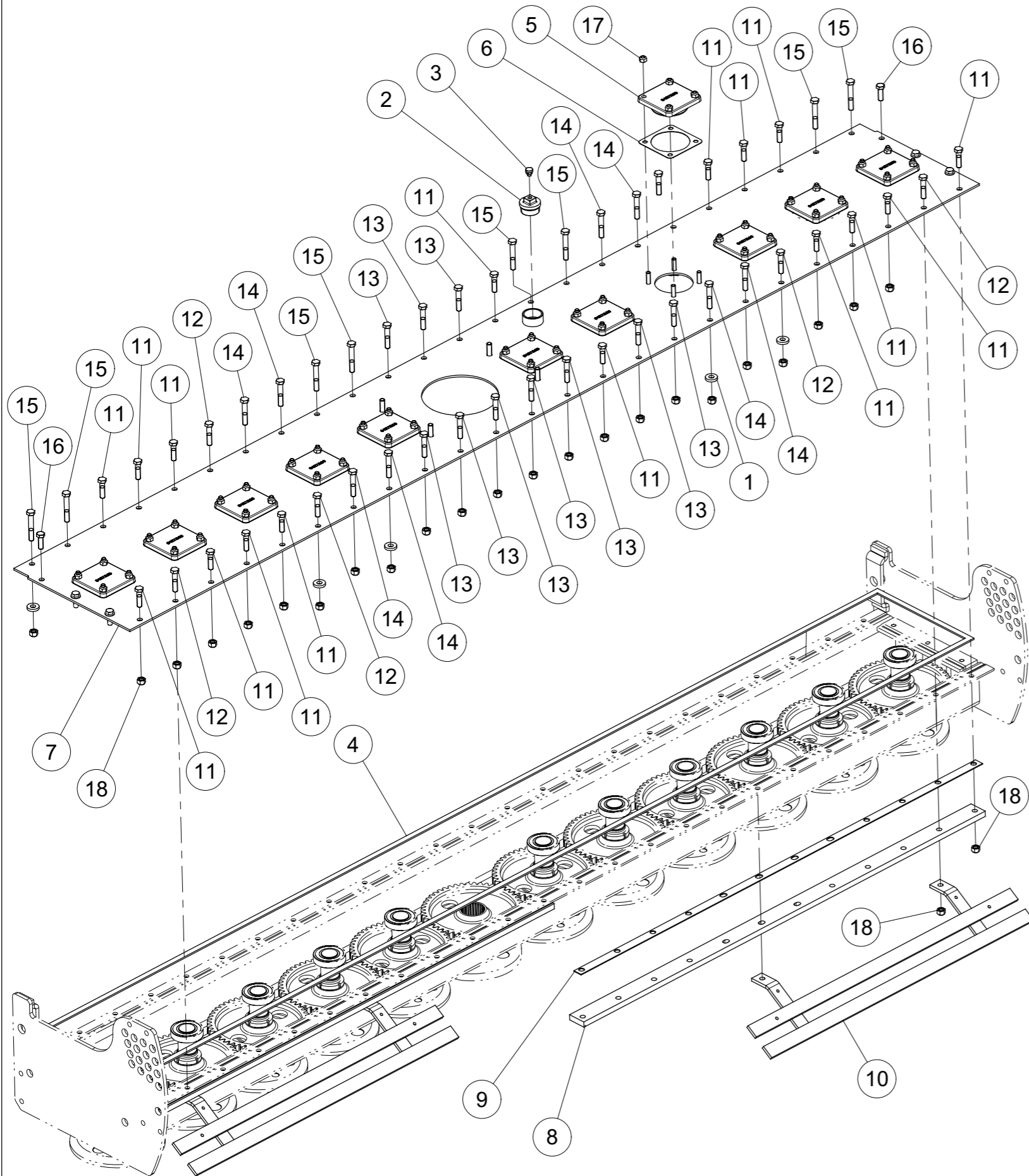

Pos. / Index	Stck. / Qty	Artikel-Nr.	Benennung / Designation
1	18	7349D13A	SCHEIBE 13 DIN7349 verzinkt
2	1	8404.24.00	Verschlusschraube R1 1/2"
3	1	8404.47.00	Be- und Entlüftungfilter
4	1	8409.31.00	Flachdichtung 15x4 629Olg.
5	11	8427.11.00	Lagerdeckel
6	11	8427.12.00	Lagerdeckeldichtung
7	1	8427.39.06	Abdeckblech 3.0m gs.
8	4	8437.00.60	Leiste
9	4	8437.00.67	Leiste 138Olg. (122.5)
10	2	8438.29.10	Beinschutz hinten geschweißt
11	16	931D1245NA	Hex. Schraube M12 x 45 Verzinkt 10.9 Hex. Screw M12 x 45 Zinc 10.9 Vis H M12 x 45 ZNBL 10.9
12	6	931D1255M	Hex. Schraube M12 x 55 Blank 12.9 Hex. Screw M12 x 55 Black 12.9 Vis H M12 x 55 Noire 12.9
13	10	931D1260NA	Hex. Schraube M12 x 60 Verzinkt 10.9 Hex. Screw M12 x 60 Zinc 10.9 Vis H M12 x 60 ZNBL 10.9
14	8	931D1265NA	Hex. Schraube M12 x 65 Verzinkt 10.9 Hex. Screw M12 x 65 Zinc 10.9 Vis H M12 x 65 ZNBL 10.9
15	8	931D1275NA	Hex. Schraube M12 x 75 Verzinkt 10.9 Hex. Screw M12 x 75 Zinc 10.9 Vis H M12 x 75 ZNBL 10.9
16	2	933D1235NA	hex. Schraube M12x35 ISO4017-10.9 verzinkt Hex. Screw M12x35 ISO4017-10.9 Zinc Vis H M12x35 ISO4017-10.9 ZNBL
17	44	980DV10NA	Sicherungsmutter M10 Verzinkt 10.9 Nut M10 Zinc 10.9 Ecrou M10 ZNBL 10.9
18	48	980DV12NA	Sicherungsmutter M12 Verzinkt 10.9 Nut M12 Zinc 10.9 Ecrou M12 ZNBL 10.9

Seitenblechträger 3.0m telesk.

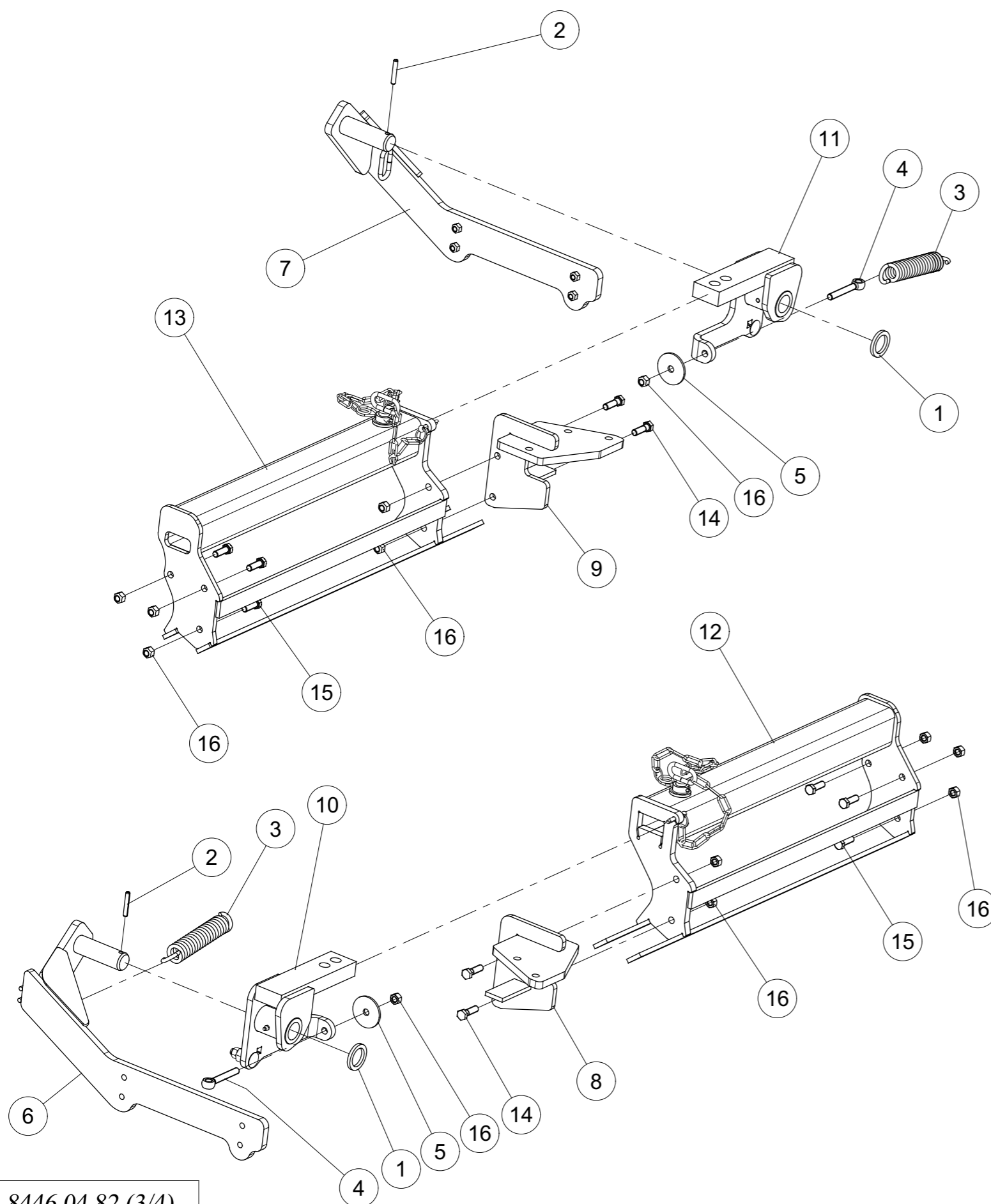

Pos. / Index	Stck. / Qty	Artikel-Nr.	Benennung / Designation
1	2	1441D37A	SCHEIBE 37 DIN1441 Z
2	2	1481D850A	SPANNSTIFT 8 X 50 ISO8752 VERZ. Spring Pin 8 X 50 ISO8752 Z Goupille elastique 8 X 50 ISO8752 Z
3	2	6241.41.09	Zugfeder CF-244
4	2	6241.94.04	Augenschraube M12X90
5	2	8434.29.09	Scheibe
6	1	8446.04.21	Seitenblechträger li. gs.
7	1	8446.04.22	Seitenblechträger re. gs.
8	1	8446.04.25	Abstützung li. gs.
9	1	8446.04.26	Abstützung re. gs.
10	1	8446.04.27	Seitenblechträger li. gs.
11	1	8446.04.28	Seitenblechträger re. gs.
12	1	8446.06.29	Halter li. gs.
13	1	8446.06.30	Halter re. gs.
14	4	931D1240NA	Hex. Schraube M12 x 240 Verzinkt 10.9 Hex. Screw M12 x 240 Zinc 10.9 Vis H M12 x 240 ZNBL 10.9
15	6	933D1235NA	hex. Schraube M12x35 ISO4017-10.9 verzinkt Hex. Screw M12x35 ISO4017-10.9 Zinc Vis H M12x35 ISO4017-10.9 ZNBL
16	12	980DV12NA	Sicherungsmutter M12 Verzinkt 10.9 Nut M12 Zinc 10.9 Ecrou M12 ZNBL 10.9

8446.04.82 (3/4)

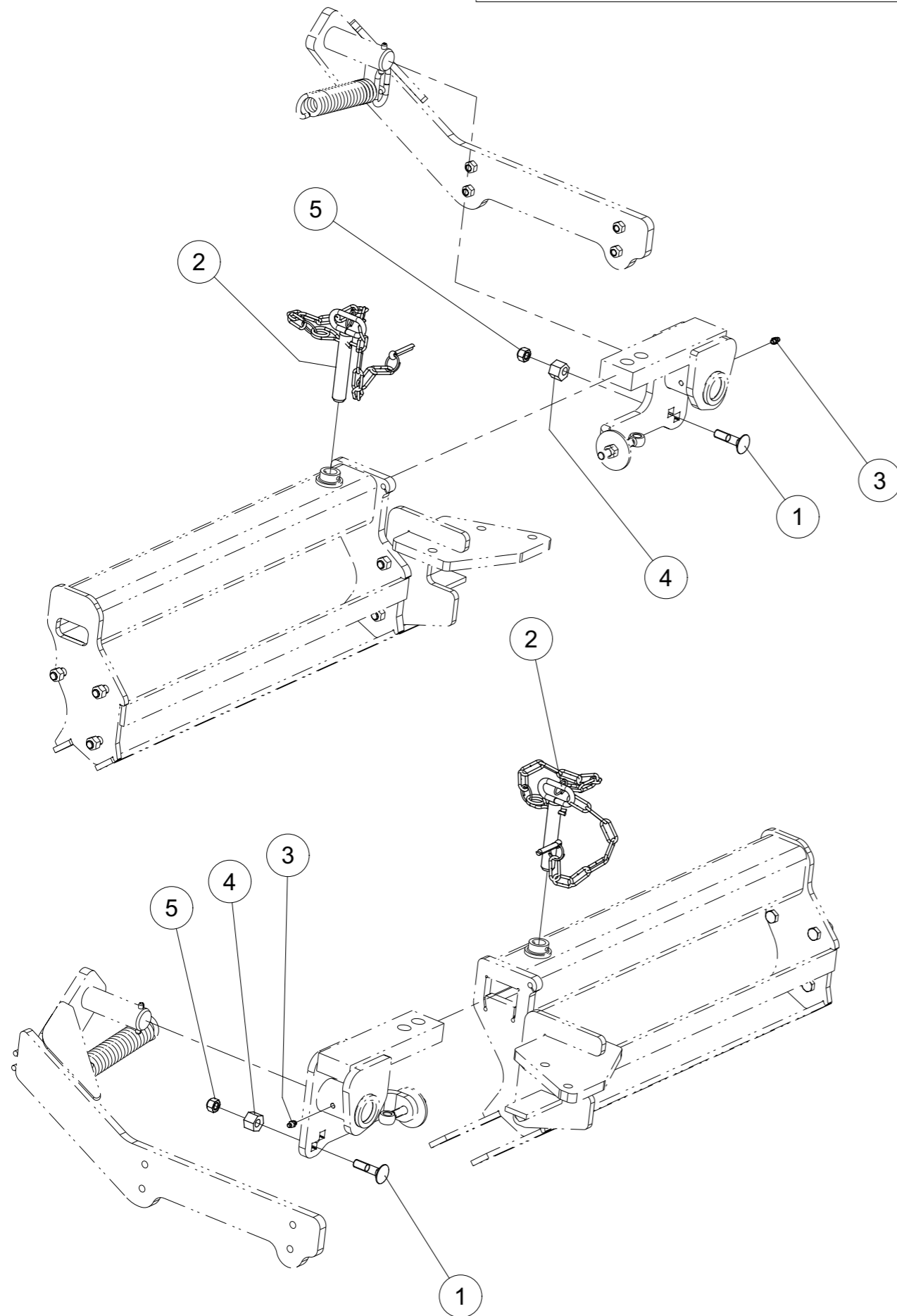

Pos. / Index	Stck. / Qty	Artikel-Nr.	Benennung / Designation
1	2	603 D1250 PA	FL_RD_S. M12x50 ISO8677-8.8 Z Round-head bolt M12x50 ISO8677-8.8 Z Vis TRCC M12x50 ISO8677-8.8 ZNBL
2	2	1000.20.21	Steckbolzen Ø20 mont.
3	2	71412DA81	SCHMIERNIPPEL H1-M 8x1 -180 Grease Nipple H1-M 8x1 -180 Graisseur H1-M 8x1 -180
4	2	8446.04.54	Exzenter
5	2	980DV12PA	Sicherungsmutter M12 Verzinkt 8.8 Nut M12 Zinc 8.8 Ecrou M12 ZNBL 8.8

Pos. / Index	Stck. / Qty	Artikel-Nr.	Benennung / Designation
1	1	8446.04.78	Seitenblech links mont.
2	1	8446.04.79	Seitenblech rechts mont.

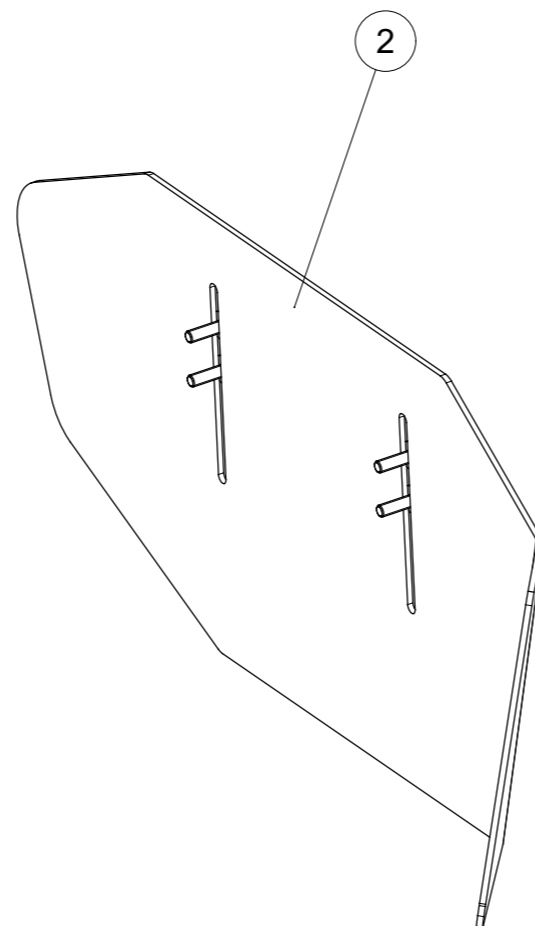
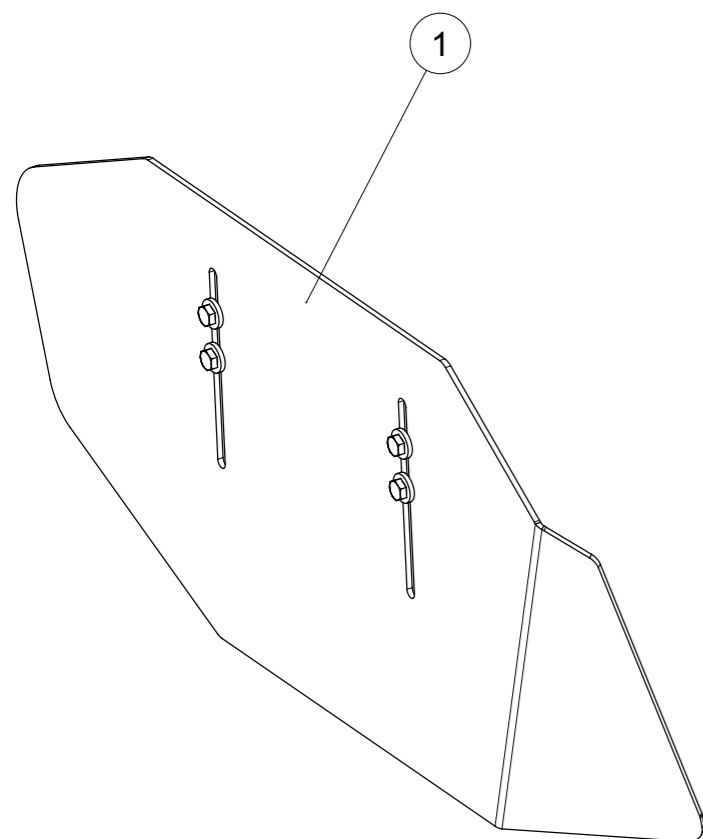

Seitenblech links mont.

Pos. / Index	Stck. / Qty	Artikel-Nr.	Benennung / Designation
1	4	933D1035PA	hex. Schraube M10x35 ISO4017-8.8 verzinkt Hex. Screw M10x35 ISO4017-8.8 Zinc Vis H M10x35 ISO4017-8.8 ZNBL
2	4	7349D10.5A	SCHEIBE 10,5 DIN7349 verzinkt
3	1	8446.00.14	Steitenblech links

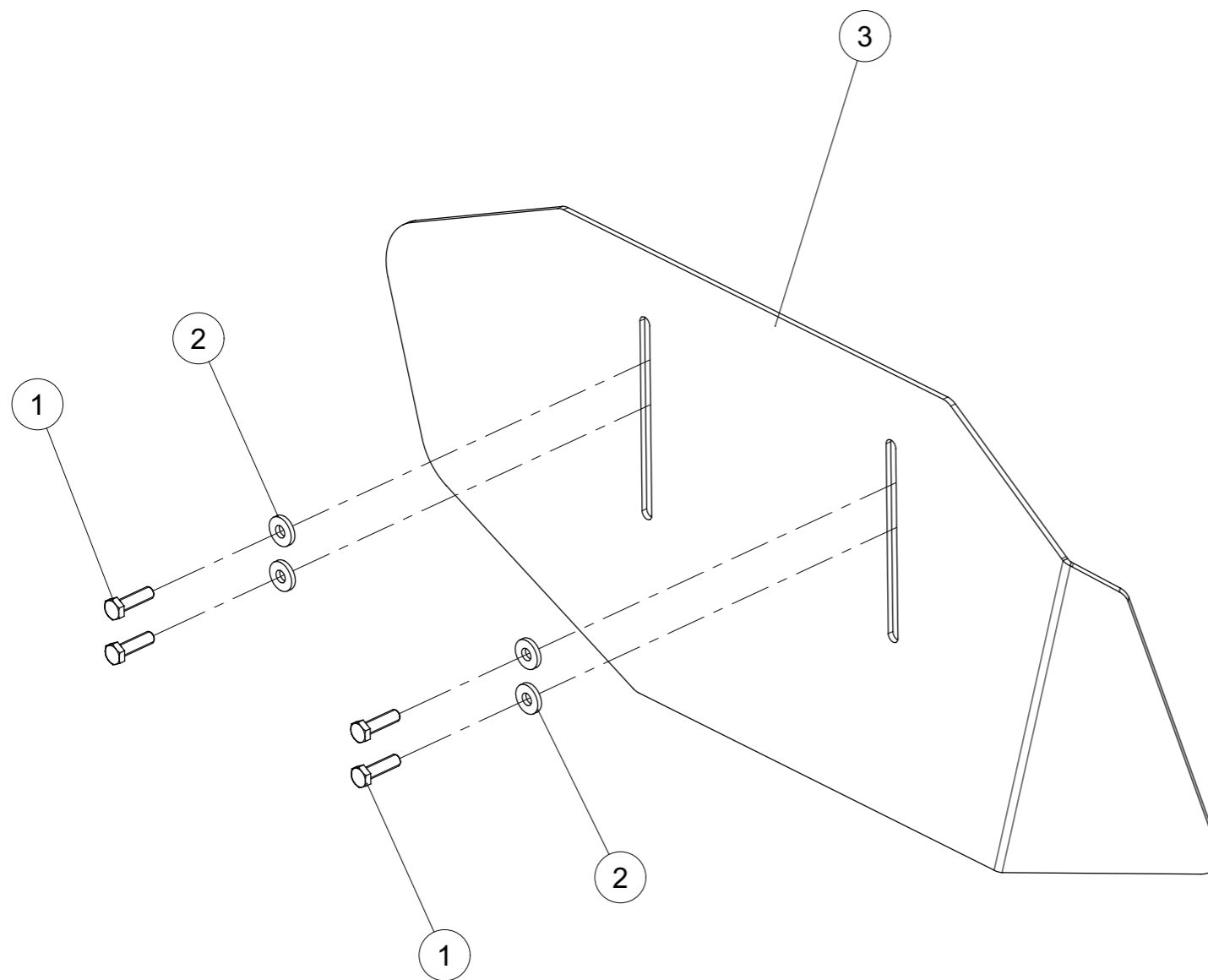

Seitenblech rechts mont.

Pos. / Index	Stck. / Qty	Artikel-Nr.	Benennung / Designation
1	4	933D1035PA	hex. Schraube M10x35 ISO4017-8.8 verzinkt Hex. Screw M10x35 ISO4017-8.8 Zinc Vis H M10x35 ISO4017-8.8 ZNBL
2	4	7349D10.5A	SCHEIBE 10,5 DIN7349 verzinkt
3	1	8446.00.15	Steitenblech rechts

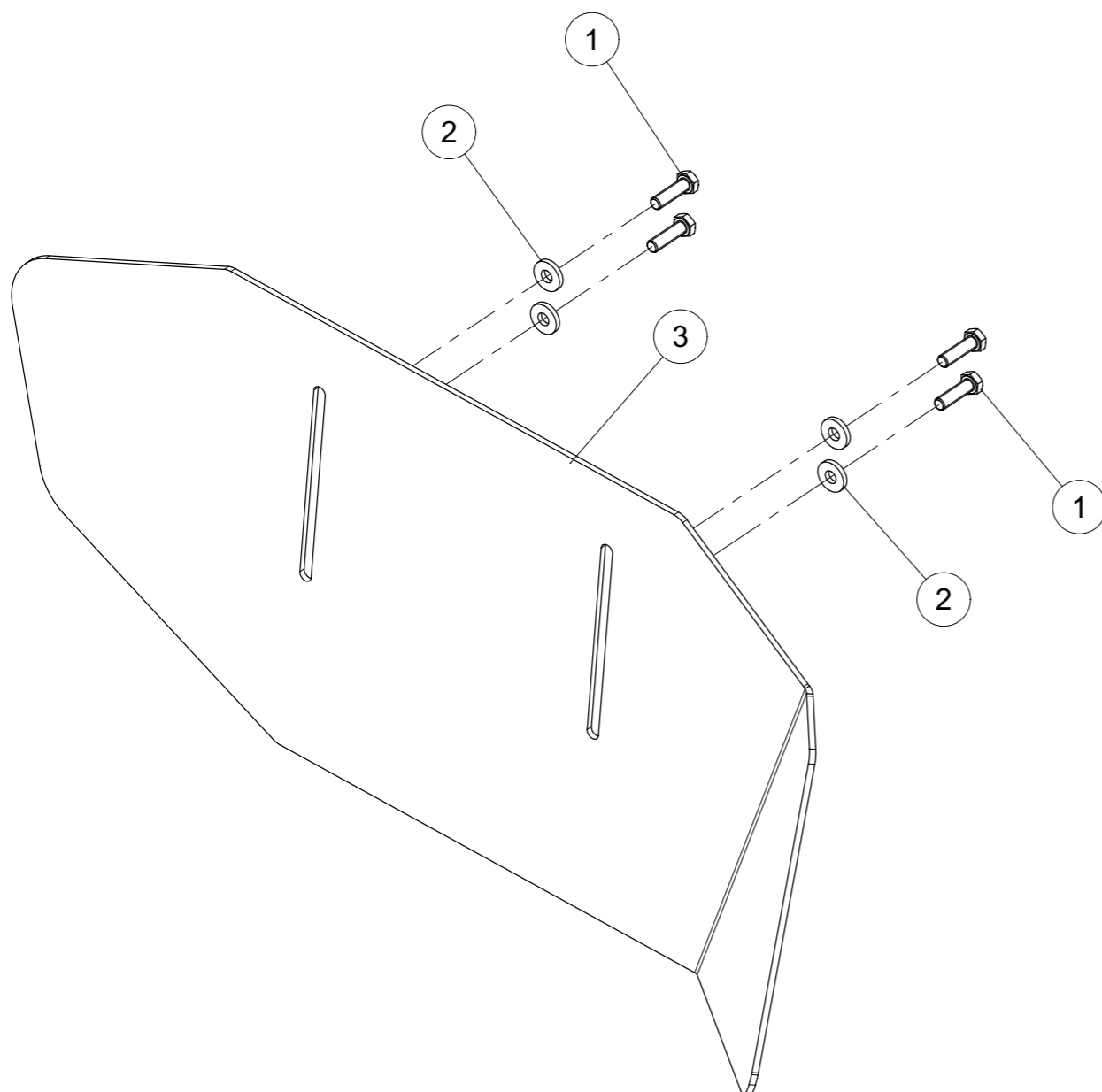

Pos. / Index	Stck. / Qty	Artikel-Nr.	Benennung / Designation
1	2	6344.40.03	Sicherungskette Kat. 2
2	2	8432.75.26	Unterlenkerbolzen für Kat. 4N
3	2	94D840A	SPLINT 8x 40 ISO1234 Z cotter pin 8x 40 ISO1234 Z

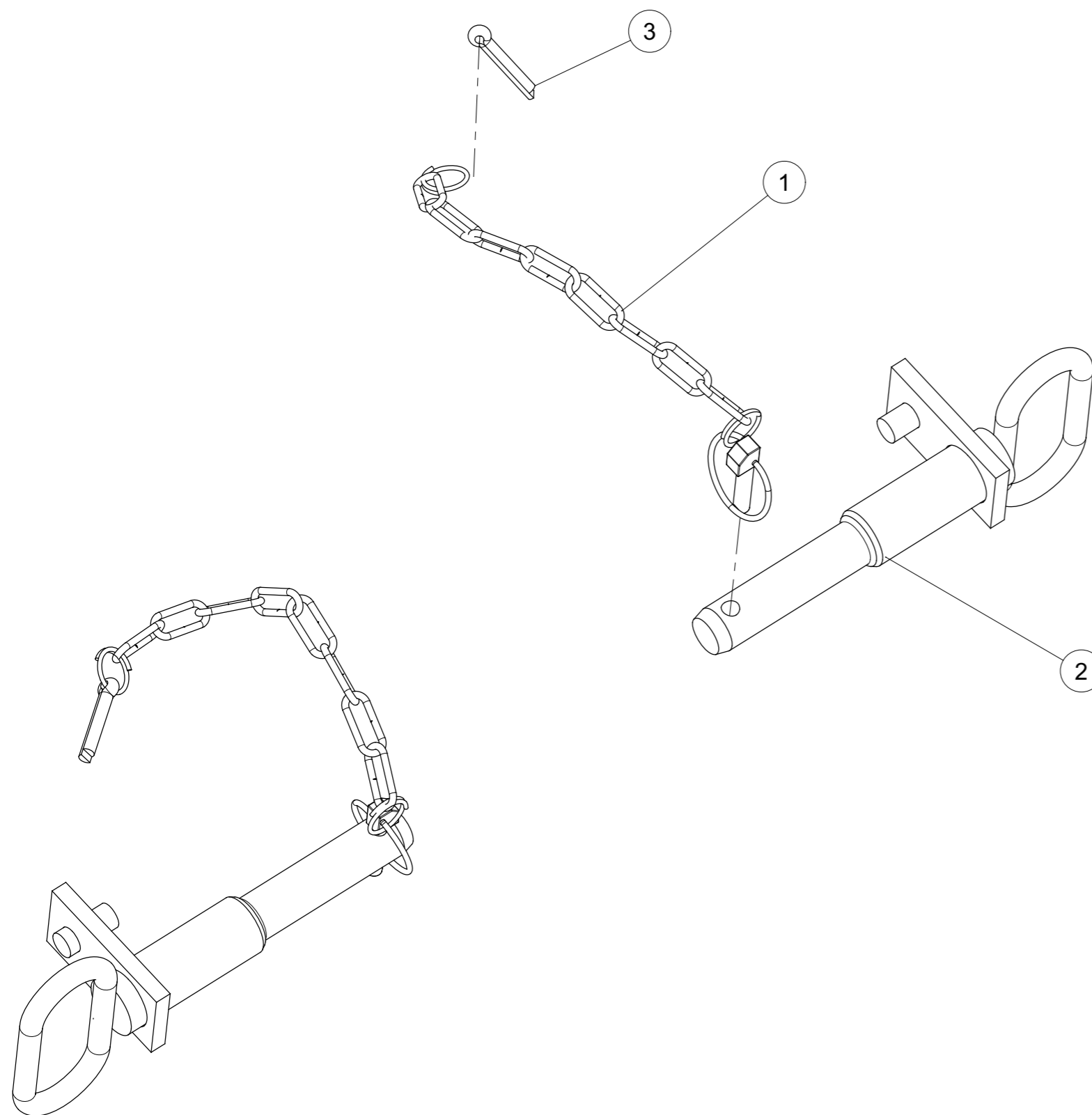

Pos. / Index	Stck. / Qty	Artikel-Nr.	Benennung / Designation
1	2	6344.40.03	Sicherungskette Kat. 2
2	2	8432.45.01	Reduzierbuchse 28/36x50
3	2	8432.75.26	Unterlenkerbolzen für Kat. 4N
4	2	94D840A	SPLINT 8x 40 ISO1234 Z cotter pin 8x 40 ISO1234 Z Goupille fendue 8x 40 ISO1234 Z

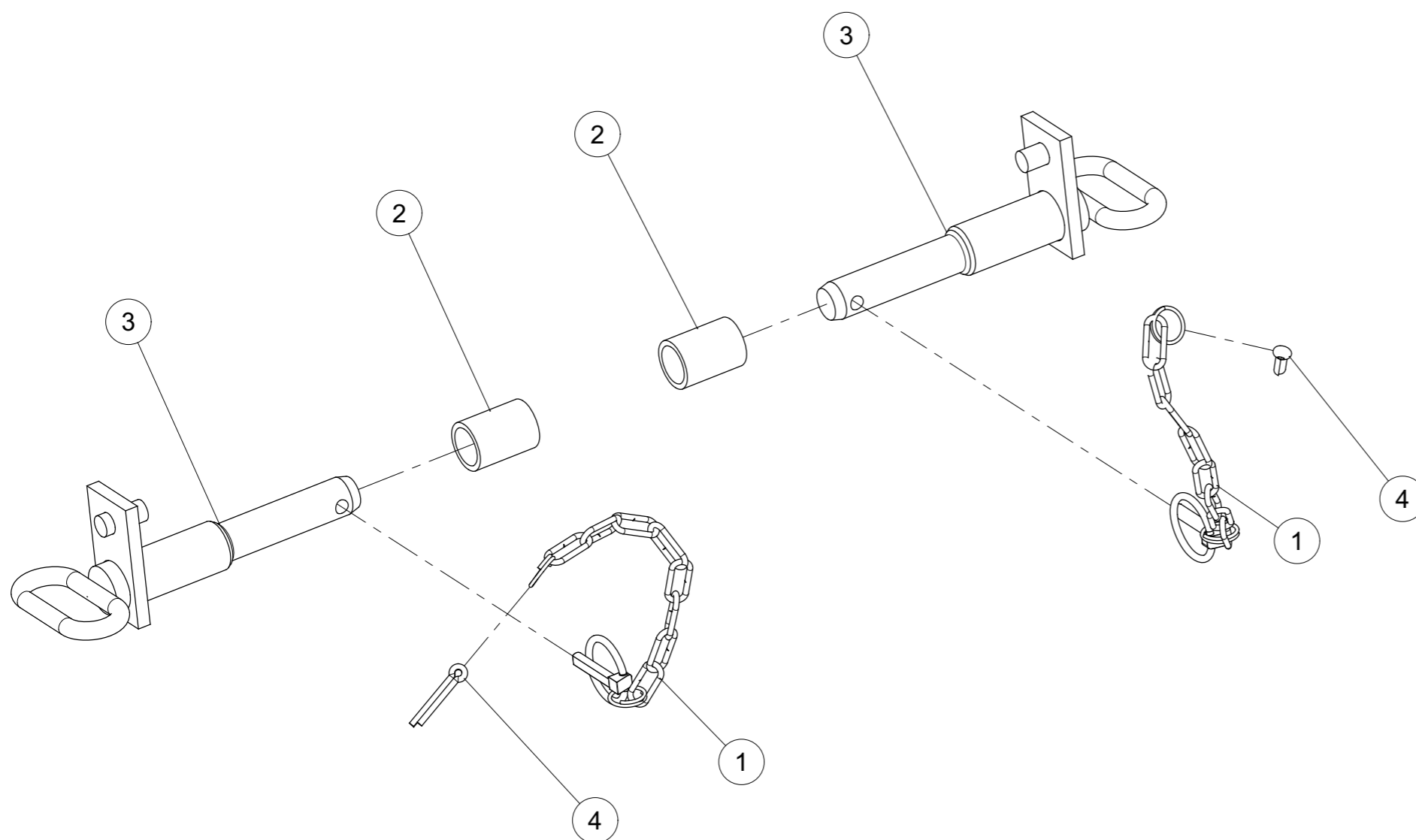

Pos. / Index	Stck. / Qty	Artikel-Nr.	Benennung / Designation
1	1	94D840A	SPLINT 8x 40 ISO1234 Z cotter pin 8x 40 ISO1234 Z
2	1	5296DA252,5A	Federring
3	1	5685D0.128G3A	Kette G3 O.128m 8 Glieder
4	1	8413.31.00	Oberlenkerstock Kat. II

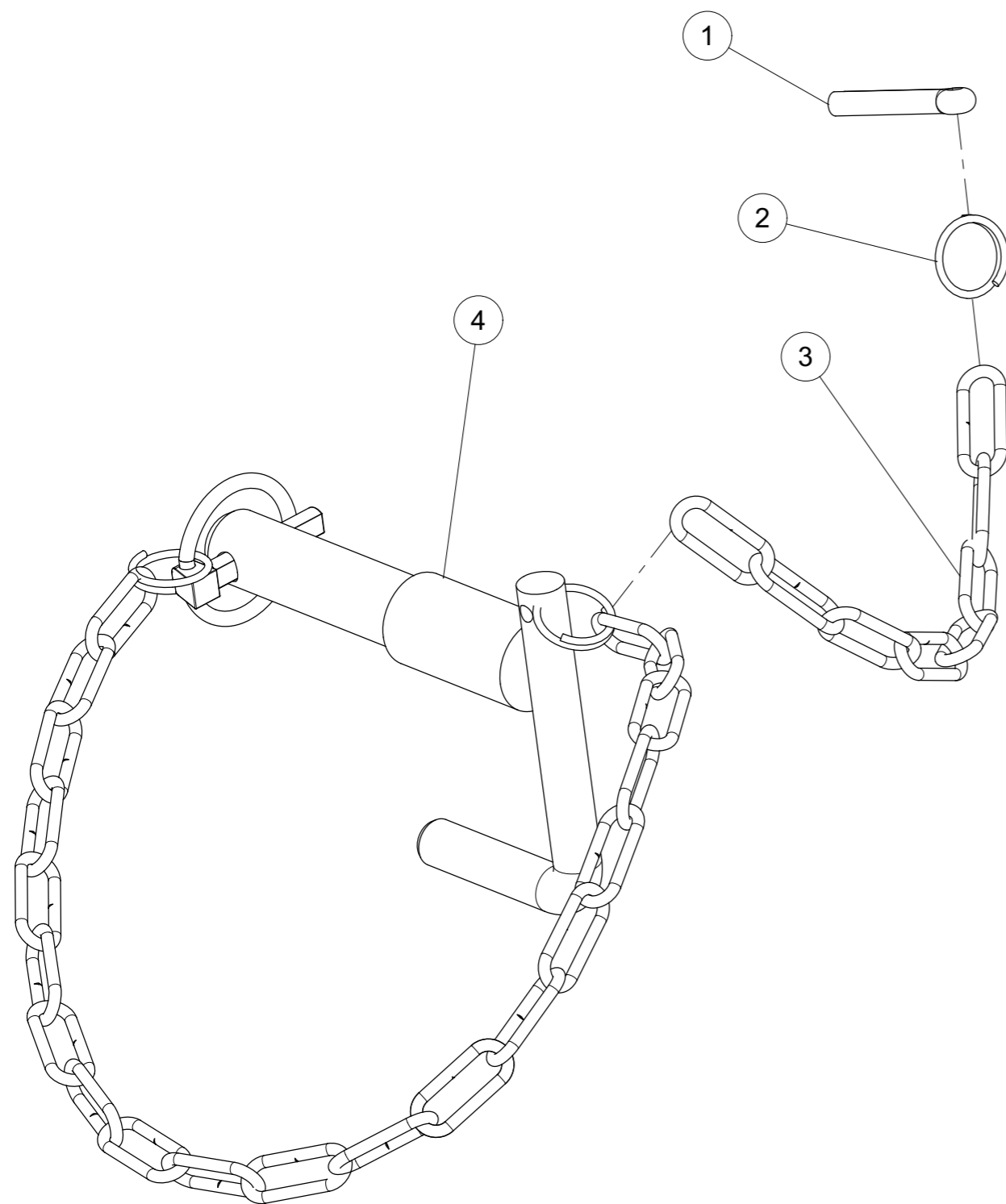

Pos. / Index	Stck. / Qty	Artikel-Nr.	Benennung / Designation
1	1	94D840A	SPLINT 8x 40 ISO1234 Z cotter pin 8x 40 ISO1234 Z
2	1	5296DA252,5A	Federring
3	1	5685D0.128G3A	Kette G3 O.128m 8 Glieder
4	1	8413.31.00	Oberlenkerstock Kat. II
5	1	8437.27.23	OL-Kugel Kat.III/II

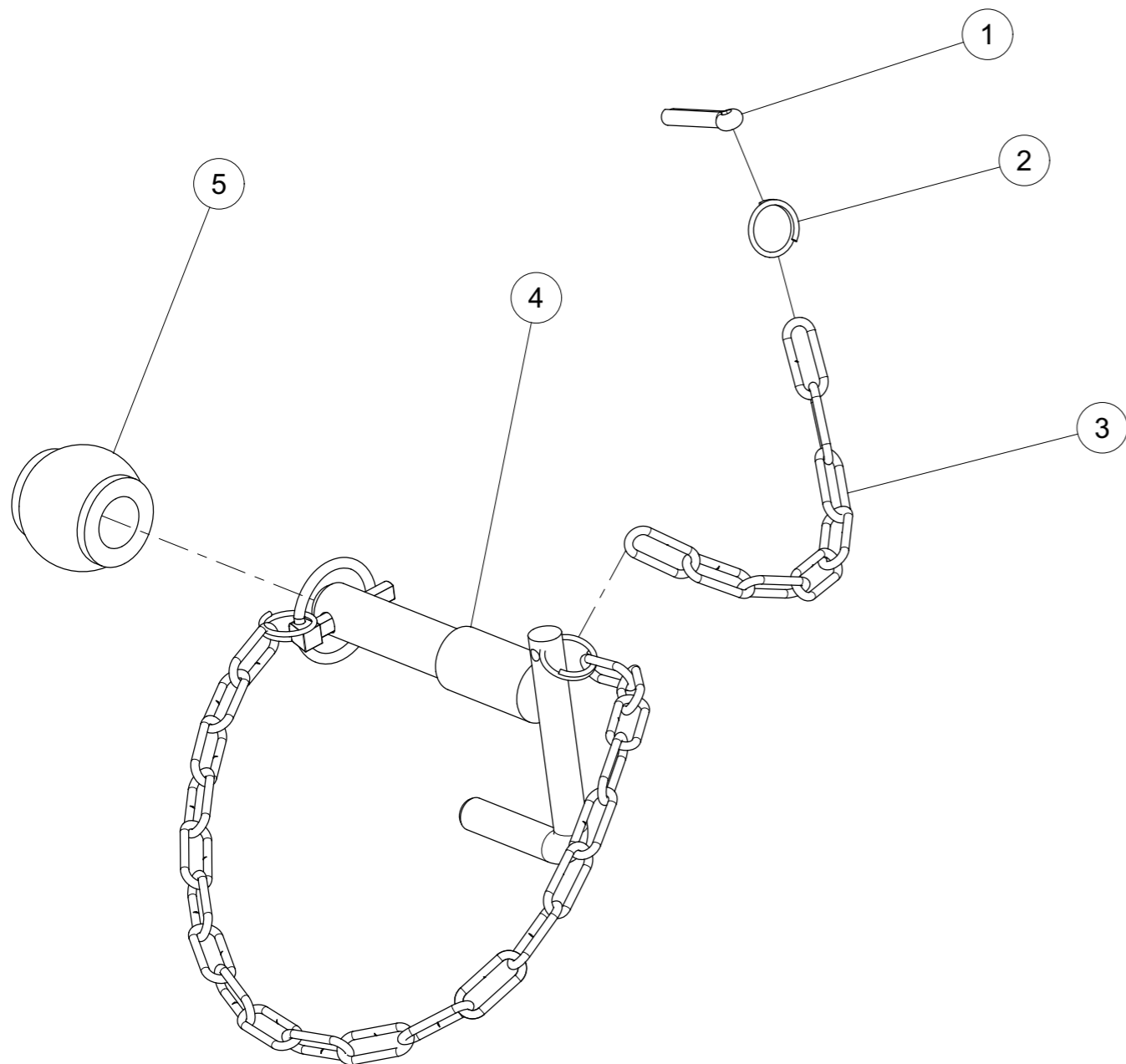

Kreismesser KG-30M/30ML

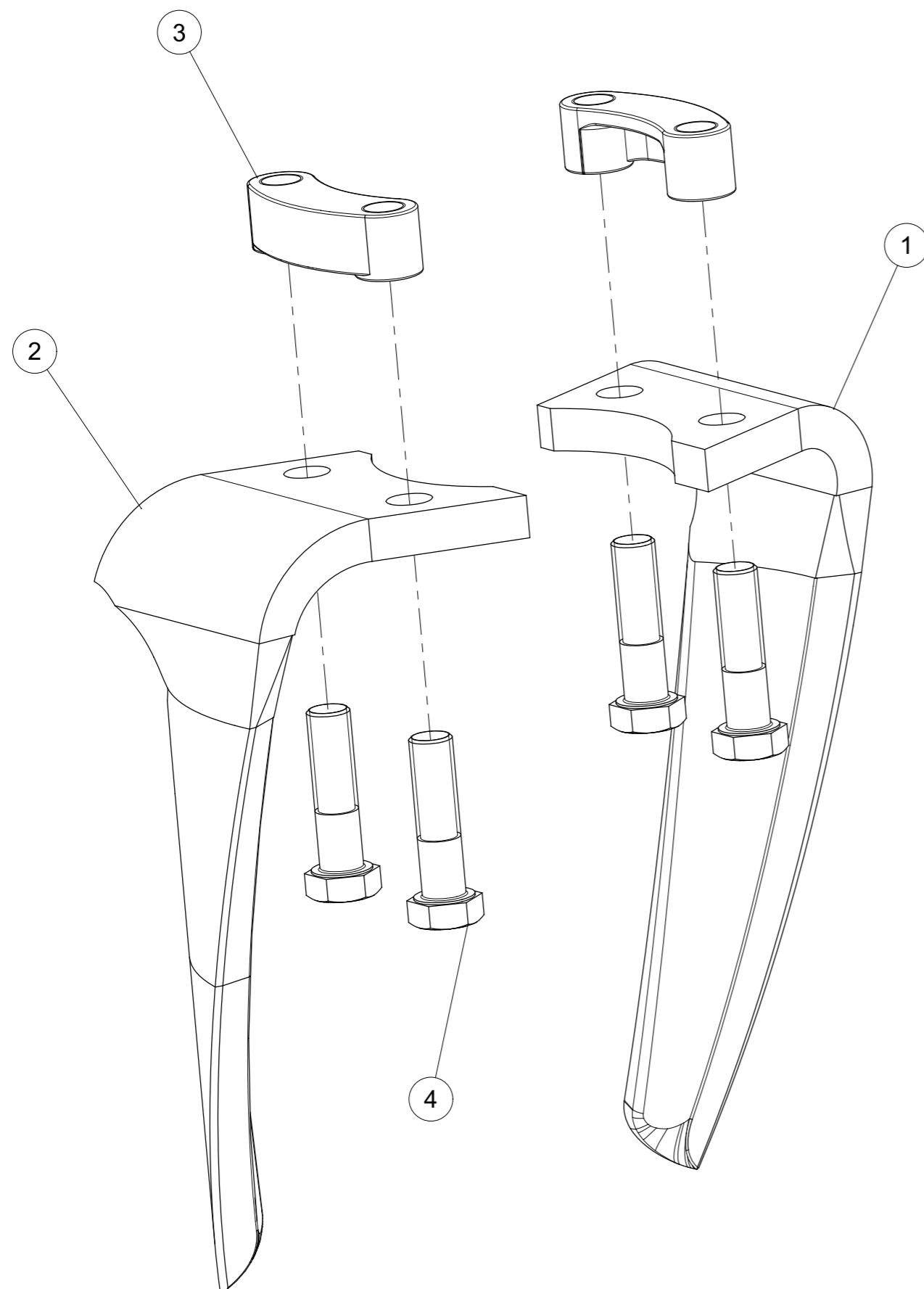

Pos. / Index	Stck. / Qty	Artikel-Nr.	Benennung / Designation
1	1	8404.50.07	Kreismesser Re. KG-30M
2	1	8404.50.08	Kreismesser Li. KG-30ML
3	2	8437.00.71	Schraubensicherung M16x1,5 verg.
4	4	960D161560M	Hex. Schraube M16x1.5x60 Blank Hex. Screw M16x1.5x60 Black Vis hex. M16x1.5x60 noire

Kreismesser RABID KG-30Z/30LZ

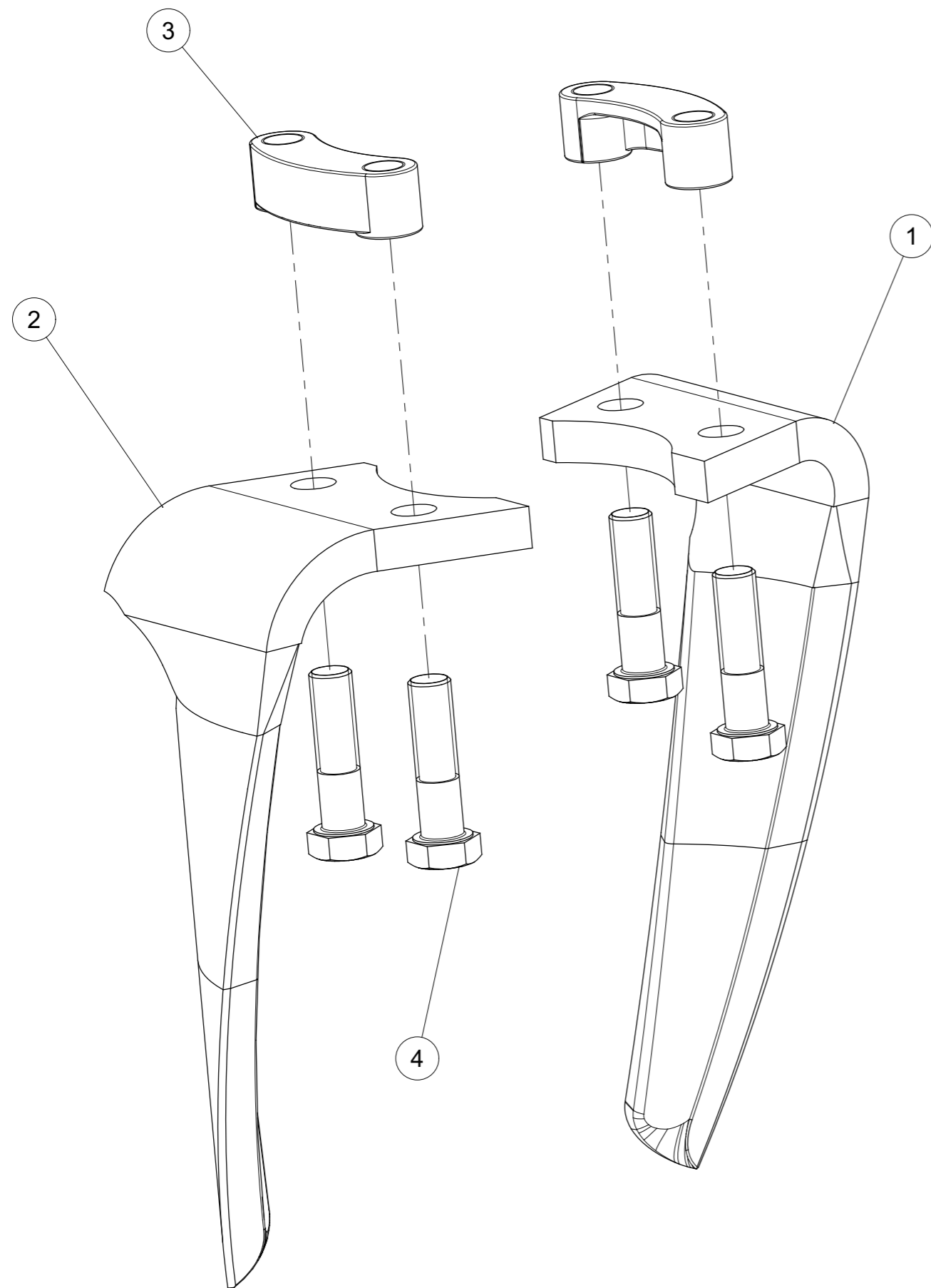

Pos. / Index	Stck. / Qty	Artikel-Nr.	Benennung / Designation
1	1	8411.62.03	Kreismesser Re. KG-30Z
2	1	8411.62.04	Kreismesser Li. KG-30LZ
3	2	8437.00.71	Schraubensicherung M16x1,5 verg.
4	4	960D161560M	Hex. Schraube M16x1.5x60 Blank Hex. Screw M16x1.5x60 Black Vis hex. M16x1.5x60 noire

Schnellwechselsystem Ausf. 2 kpl.

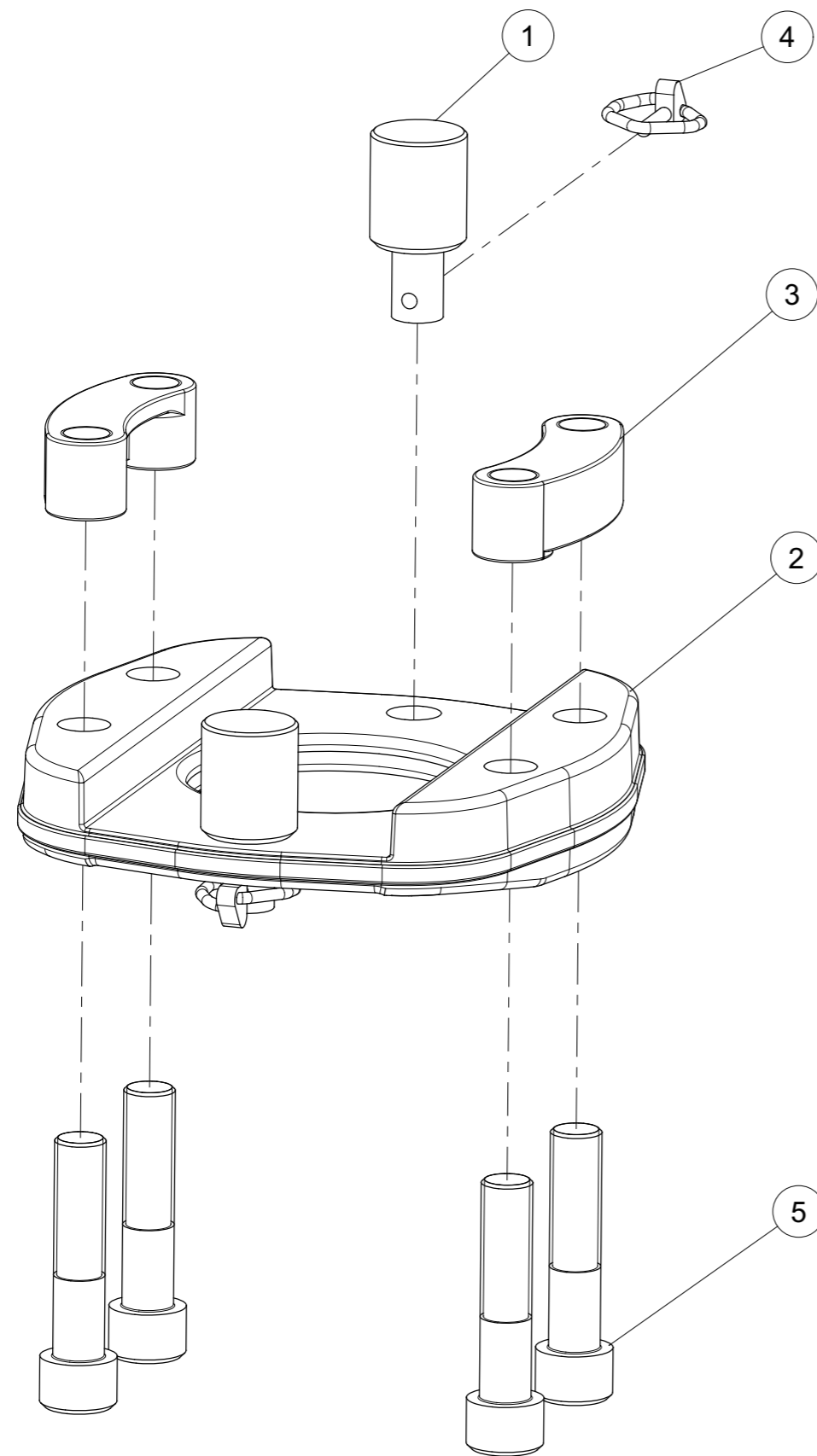

Pos. / Index	Stck. / Qty	Artikel-Nr.	Benennung / Designation
1	2	8437.75.02	Bolzen
2	1	8437.74.02	Grundplatte
3	2	8437.00.71	Schraubensicherung M16x1,5 verg.
4	2	8405.12.11	Sicherheitsklappstecker
5	4	912D161570M	Zylinderschr. m. Innensechskant

<i>Pos. / Index</i>	<i>Stck. / Qty</i>	<i>Artikel-Nr.</i>	<i>Benennung / Designation</i>
1	1	8437.75.01	Schnellwechselsystem Ausf. 2 kpl.
2	1	8437.77.01	Kreismesser rechts KG 34
3	1	8437.77.02	Kreismesser links KG 34 L

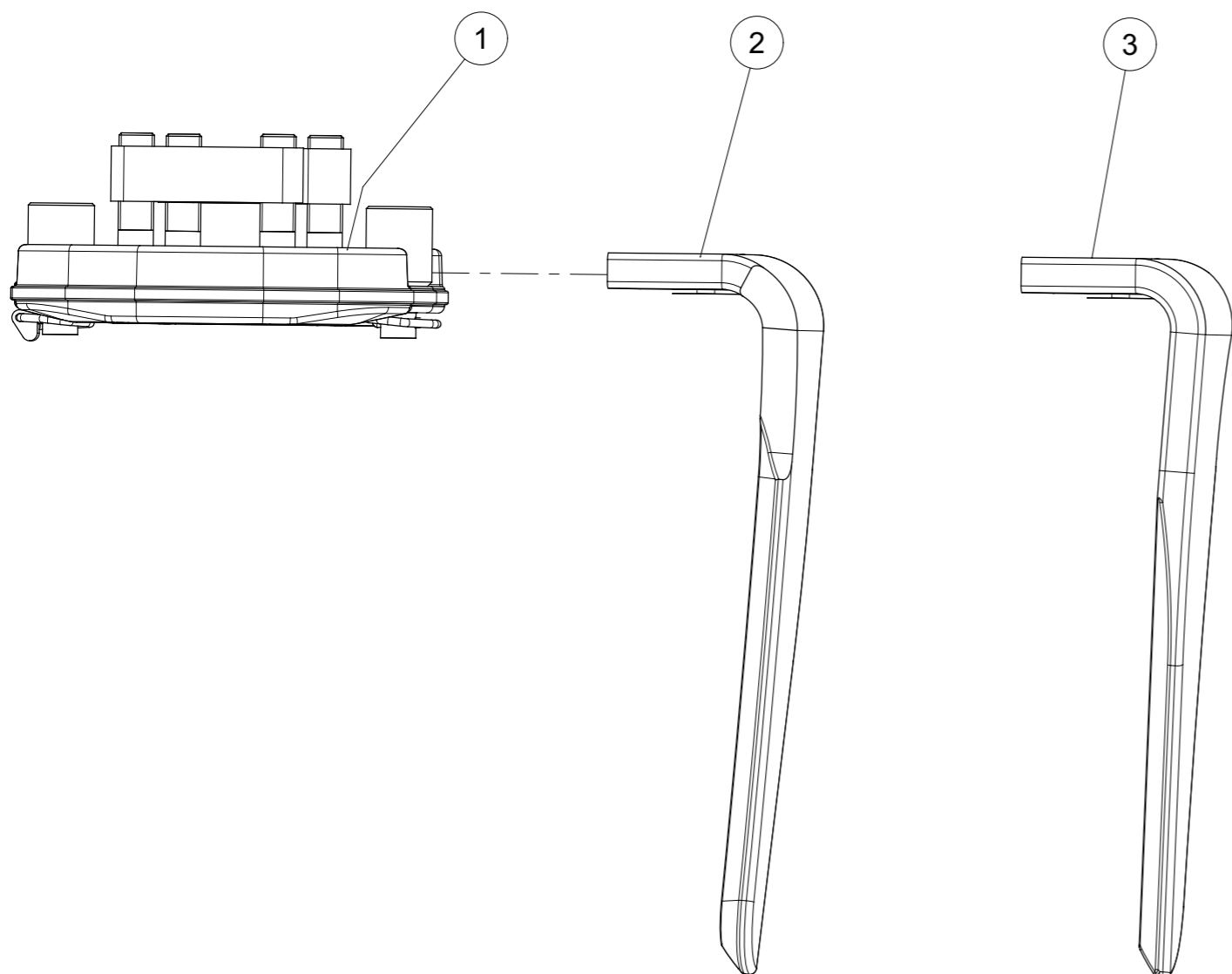

Multi-fix Schnellwechsel KG-34 Z Rabid

Pos. / Index	Stck. / Qty	Artikel-Nr.	Benennung / Designation
1	1	8411.62.15	Rabid-Kreismesser Rechts KG-34 Z
2	1	8411.62.16	Rabid Kreismesser Links KG-34 LZ
3	1	8437.75.01	Schnellwechselsystem Ausf. 2 kpl.

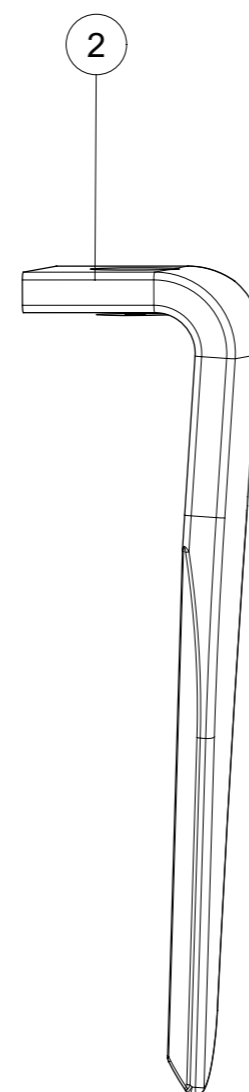
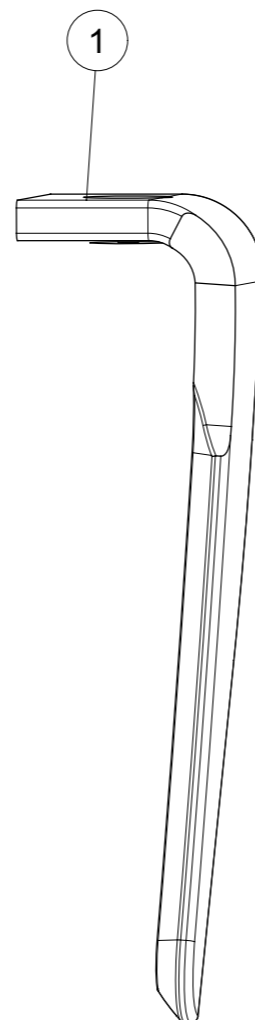
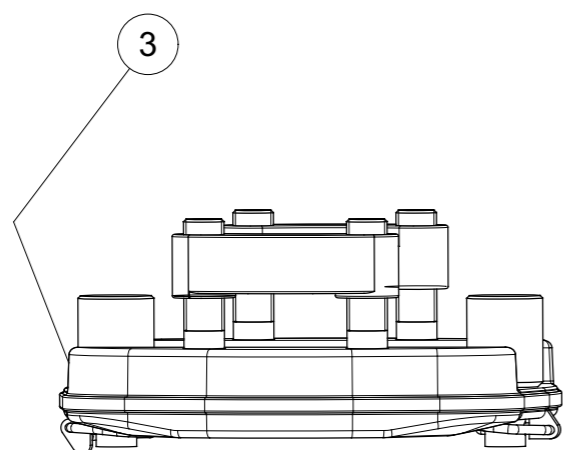

Segmentenschutzschiene vorn 3.0m kpl.

Pos. / Index	Stck. / Qty	Artikel-Nr.	Benennung / Designation
1	1	8435.50.11	Segmentenschutzschiene gs. 3.0m li.
2	1	8435.50.12	Segmentenschutzschiene gs. 3.0m re.

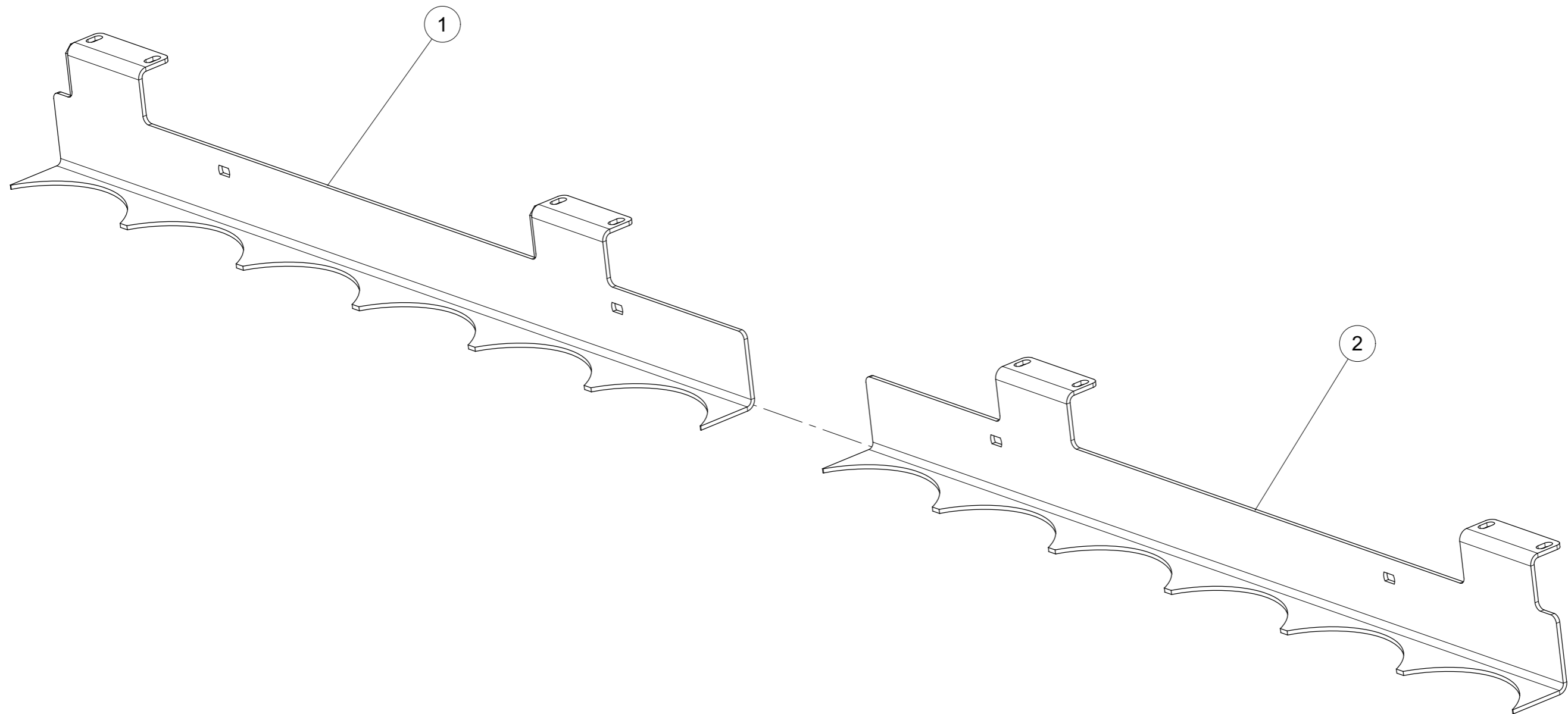

Lager- und Messerhalterschutz 3.0m



<i>Pos. / Index</i>	<i>Stck. / Qty</i>	<i>Artikel-Nr.</i>	<i>Benennung / Designation</i>
1	1	8438.03.02	Lager und Messerhalterschutz 3.0m

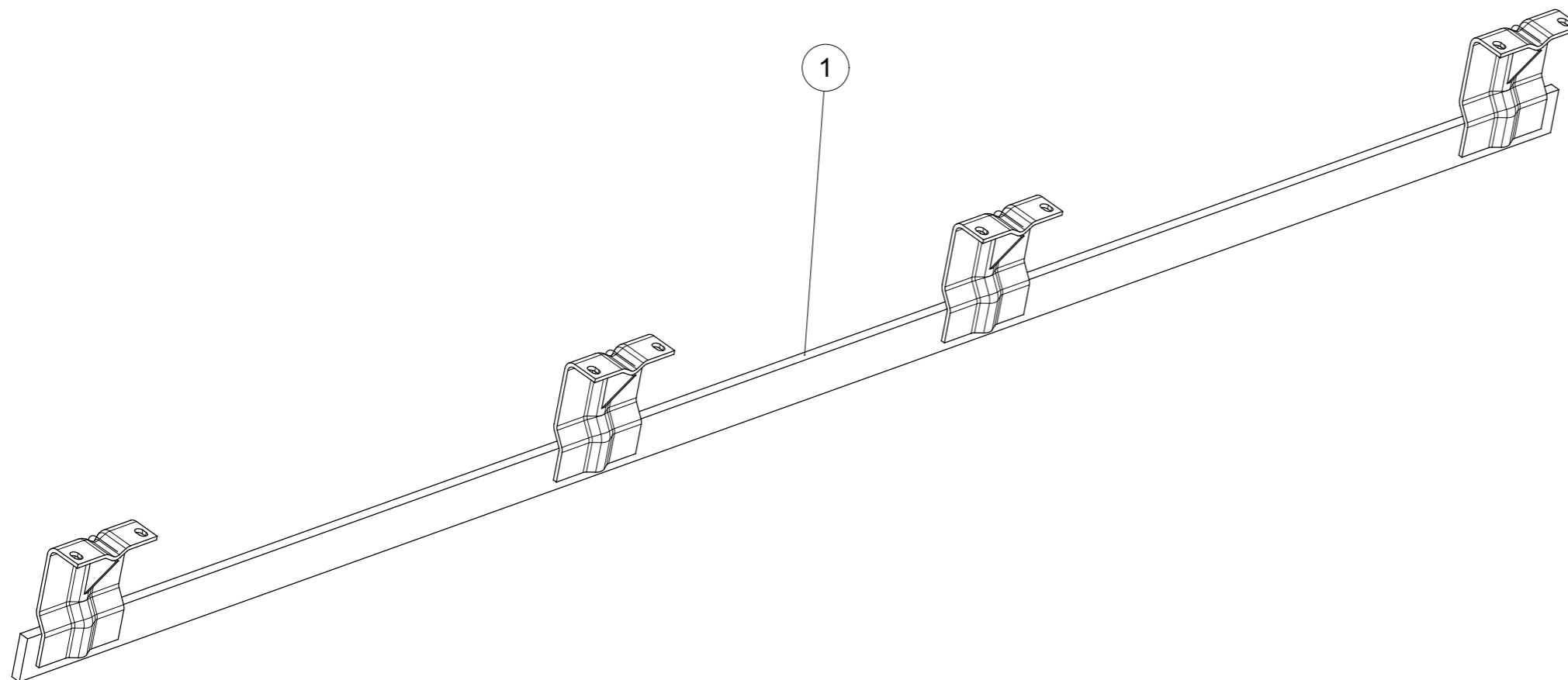

8438.03.02 (2/2)

Getriebe PKE 3011, PKE 4011

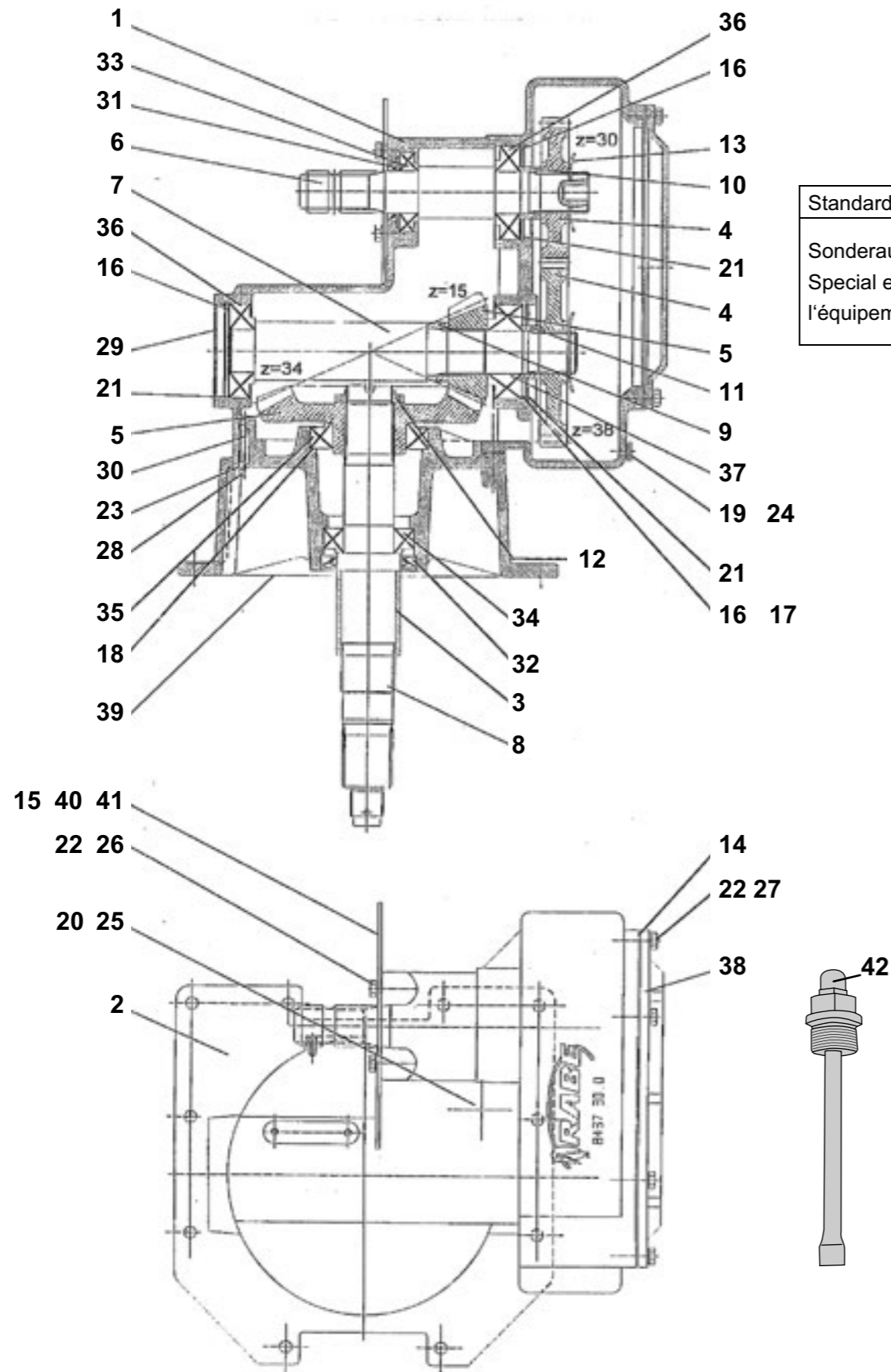

Standard
 Sonderausstattung
 Special equipment
 l'équipement spécial

Pos.	Anz.	Artnr.	Benennung	designation (fra)	Designation (eng)
1	1	8437.70.11	Gehäuse	Carter	Housing
2	1	8444.03.13	Lagergehäuse	Braquette	Bearing housing
3	1	8437.90.11	Distanzbuchse	Bague entretoise	Spacer
4	1	8437.73.03	Wechselradsatz Z 30/38	Jeu de pignon interchange.	Change gear kit
4	1	8437.73.01	Wechselradsatz Z 25/43	Jeu de pignon interchange.	Change gear kit
4	1	8437.73.02	Wechselradsatz Z 27/41	Jeu de pignon interchange.	Change gear kit
4	1	8437.73.04	Wechselradsatz Z 32/36	Jeu de pignon interchange.	Change gear kit
4	1	8437.73.05	Wechselradsatz Z 33/35	Jeu de pignon interchange.	Change gear kit
5	1	8437.70.35	Kegeltrieb kpl. Z 15/34, 3,0 m+4,0 m	Paire de pignons coniques	Bevel gear set
6	1	8437.70.17	Antriebswelle	Arbre d'entree	Input shaft
7	1	8437.70.18	Ritzelwelle 3,0 m + 4,0 m	Arbre intermediaire	Pinion shaft
8	1	8437.90.10	Getriebewelle	Arbre	Shaft
9	1	8437.70.23	Buchse 3,0 m + 4,0 m	Douille	Bush
10	1	8437.70.24	Buchse	Douille	Bush
11	1	8437.70.25	Buchse 3,0 m + 4,0 m	Douille	Bush
12	1	8437.70.20	Nutmutter M50x1,5	Ecrou à garges	Key nut
13	2	8437.70.21	Feder	Ressort	Spring
14	1	8437.70.22	Deckeldichtung	Joint de couvercle	Packing
15	1	8437.70.26	Blech	Tôle	Plate
16	1	8404.46.06	Satz Passscheiben E1 90x100 kpl.	Set cale d'adjustage	Set gauge washer
17	1	988DS85100	Stützscheibe S 85x100 DIN988	Rondelle pour bague	Supporting washer
18	1	8404.46.10	Satz Passscheiben E1 110x130 kpl.	Set cale d'adjustage	Set gauge washer
19	1	7603DA162215CU	Dichtring A 16x22x1,5 DIN7603-CU	Joint	Seal ring
20	1	7603DA26322CU	Dichtring A 26x32x2 DIN7603-CU	Joint	Seal ring
21	3	472D1003	Sicherungsring 100x3 DIN472	Circlip	Circlip
22	13	127DA8A	Federring A8 DIN127 vz.	Rondelle grower	Springwasher

8437.90.01

Getriebe PKE 3011, PKE 4011

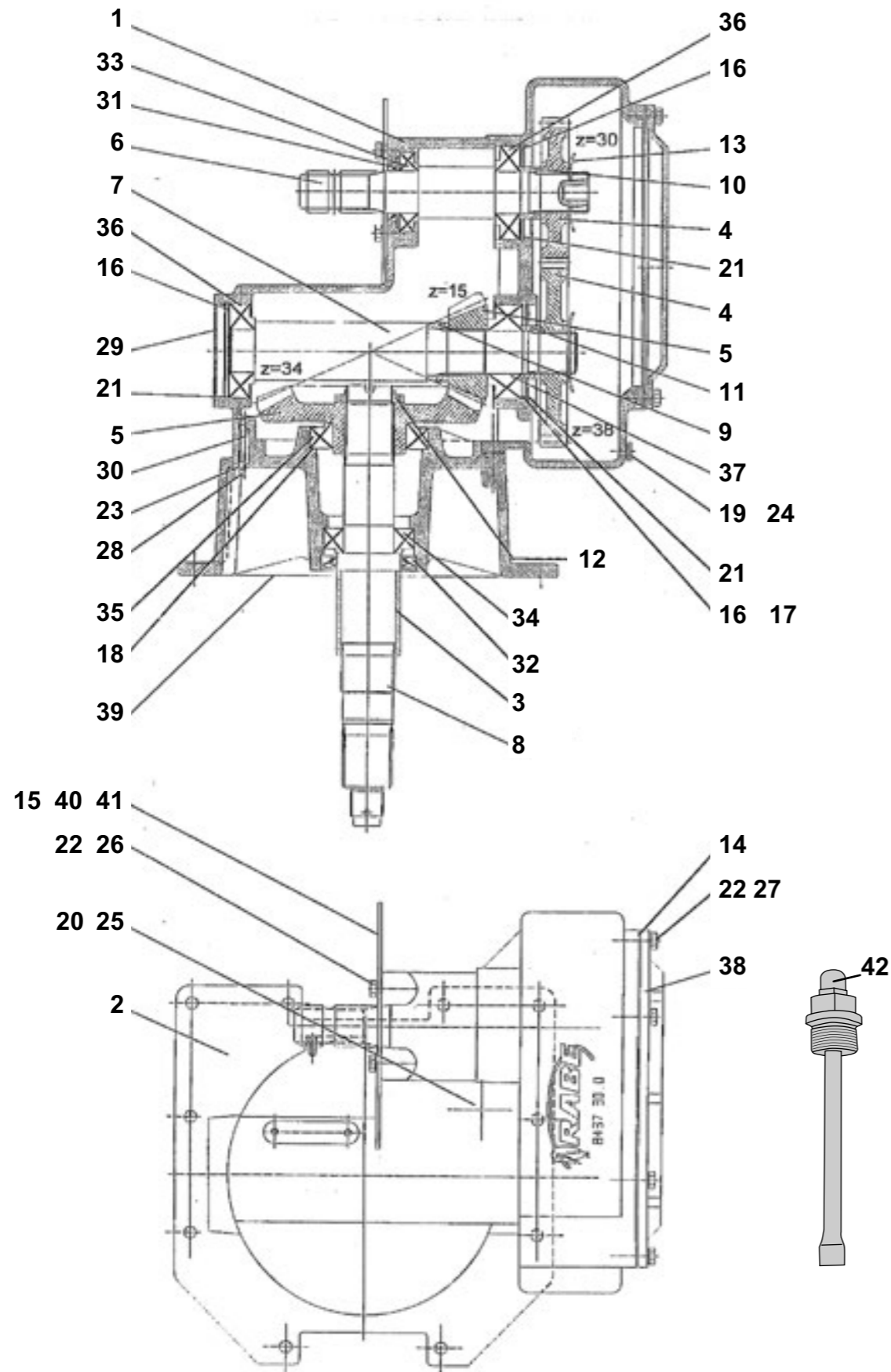

Pos.	Anz.	Artnr.	Benennung	designation (fra)	Designation (eng)
23	8	WAL596279	Scheibe A 12 Form M verzinkt	Rondelle	Washer
24	1	908D1615V	Verschlußschraube M16x1,5 DIN908-5.8	Bouchon fileté	Hexagon head plug
25	1	908D2615V	Verschlußschraube M26x1,5 DIN908-5.8	Bouchon fileté	Hexagon head plug
26	2	933D816PA	Sechskantschraube M8x16 DIN933-8.8	Vis 6 pans	Hex. bolt
27	11	933D825PA	Sechskantschraube M8x25 DIN933-8.8	Vis 6 pans	Hex. bolt
28	8	933D1240NA	Sechskantschraube M12x40 DIN933-10.9	Vis 6 pans	Hex. bolt
29	1	WAL593767	Verschlußkappe	Couvercle de fermé	End lid
30	2	6325D10M636	Zylinderstift 10m6 x36 DIN6325	Goupille fendue	Cylindrical dovel
31	1	3760D456210BA	Wellendichtring 45x62x10 BA DIN3760	Joint de arbre	Shaft sealing ring
32	1	8409.01.10	Wellendichtring 70x105x13 B2 DIN3760	Joint de arbre	Shaft sealing ring
33	1	720D30209	Kegelrollenlager 30209 DIN720	Roulement à rouleaux	Taper roller bearing
34	1	720D30211	Kegelrollenlager 30211 DIN720	Roulement à rouleaux	Taper roller bearing
35	1	720D30215	Kegelrollenlager 30215 DIN720	Roulement à rouleaux	Taper roller bearing
36	2	720D30309	Kegelrollenlager 30309 DIN720	Roulement à rouleaux	Taper roller bearing
37	1	720D32309	Kegelrollenlager 32309 DIN720	Roulement à rouleaux	Taper roller bearing
38	1	8437.70.13	Deckel	Couvercle	Lid
39	1	8437.00.30	Getriebedichtung	Joint de boîte de vitesse	Gasket
40	1	8437.72.99	Schutz kpl.	Protection cpl.	Cover cpl.
41	2	933D820PA	Sechskantschraube M8x20 DIN933-8.8 vz.	Vis 6 pans	Hex. bolt
42	1	8444.07.10	Ölmeßstab	Jauge d'huile	Dipstick
4,5		GETRIEBEOEL	Getriebeöl Hypoid GL 5 SAE 90	Huile	Gear oil

8437.90.01

Wechselradgetriebe mit Durchtrieb - 1 3/8" / Gearbox with PTO through drive - 1 3/8" /
 Boltier de vitesse avec prise de force arr. - 1 3/8"

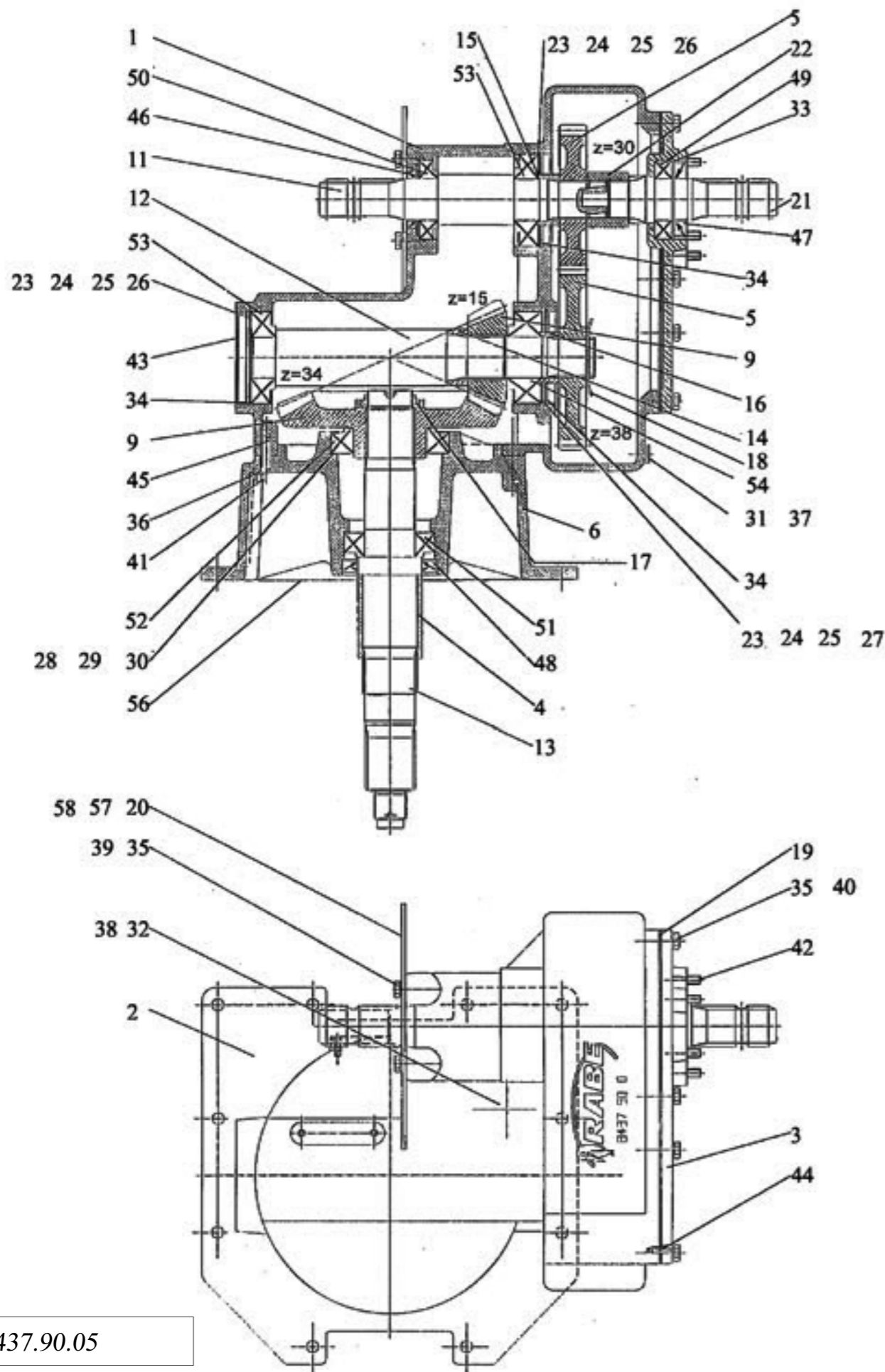

Pos. / Index	Stck. / Qty.	Artikel-Nr.	Benennung / Designation
1	1	8437.70.11	Gehäuse Housing Carter
2	1	8437.70.12	Lagergehäuse Bearing housing Braquette
3	1	8437.70.42	Deckel f. Durchtrieb Cover Couvercle
4	1	8437.90.11	Distanzbuchse Spacer Bague entretoise
5	1	8437.73.03	Wechselradsatz z 30/38 Change gear kit Jeu de pignon interchange.
5	1	8437.73.01	Wechselradsatz z 25/43 Change gear kit Jeu de pignon interchange.
5	1	8437.73.02	Wechselradsatz z 27/41 Change gear kit Jeu de pignon interchange.
5	1	8437.73.04	Wechselradsatz z 32/36 Change gear kit Jeu de pignon interchange.
5	1	8437.73.05	Wechselradsatz z 33/35 Change gear kit Jeu de pignon interchange.
6	1	8437.90.13	Gehäusesockel Base Base
9	1	8437.70.35	Kegeltrieb kpl. z 15/34, 3,0 m+4,0 m Bevel gear set Paire de pignons coniques
9	1	8437.70.36	Kegeltrieb kpl. z 15/34, 2,5 m+4,5 m Bevel gear set Paire de pignons coniques
11	1	8437.70.17	Antriebswelle Input shaft Arbre d'entree
12	1	8437.70.18	Ritzelwelle Pinion shaft Arbre intermediaire
13	1	8437.90.10	Getriebewelle Shaft Arbre
14	1	8437.70.23	Buchse Bush Douille

Wechselradgetriebe mit Durchtrieb - 1 3/8" / Gearbox with PTO through drive - 1 3/8" /
 Boltier de vitesse avec prise de force arr. - 1 3/8"

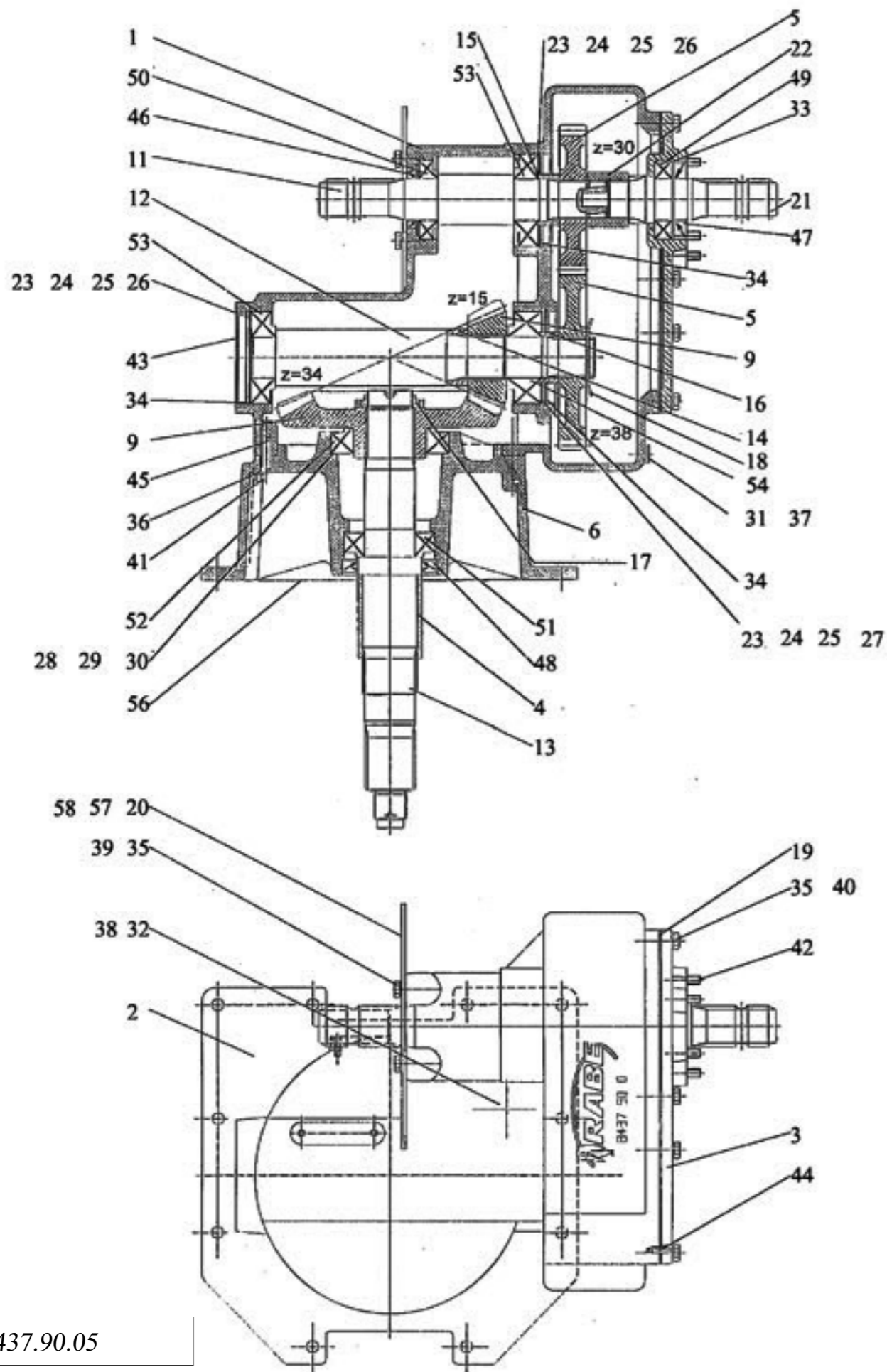

Pos. / Index	Stck. / Qty.	Artikel-Nr.	Benennung / Designation
15	1	8437.70.24	Buchse Bush Douille
16	1	8437.70.25	Buchse Bush Douille
17	1	8437.70.20	Nutmutter M50x1,5 Key nut Ecrou a gorges
18	2	8437.70.21	Feder Spring Ressort
19	1	8437.70.22	Deckeldichtung Gasket Joint de couvercle
20	1	8437.70.26	Blech Plate Tôle
21	1	8437.70.40	Durchtriebswelle 1 3/8" Input shaft Arbre d'entree
22	1	8437.70.44	Buchse Bush Douille
23	2	9880851001	Paßscheibe 85x100x1 DIN988 Gauge washer Cale d'ajustage
24	6	9880851000.1	Paßscheibe 85x100x0,1 DIN988 Gauge washer Cale d'ajustage
25	6	9880851000.2	Paßscheibe 85x100x0,2 DIN988 Gauge washer Cale d'ajustage
26	4	9880851000.3	Paßscheibe 85x100x0,3 DIN988 Gauge washer Cale d'ajustage
27	1	988DS85100	Stützscheibe S 85x100 DIN988 Supporting washer Rondelle pour bague
28	2	988D1101300.1	Paßscheibe 110x130x0,1 DIN988 Gauge washer Cale d'ajustage
29	2	988D1101300.2	Paßscheibe 110x130x0,2 DIN988 Gauge washer Cale d'ajustage

8437.90.05

06-Feb-14

Revision :
M a J :

Wechselradgetriebe mit Durchtrieb - 1 3/8" / Gearbox with PTO through drive - 1 3/8" /
 Boltier de vitesse avec prise de force arr. - 1 3/8"

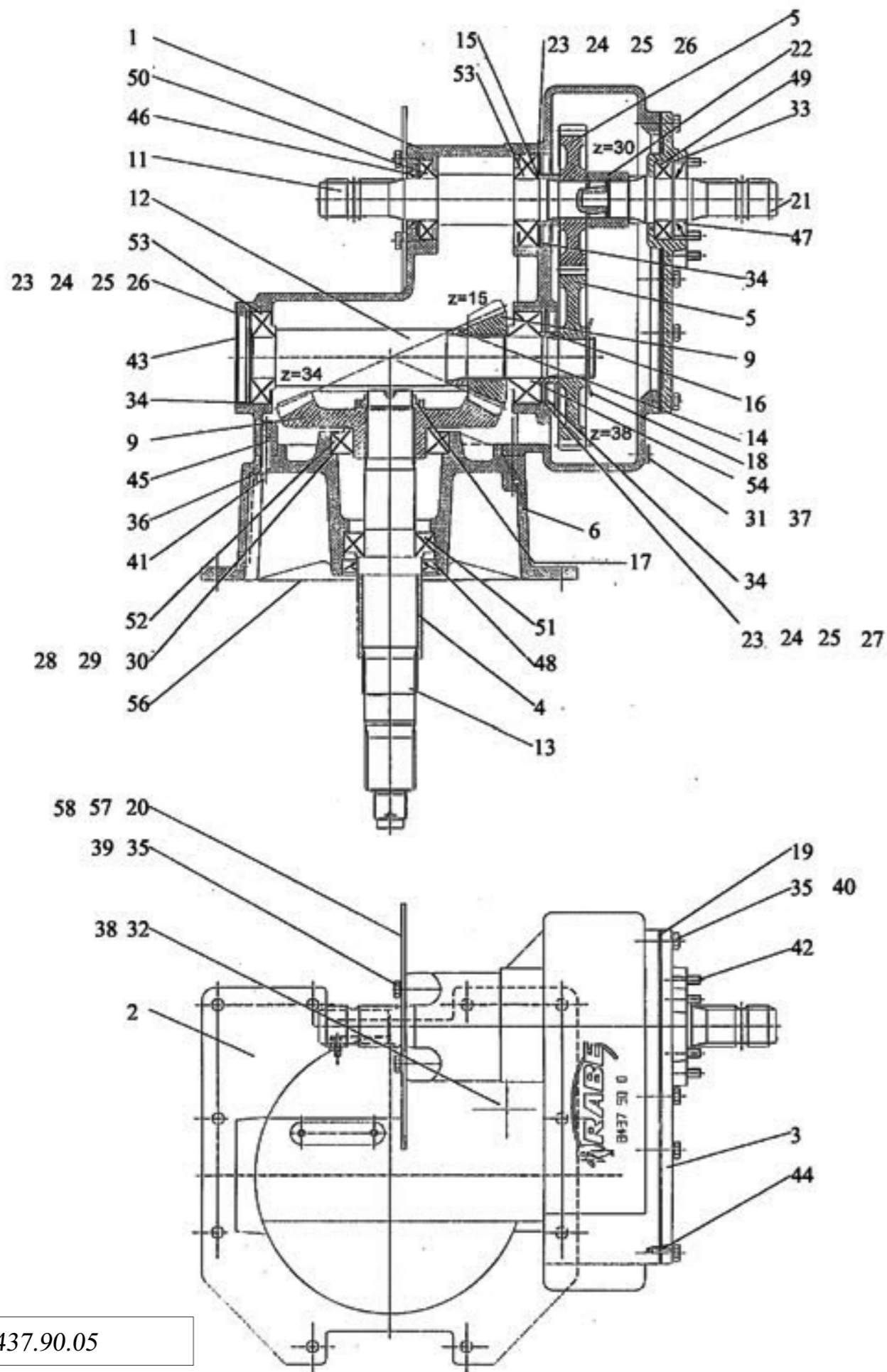

Pos. / Index	Stck. / Qty.	Artikel-Nr.	Benennung / Designation
30	2	988D1101300.3	Paßscheibe 110x130x0,3 DIN988 Gauge washer Cale d'ajustage
31	1	7603D162215CU	Dichtring A 16x22x1,5 DIN7603-CU Seal ring Joint
32	1	7603DA26322CU	Dichtring A 26x32x2 DIN7603-CU Seal ring J oint
33	1	472D853	Sicherungsring 85x3 DIN472 Circlip Circlip
34	3	472D1003	Sicherungsring 100x3 DIN472 Circlip Circlip
35	13	127DA8A	Federring A8 DIN127 vz. Springwasher Rondelle grower
36	8	WAL596279	Scheibe A 12 Form M verzinkt Washer Rondelle
37	1	908D1615V	Verschlußschraube M16x1,5 DIN908-5.8 Hexagon head plug Bouchon filete
38	1	908D2615V	Verschlußschraube M26x1,5 DIN908-5.8 Hexagon head plug Bouchon filete
39	2	933D816P	Sechskantschraube M8x16 DIN933-8.8 Hex. bolt Vis 6 pans
40	11	933D825P	Sechskantschraube M8x25 DIN933-8.8 Hex. bolt Vis 6 pans
41	8	933D1240N	Sechskantschraube M12x40 DIN933-10.9 Hex. bolt Vis 6 pans
42	4	913D1030N	Gewindestift M10x30 DIN913-10.9 Threaded pin Vis sans fete
43	1	WAL593767	Verschlußkappe End lid Couvercle de ferme
44	2	6325D8M628	Zylinderstift 8m6 x28 DIN6325 Cylindrical dovel Goupille fendue
45	2	6325D10M636	Zylinderstift 10m6 x36 DIN6325 Cylindrical dovel Goupille fendue

Wechselradgetriebe mit Durchtrieb - 1 3/8" / Gearbox with PTO through drive - 1 3/8" /
 Boltier de vitesse avec prise de force arr. - 1 3/8"

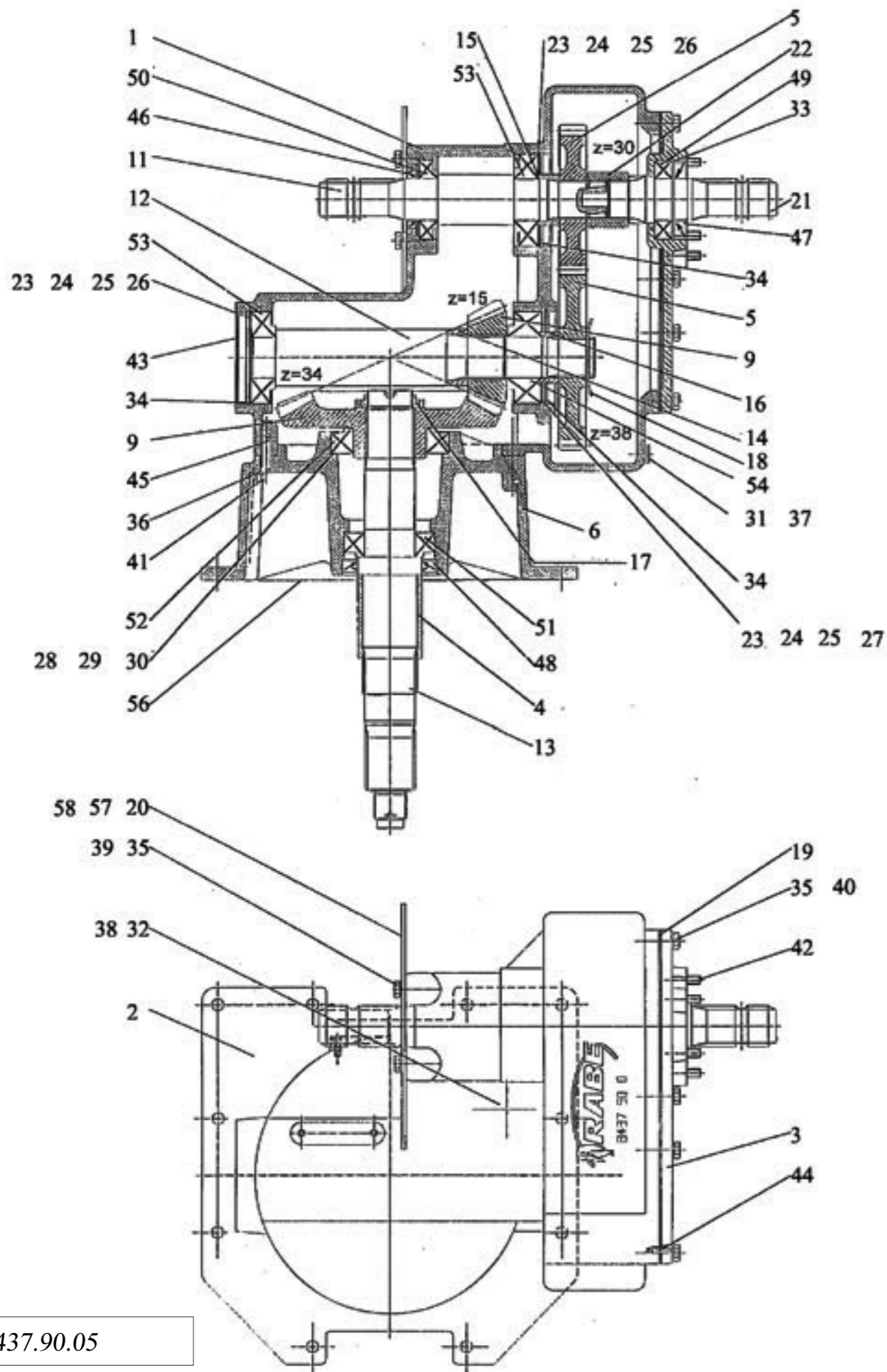

Pos. / Index	Stck. / Qty.	Artikel-Nr.	Benennung / Designation
46	1	3760D456210BA	Wellendichtring 45x62x10 BA DIN3760 Shaft sealing ring Joint de arbre
47	1	3760D458513B2	Wellendichtring 45x85x13 B2 DIN3760 Shaft sealing ring Joint de arbre
48	1	3760D7010513B2	Wellendichtring 70x105x13 B2 DIN3760 Shaft sealing ring Joint de arbre
49	1	625D6209	Rillenkugellager 6209 DIN625 Ball bearing Roulement a billes
50	1	720D30209	Kegelrollenlager 30209 DIN720 Taper roller bearing Roulement a rouleaux
51	1	720D30211	Kegelrollenlager 30211 DIN720 Taper roller bearing Roulement a rouleaux
52	1	720D30215	Kegelrollenlager 30215 DIN720 Taper roller bearing Roulement a rouleaux
53	2	720D30309	Kegelrollenlager 30309 DIN720 T aper roller bearing Roulement a rouleaux
54	1	720D32309	Kegelrollenlager 32309 DIN720 Taper roller bearing Roulement a rouleaux
55	1	8437.70.13	Deckel Lid Couvercle
56	1	8437.00.30	Getriebedichtung Gasket Joint de boite de vitesse
57	1	8437.72.99	Schutz kpl. Cover cpl. Protection cpl.
58	2	933D820PA	Sechskantschraube M8x20 DIN933-8.8 vz. Hex. bolt Vis 6 pans
	4,5	GETRIEBEOEL/5	Getriebeöl Hypoid GL 5 SAE 90 Gear oil Huile

8437.90.05

06-Feb-14

Revision :
M a J :

Wechselradgetriebe mit Durchtrieb - 1 $\frac{3}{4}$ " / Gearbox with PTO through drive - 1 $\frac{3}{4}$ " /
 Boltier de vitesse avec prise de force arr. - 1 $\frac{3}{4}$ "

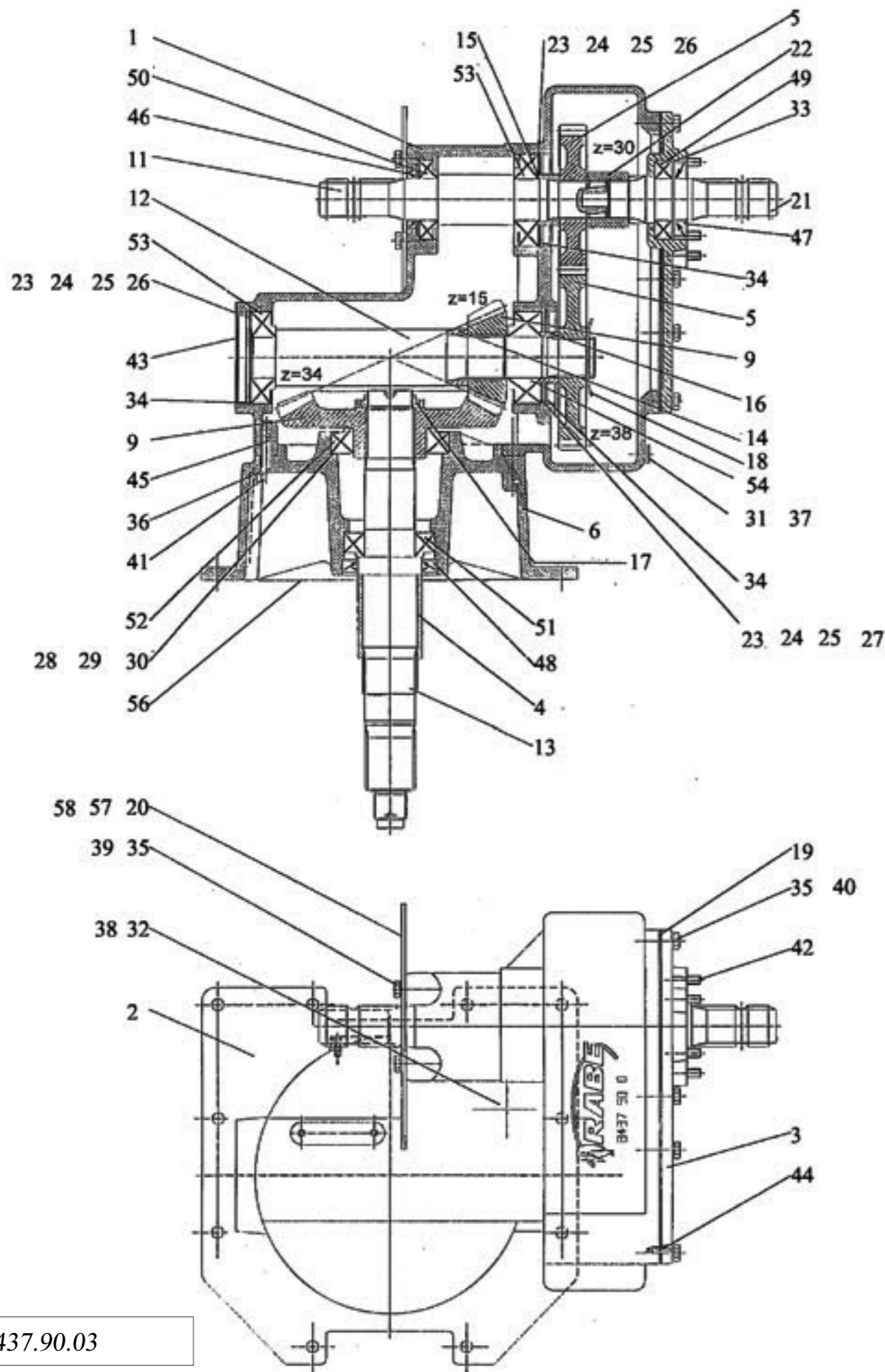

Pos. / Index	Stck. / Qty.	Artikel-Nr.	Benennung / Designation
1	1	8437.70.11	Gehäuse Housing Carter
2	1	8437.70.12	Lagergehäuse Bearing housing Braquette
3	1	8437.70.42	Deckel f. Durchtrieb Cover Couvercle
4	1	8437.90.11	Distanzbuchse Spacer Bague entretoise
5	1	8437.73.03	Wechselradsatz z 30/38 Change gear kit Jeu de pignon interchange.
5	1	8437.73.01	Wechselradsatz z 25/43 Change gear kit Jeu de pignon interchange.
5	1	8437.73.02	Wechselradsatz z 27/41 Change gear kit Jeu de pignon interchange.
5	1	8437.73.04	Wechselradsatz z 32/36 Change gear kit Jeu de pignon interchange.
5	1	8437.73.05	Wechselradsatz z 33/35 Change gear kit Jeu de pignon interchange.
6	1	8437.90.13	Gehäusesockel Base Base
9	1	8437.70.35	Kegeltrieb kpl. z 15/34, 3,0 m+4,0 m Bevel gear set Paire de pignons coniques
9	1	8437.70.36	Kegeltrieb kpl. z 15/34, 2,5 m+4,5 m Bevel gear set Paire de pignons coniques
11	1	8437.70.17	Antriebswelle Input shaft Arbre d'entree
12	1	8437.70.18	Ritzelwelle Pinion shaft Arbre intermediaire
13	1	8437.90.10	Getriebewelle Shaft Arbre
14	1	8437.70.23	Buchse Bush Douille

Wechselradgetriebe mit Durchtrieb - 1 3/4" / Gearbox with PTO through drive - 1 3/4" /
 Boltier de vitesse avec prise de force arr. - 1 3/4"

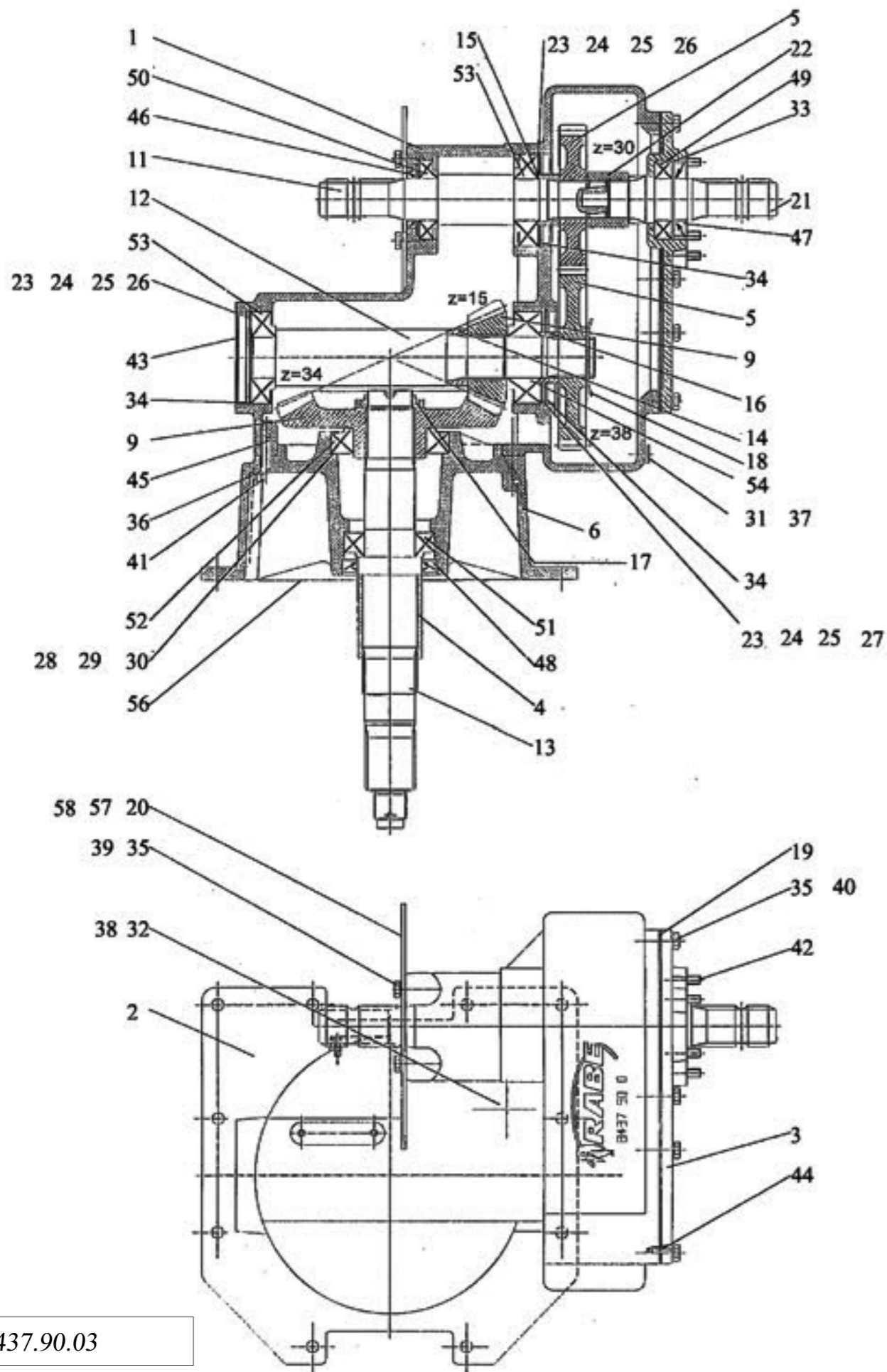

Pos. / Index	Stck. / Qty.	Artikel-Nr.	Benennung / Designation
15	1	8437.70.24	Buchse Bush Douille
16	1	8437.70.25	Buchse Bush Douille
17	1	8437.70.20	Nutmutter M50x1,5 Key nut Ecrou a gorges
18	2	8437.70.21	Feder Spring Ressort
19	1	8437.70.22	Deckeldichtung Gasket Joint de couvercle
20	1	8437.70.26	Blech Plate Tôle
21	1	8437.70.41	Durchtriebswelle 1 3/4" Input shaft Arbre d'entree
22	1	8437.70.44	Buchse Bush Douille
23	2	9880851001	Paßscheibe 85x100x1 DIN988 Gauge washer Cale d'ajustage
24	6	9880851000.1	Paßscheibe 85x100x0,1 DIN988 Gauge washer Cale d'ajustage
25	6	9880851000.2	Paßscheibe 85x100x0,2 DIN988 Gauge washer Cale d'ajustage
26	4	9880851000.3	Paßscheibe 85x100x0,3 DIN988 Gauge washer Cale d'ajustage
27	1	988DS85100	Stützscheibe S 85x100 DIN988 Supporting washer Rondelle pour bague
28	2	988D1101300.1	Paßscheibe 110x130x0,1 DIN988 Gauge washer Cale d'ajustage
29	2	988D1101300.2	Paßscheibe 110x130x0,2 DIN988 Gauge washer Cale d'ajustage

Wechselradgetriebe mit Durchtrieb - 1 3/4" / Gearbox with PTO through drive - 1 3/4" /
 Boltier de vitesse avec prise de force arr. - 1 3/4"

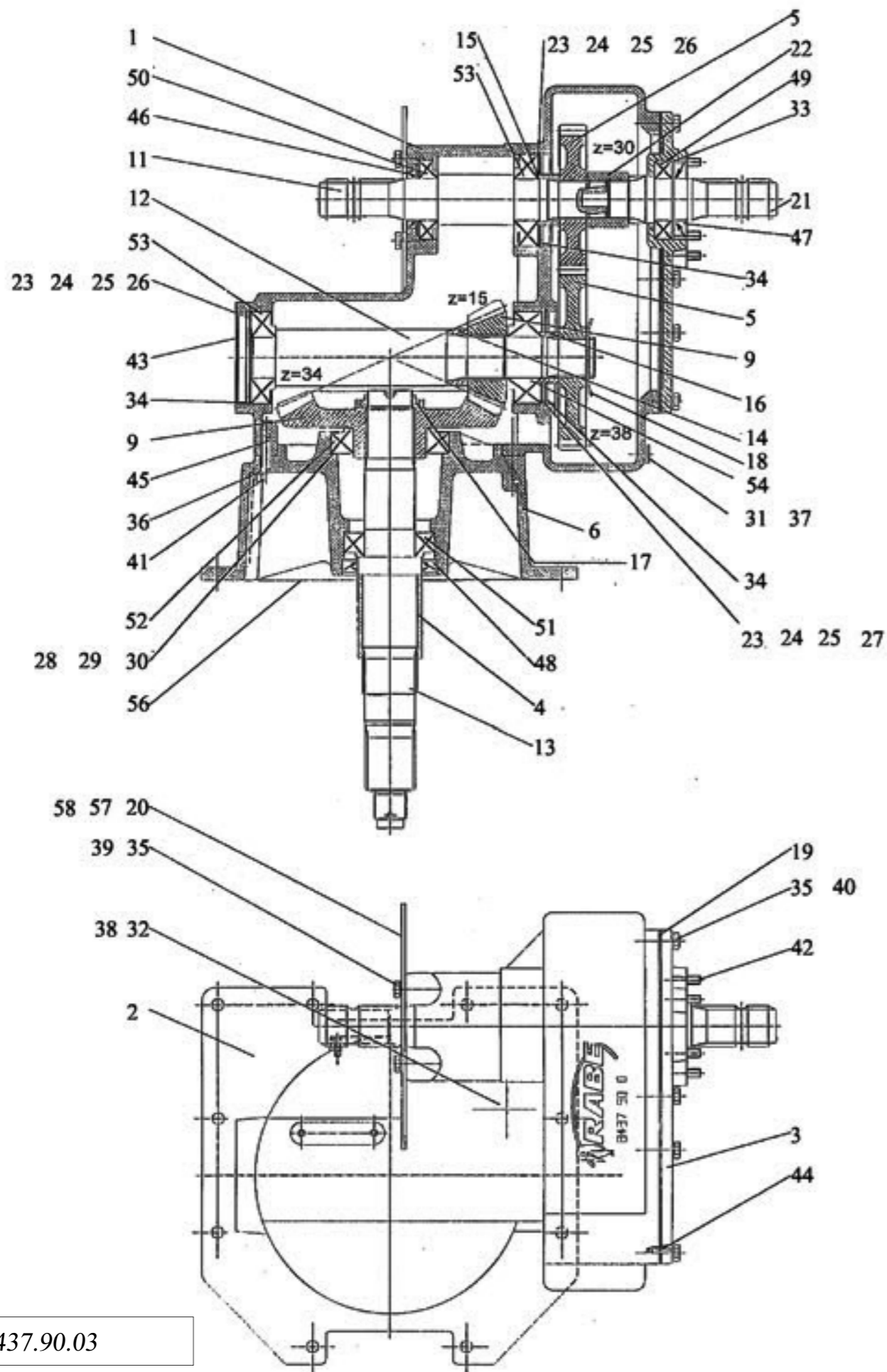

Pos. / Index	Stck. / Qty.	Artikel-Nr.	Benennung / Designation
30	2	988D1101300.3	Paßscheibe 110x130x0,3 DIN988 Gauge washer Cale d'ajustage
31	1	7603D162215CU	Dichtring A 16x22x1,5 DIN7603-CU Seal ring Joint
32	1	7603DA26322CU	Dichtring A 26x32x2 DIN7603-CU Seal ring J oint
33	1	472D853	Sicherungsring 85x3 DIN472 Circlip Circlip
34	3	472D1003	Sicherungsring 100x3 DIN472 Circlip Circlip
35	13	127DA8A	Federring A8 DIN127 vz. Springwasher Rondelle grower
36	8	WAL596279	Scheibe A 12 Form M verzinkt Washer Rondelle
37	1	908D1615V	Verschlußschraube M16x1,5 DIN908-5.8 Hexagon head plug Bouchon filete
38	1	908D2615V	Verschlußschraube M26x1,5 DIN908-5.8 Hexagon head plug Bouchon filete
39	2	933D816P	Sechskantschraube M8x16 DIN933-8.8 Hex. bolt Vis 6 pans
40	11	933D825P	Sechskantschraube M8x25 DIN933-8.8 Hex. bolt Vis 6 pans
41	8	933D1240N	Sechskantschraube M12x40 DIN933-10.9 Hex. bolt Vis 6 pans
42	4	913D1030N	Gewindestift M10x30 DIN913-10.9 Threaded pin Vis sans fete
43	1	WAL593767	Verschlußkappe End lid Couvercle de ferme
44	2	6325D8M628	Zylinderstift 8m6 x28 DIN6325 Cylindrical dovel Goupille fendue
45	2	6325D10M636	Zylinderstift 10m6 x36 DIN6325 Cylindrical dovel Goupille fendue

Wechselradgetriebe mit Durchtrieb - 1 3/4" / Gearbox with PTO through drive - 1 3/4" /
 Boltier de vitesse avec prise de force arr. - 1 3/4"

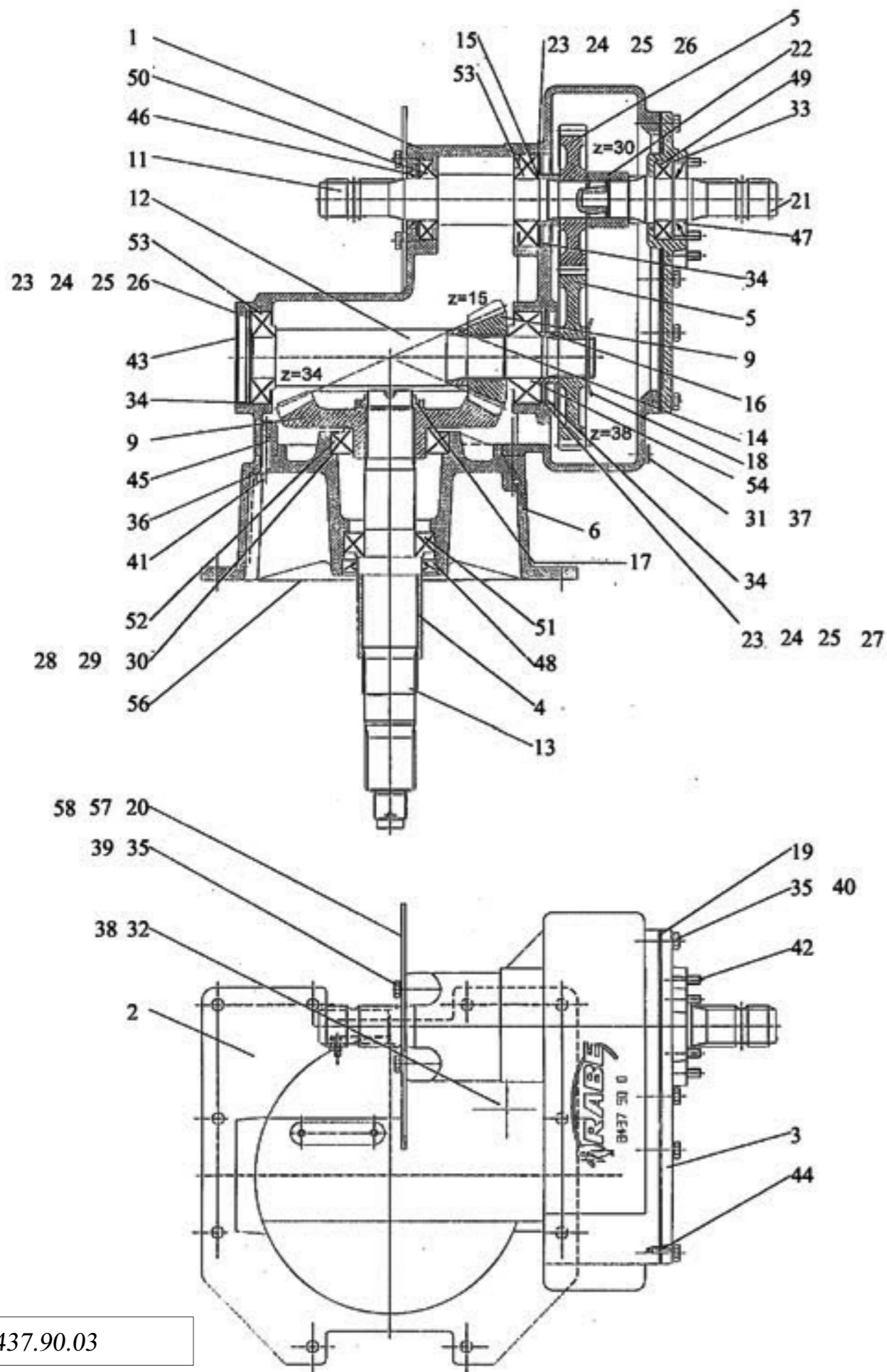

Pos. / Index	Stck. / Qty.	Artikel-Nr.	Benennung / Designation
46	1	3760D456210BA	Wellendichtring 45x62x10 BA DIN3760 Shaft sealing ring Joint de arbre
47	1	3760D458513B2	Wellendichtring 45x85x13 B2 DIN3760 Shaft sealing ring Joint de arbre
48	1	3760D7010513B2	Wellendichtring 70x105x13 B2 DIN3760 Shaft sealing ring Joint de arbre
49	1	625D6209	Rillenkugellager 6209 DIN625 Ball bearing Roulement a billes
50	1	720D30209	Kegelrollenlager 30209 DIN720 Taper roller bearing Roulement a rouleaux
51	1	720D30211	Kegelrollenlager 30211 DIN720 Taper roller bearing Roulement a rouleaux
52	1	720D30215	Kegelrollenlager 30215 DIN720 Taper roller bearing Roulement a rouleaux
53	2	720D30309	Kegelrollenlager 30309 DIN720 T aper roller bearing Roulement a rouleaux
54	1	720D32309	Kegelrollenlager 32309 DIN720 Taper roller bearing Roulement a rouleaux
55	1	8437.70.13	Deckel Lid Couvercle
56	1	8437.00.30	Getriebedichtung Gasket Joint de boite de vitesse
57	1	8437.72.99	Schutz kpl. Cover cpl. Protection cpl.
58	2	933D820PA	Sechskantschraube M8x20 DIN933-8.8 vz. Hex. bolt Vis 6 pans
	4,5	GETRIEBEOEL/5	Getriebeöl Hypoid GL 5 SAE 90 Gear oil Huile

8437.90.03

06-Feb-14

Revision :
M a J :

Durchtrieb Nachrüstsatz - 1 3/8" / PTO through drive - 1 3/8" /
Prise de force apr. - 1 3/8"

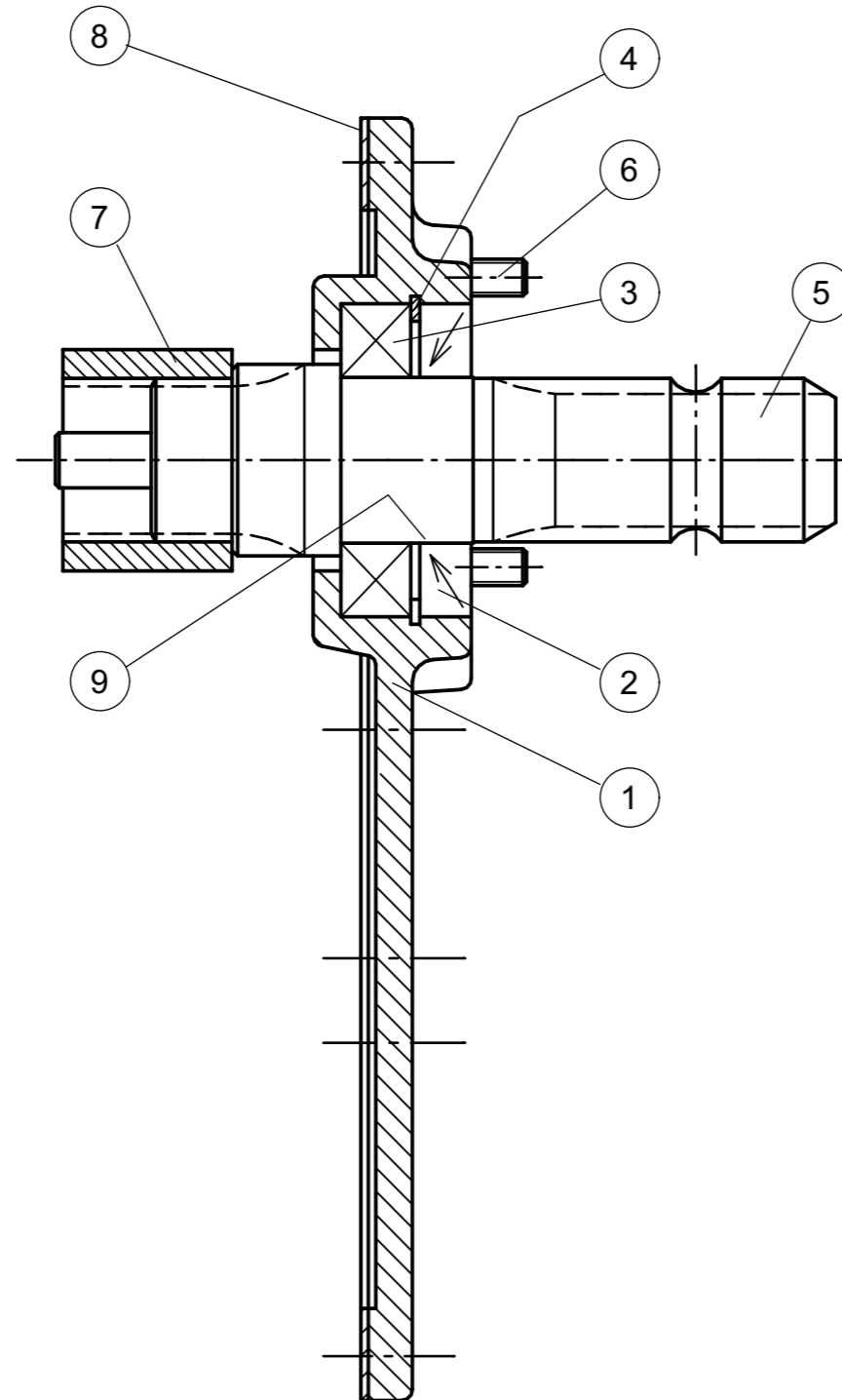
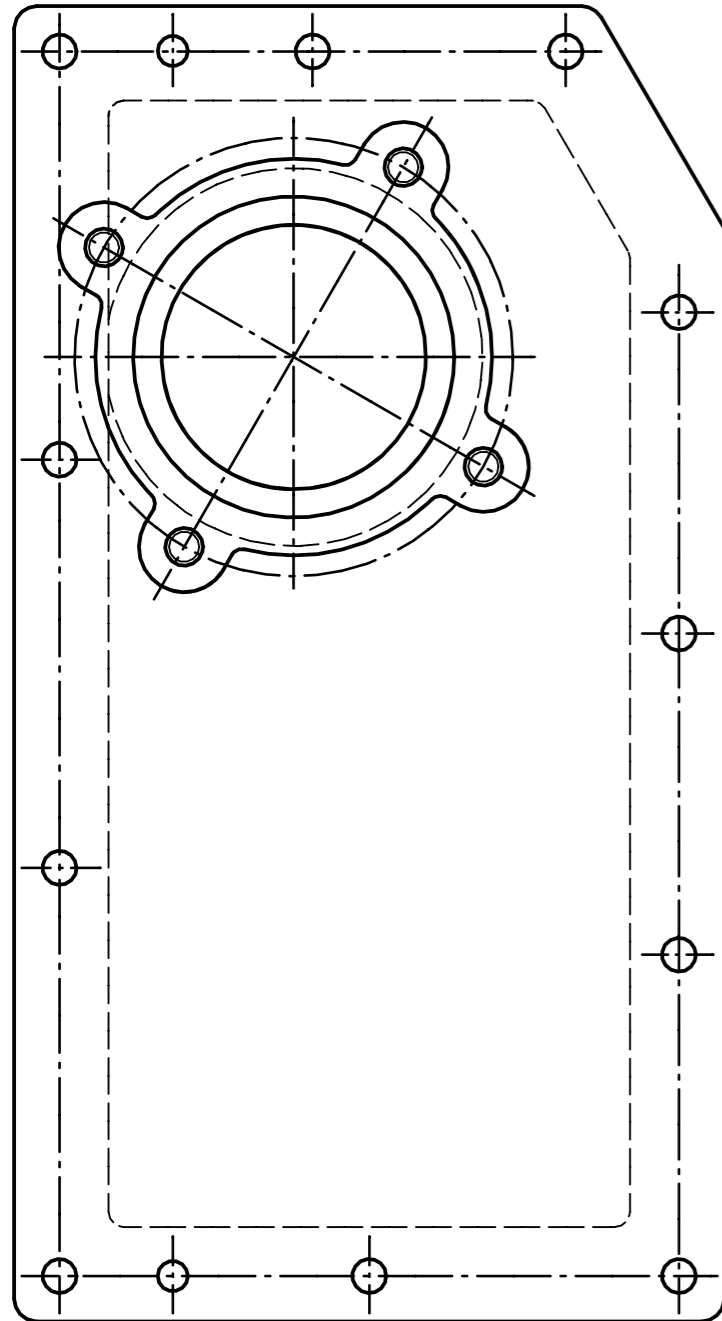

Pos. / Index	Stck. / Qty.	Artikel-Nr.	Benennung / Designation
1	1	8437.70.42	Deckel für Durchtrieb Cover Couverde
2	1	3760D458513B2	Wellendichtring 45x85x13 B2 DIN3760 Shaft sealing ring Joint de arbre
3	1	625D6209	Kugellager 6209 DIN 625 Ball bearing Roulement à billes
4	1	472D853	Sicherungsring 85x3 DIN 472 Circlip Circlip
5	1	8437.70.40	Durchtriebswelle 1 3/8" Input shaft 1 3/8" Arbre d'entree 1 3/8"
6	1	913D1030N	Gewindestift M10x30 DIN 913-10.9 Threaded pin Vis sans fete
7	1	8437.70.44	Buchse Bush Douille
8	1	8437.70.22	Deckeldichtung Cover gasket Joint de couvercle
9	1	471D45175	Sicherungsring 45x1,75 DIN 471 Circlip Circlip

Durchtrieb Nachrüstsatz - 1 3/4" / PTO through drive - 1 3/4" /
Prise de force apr. - 1 3/4"

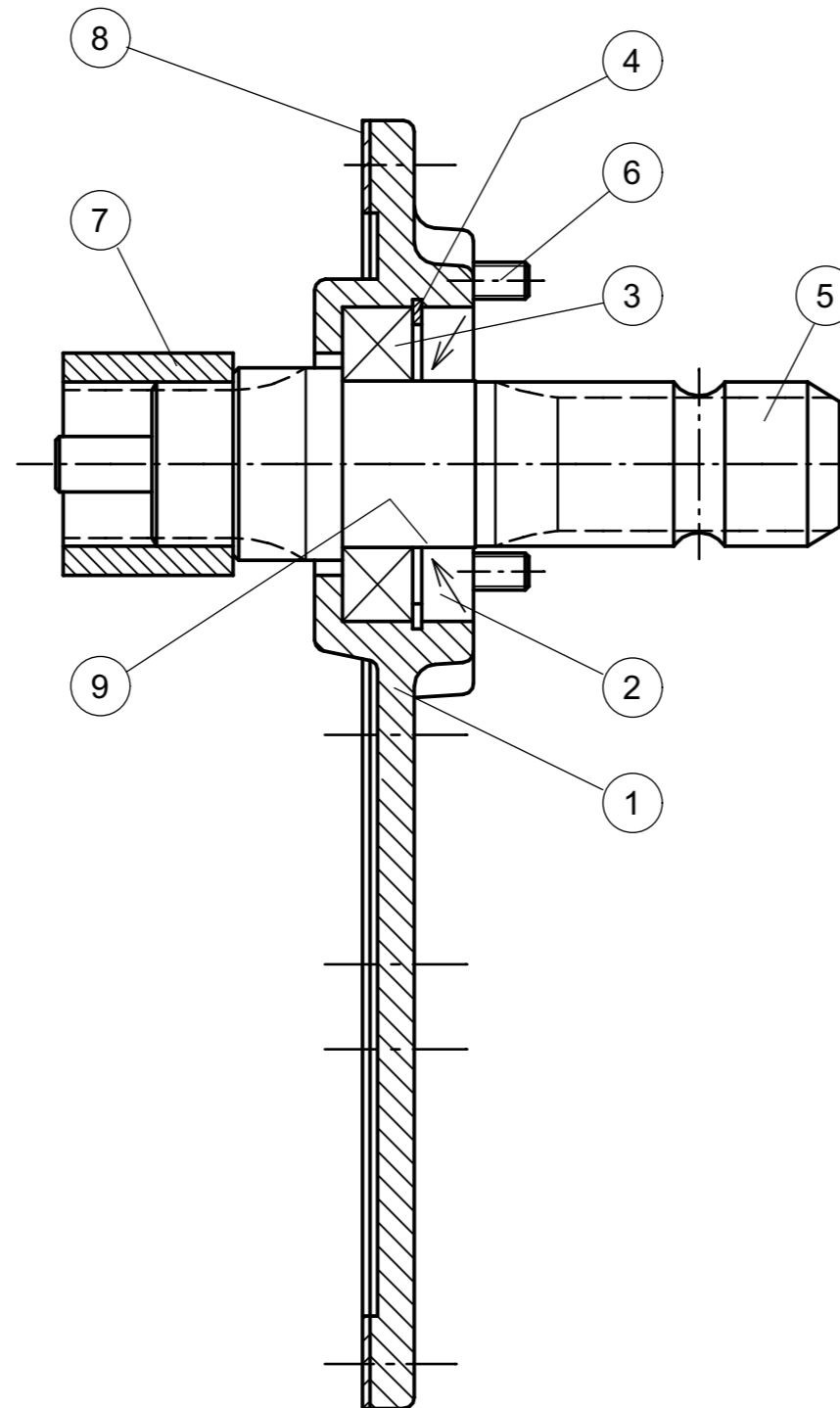
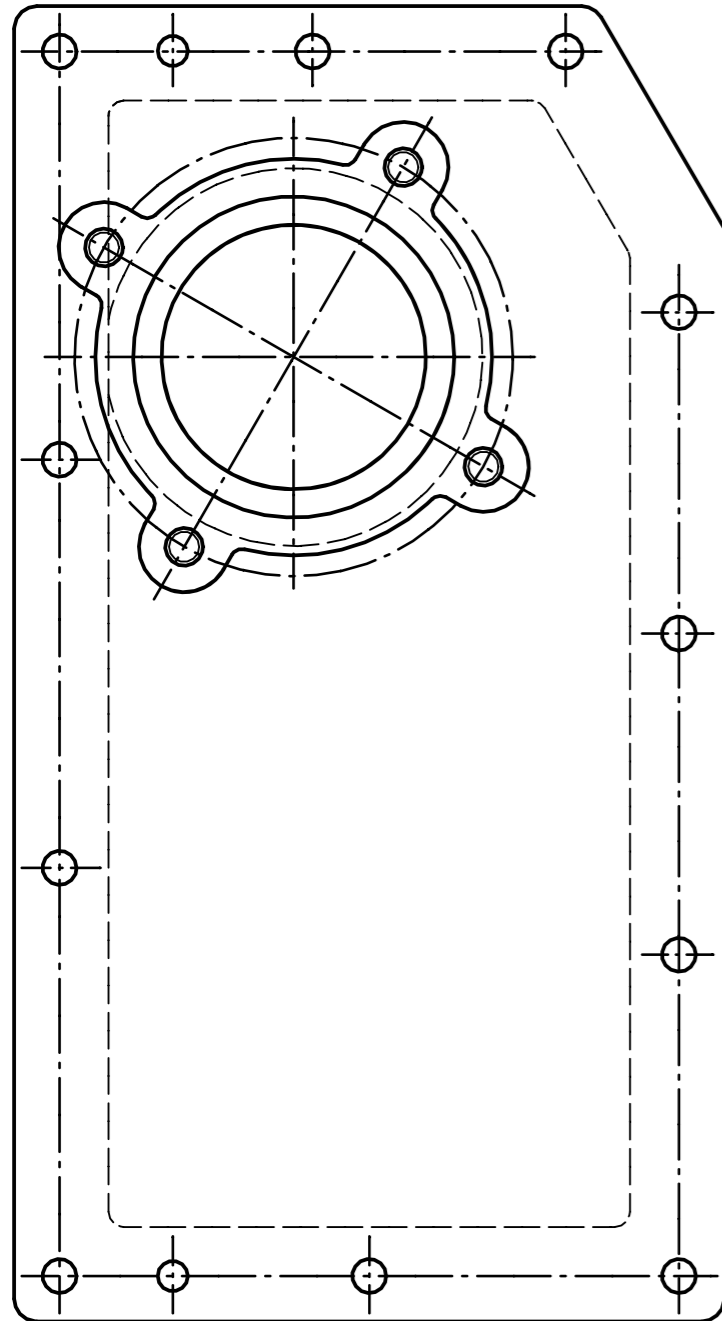

Pos. / Index	Stck. / Qty.	Artikel-Nr.	Benennung / Designation
1	1	8437.70.42	Deckel für Durchtrieb Cover Couverde
2	1	3760D458513B2	Wellendichtring 45x85x13 B2 DIN3760 Shaft sealing ring Joint de arbre
3	1	625D6209	Kugellager 6209 DIN 625 Ball bearing Roulement à billes
4	1	472D853	Sicherungsring 85x3 DIN 472 Circlip Circlip
5	1	8437.70.41	Durchtriebswelle 1 3/4" Input shaft 1 3/4" Arbre d'entree 1 3/4"
6	1	913D1030N	Gewindestift M10x30 DIN 913-10.9 Threaded pin Vis sans fete
7	1	8437.70.44	Buchse Bush Douille
8	1	8437.70.22	Deckeldichtung Cover gasket Joint de couvercle
9	1	471D45175	Sicherungsring 45x1,75 DIN 471 Circlip Circlip

Pos. / Index	Stck. / Qty	Artikel-Nr.	Benennung / Designation
1	4	934D10PA	Mutter std H M10 Verzinkt 8.8 Nut std H M10 - thread 150 Zingue Ecrou std H M10 - pas 150 Zingue
2	1	8435.03.09	Zapfwellenschutz
3	1	8437.10.07	Schutztopf
4	1	8437.10.08	Adapterring

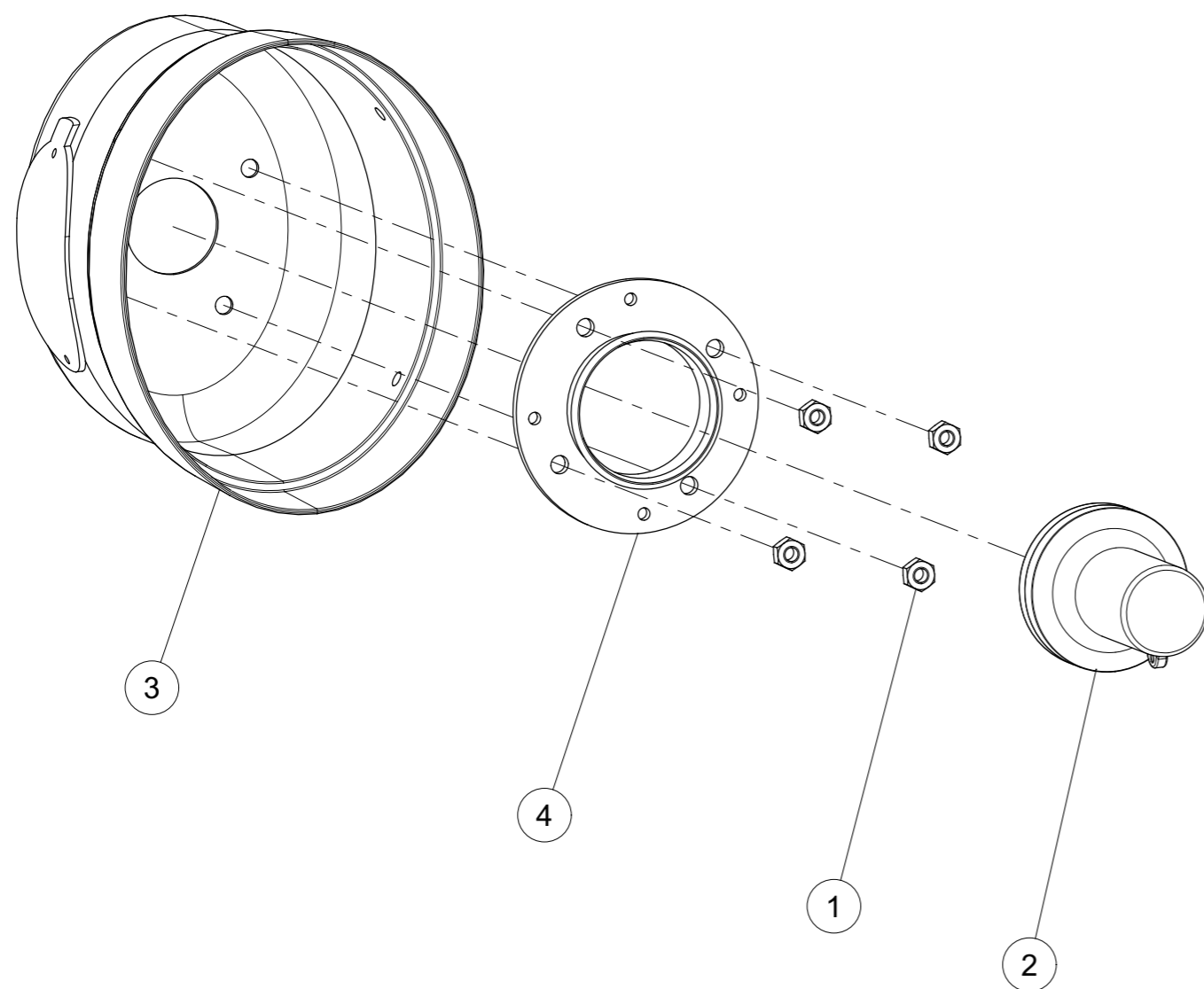

Gelenkwelle Nockenschaltkupplung

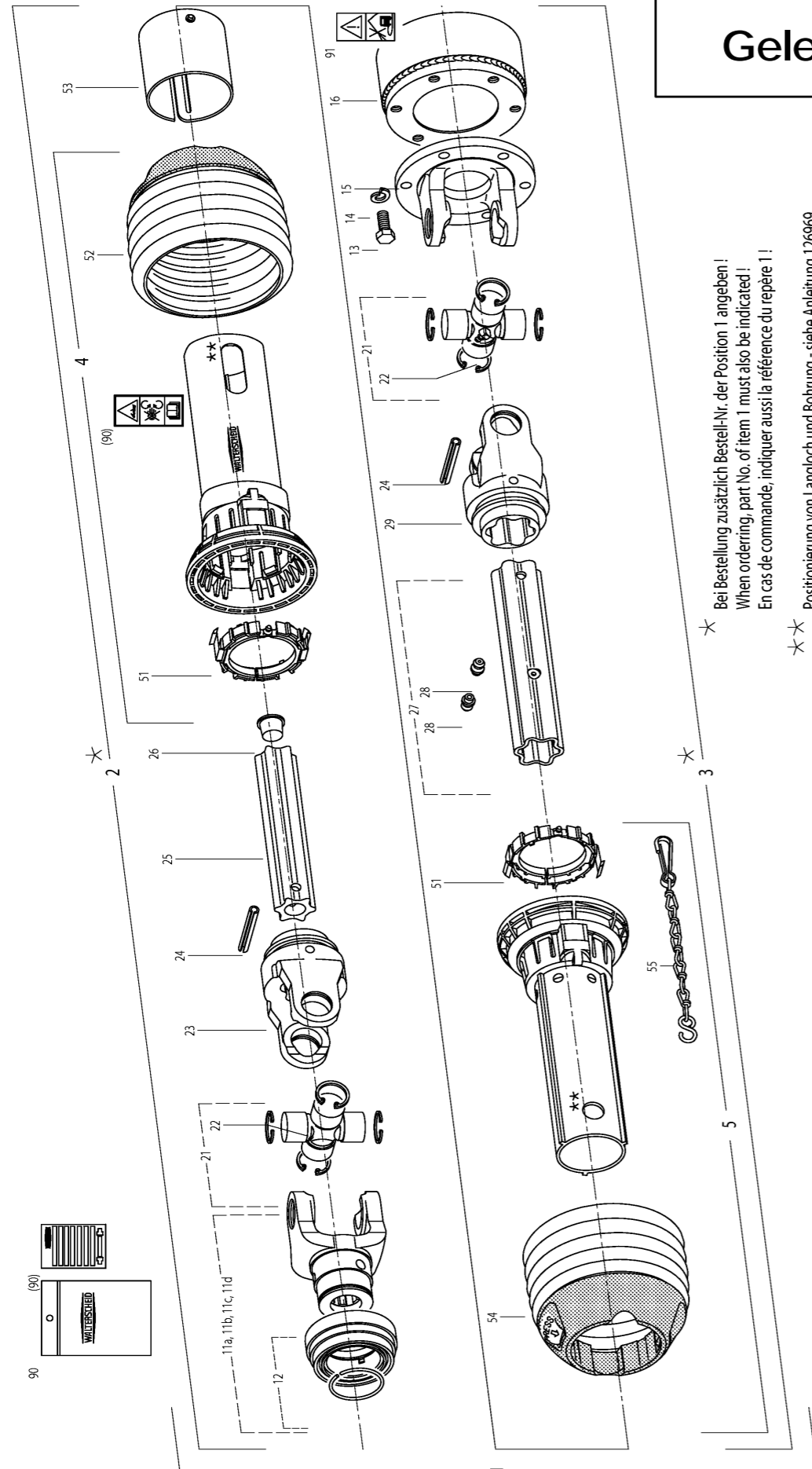

Bei Bestellung zusätzlich Bestell-Nr. der Position 1 angeben!
When ordering, part No. of item 1 must also be indicated!
En cas de commande, indiquer aussi la référence du repère 1!

Positionierung von Langloch und Bohrung - siehe Anleitung 126969
Slot and hole positioning - see instructions 126969
Positionnement du trou oblong et du trou - voir notice 126969

Pos.	Anz.	Artnr.	Benennung	designation (fra)	Designation (eng)
1	1	8433.25.01	Gelenkwelle13/8",6Z.	Transmission	P.T.O.driveshaft
1		8433.25.02	Gelenkwelle13/8",21Z.	Transmission	P.T.O.driveshaft
1		8433.25.03	Gelenkwelle13/4",6Z.	Transmission	P.T.O.driveshaft
1		8433.25.04	Gelenkwelle13/4",20Z.	Transmission	P.T.O.driveshaft
2	*	1			
3	*	1			
4		1161261	Schutzhälfte,außen	Demis-protecteurextérieur	Outerhalfguard
5		1161271	Schutzhälfte,innen	Demis-protecteurintérieur	Innerhalfguard
11a		366798	Gabel	Machoire	Yoke
11b		1366800	Gabel	Machoire	Yoke
11c		1366806	Gabel	Machoire	Yoke
11d		1366808	Gabel	Machoire	Yoke
12	1	376106	Verschluß kpl.	Piècedefermeture cpl.	Cover cpl.
13	6	020531	Sechskantschr.M12X30verz.DIN933-10.9	Vis 6 pans	Hex. bolt
14	6	020106	Federring	Rondellegrower	Springwasher
15	1	317807	Flanschgabel	Mâchoire de bride	Flange yoke
16	1	129931	Nockenschaltkupplung	Limiteur debrayable a cames	Cam-type cut out clutch
21	2	121145	Kreuzgarnitur	Bloc croisillon cpl.	Cross and bearing kit cpl.
22	2	084099	Schmiernippel	Graisneur	Grease nipple
23	1	125356	Gabel	Machoire	Yoke
24	2	304046	Spannstift	Goupille serrage	Dowel Pin
25	1	134357	Welle	Arbre	Shaft
26	1	043535	Kappe	Chapeau	Hubcap
27	1	119992	Rohr	Tube	Pipe
28	2	043427	Schmiernippel	Graisneur	Grease nipple
29	1	125321	Gabel	Machoire	Yoke
51	2	117229	Gleitring	Baque	Bush
52	1	120025	Schutztrichter	Côneprotecteur	Guardcone
53	1	198303	Abdeckung	Bouchon	Cover
54	1	120025	Schutztrichter	Côneprotecteur	Guardcone
55	1	044321	Haltekette	Chaînette	Safetychain
90	1	120777	Betriebsanleitung	Noticed'instruction	Operationmanual
91	1	117291	Aufkleber	Autocollant	Sticker
*2-91	WAL		über Walterscheid	par Walterscheid	via Walterscheid

Nockenschaltkupplung

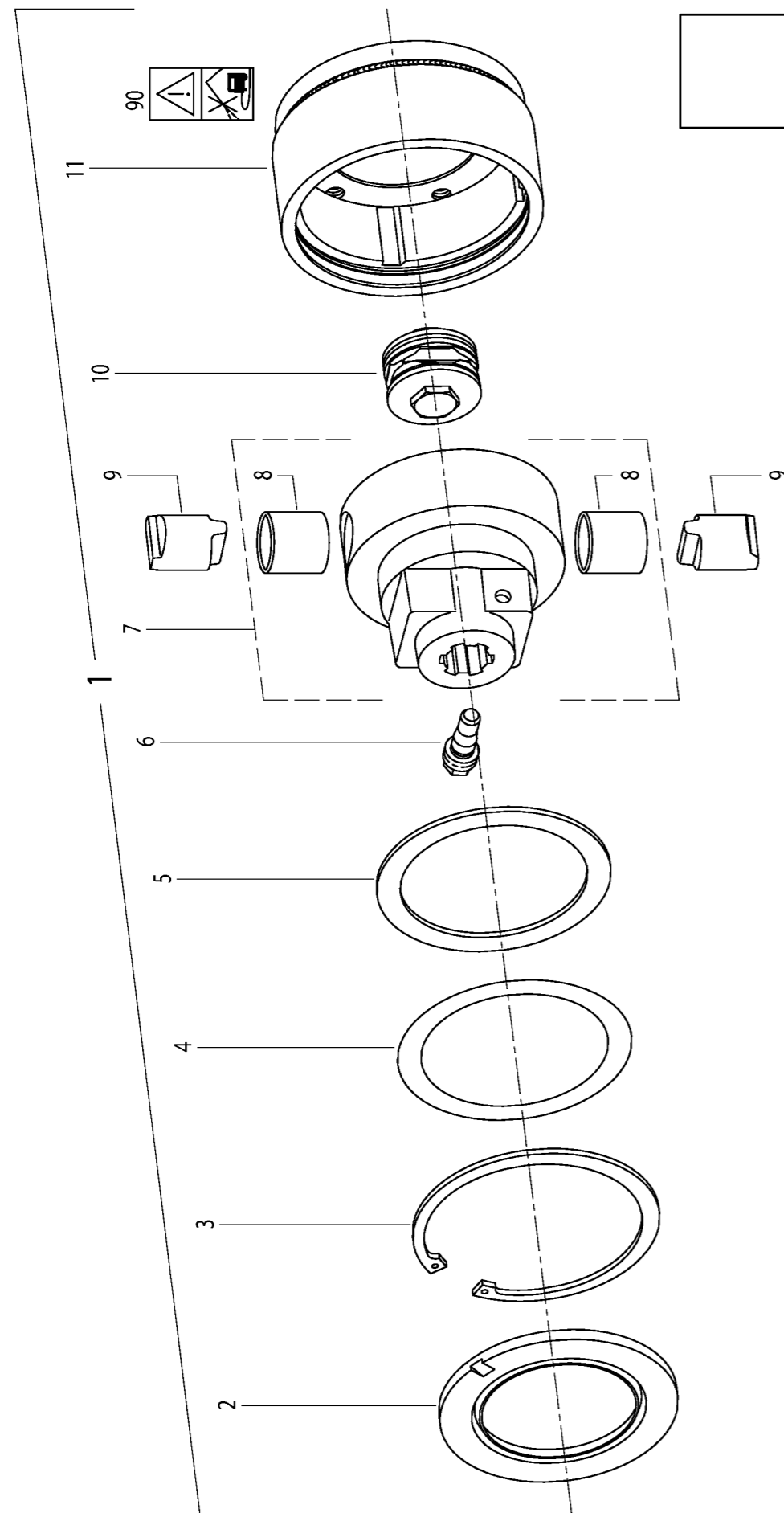

Pos.	Anz.	Artnr.	Benennung	designation (fra)	designation (eng)
1	1	129931	Nockenschaltkupplung	Limiteur debrayable a cames	Cam-type cut out clutch
2	1	161459	Dichtring	Joint	Seal ring
3	1	364499	Sicherungsring	Circlip	Circlip
4		116143	Paßscheibensatz	Jeu de rondelles de calage	Shim kit
5	1	364621	Stützscheibe	Rondelle pour bague	Supporting washer
6	1	107542	Klemm-Konus	Cone de contrainte	Clamping cone
7	1	128510	NABEKPL.13/4(6)	Moyeu	Hub
8	2	128519	Buchse	Douille	Bush
9	2	127120	Sperrnocken	Came de blocage	Locking cam
10	1	129941	Federpaket	Ressort cpl.	Spring kit
11	1	129781	Gehäuse	Carter	Housing
90	1	120777	Betriebsanleitung	Noticed'instruction	Operation manual
0	1	3042911	Spezialfett	Graisse	Grease
*2-90	WAL		über Walterscheid	par Walterscheid	via Walterscheid

129931

Gelenkwelle mit Reibkupplung

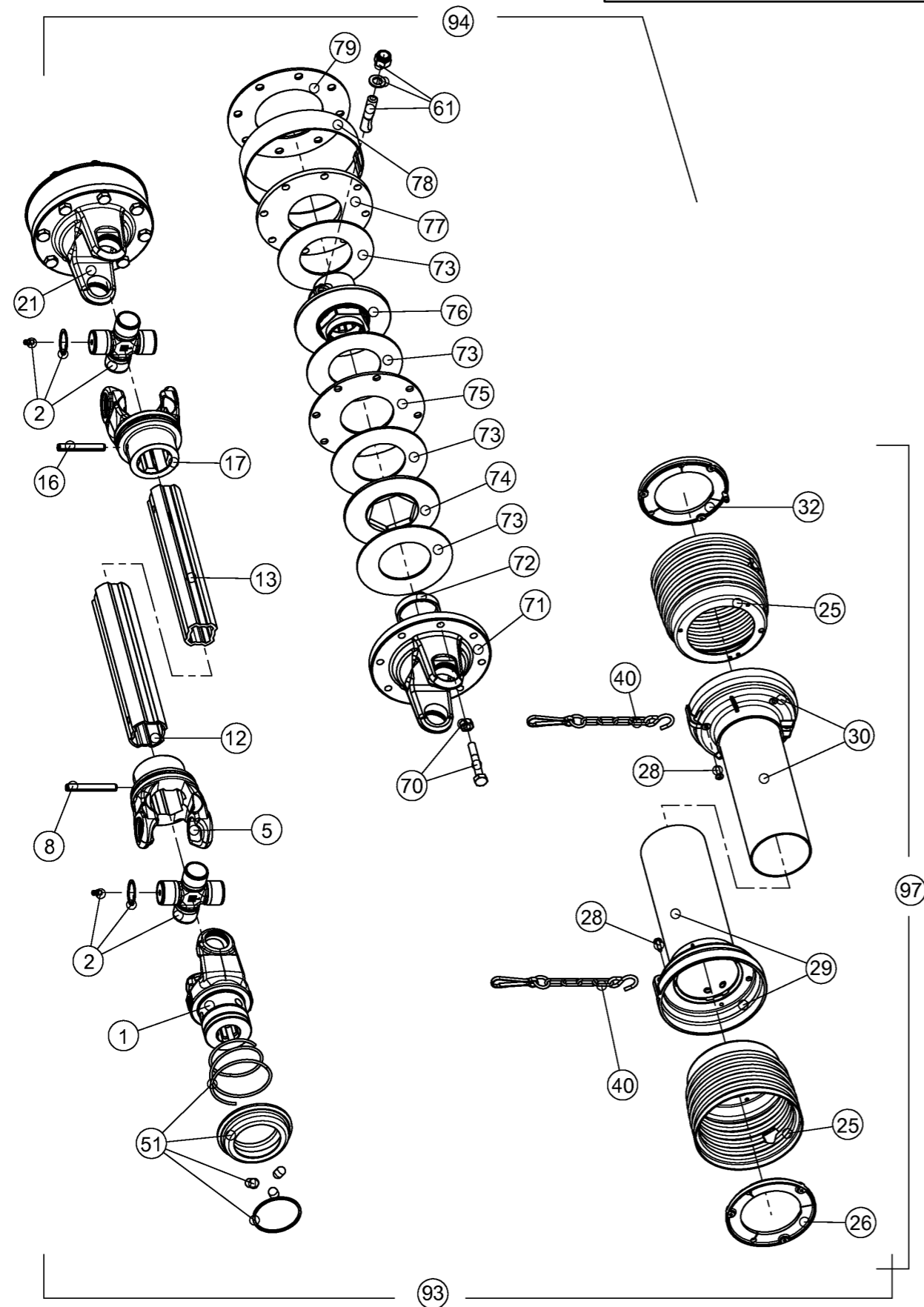

Pos.	Anz.	Artnr.	Benennung	designation (fra)	Designation (eng)
1	1	BYPY5720L03 61	Außengabel	Mâchoire extérieur	Outside yoke
2	2	BYPY4120L00 12R24	Kreuzgarnitur	Bloc croisillon cpl.	Cross and bearing kit cpl.
5	1	BYPY204S868 53	Gabel	Machoire	Yoke
8	1	BYPY3410420 00R10	Spannstift 10x76 DIN1481	Goupille serrage	Dowel Pin
12	1	BYPY2253S05 85	Profilrohr, außen	Tube profilé extérieur	Outer profile tube
13	1	BYPY2704D06 00	Profilrohr, innen	Tube profilé intérieur	Inner profile tube
16	1	BYPY3410230 00R10	Spannstift 10x70 DIN1481	Goupille serrage	Dowel Pin
17	1	BYPY204S868 54	Gabel	Machoire	Yoke
21	1	BYPY663L583 04R	Kupplung	Limiteur	Clutch
25	2	BYPY2190L02 01	Schutzmanschette	Manchette de protection	Protective cuff
26	1	BYPY2550G00 01R02	Lauftring	Baque	Ring
28	6	BYPY3100014 31R30	Schraube 4,8x22 verz. DIN7981	Vis	Hex. bolt
29	1	BYPY5TNN1S8 076C	Rohr	Tube	Pipe
30	1	BYPY5MNN1S 8076C	Rohr	Tube	Pipe
32	1	BYPY2550G00 02R02	Lauftring	Baque	Ring
40	2	BYPY2520001 01R02	Haltekette	Chaînette	Safety chain
48	1	BYPY3991430 00	Aufkleber USA	Autocollant	Sticker
49	1	BYPY399CEE0 51	Schmierplan	Plan de lubrification	Lubrication diagram
50	1	BYPY399CEE0 11	Betriebsanleitung	Notice d'instruction	Operation manual
51	1	BYPY4350003 12R	Verschuß	Pièce de fermeture	Cover
61	1	BYPY4080000 49R02	Klemmschraube	Vis de serrage	Clamping srew
70	8	BYPY4320000 45R08	Sechskantschraube M 10x65 mit Mutter	Vis 6 pans avec ecrou	Hex. bolt with nut
71	1	BYPY2530786 01	Flanschgabel	Mâchoire de bride	Flange yoke
72	1	BYPY2580053 20R02	Gleitring	Baque	Bush
73	4	BYPY2470062 51R08	Scheibe	Rondelle	Washer
74	1	BYPY2487277 02	Scheibe	Rondelle	Washer
75	1	BYPY2488600 01	Druckscheibe	Rondelle	Tension ring
76	1	BYPY5158904 05	Nabe	Moyeu	Hub
77	1	BYPY2488600 05	Scheibe	Rondelle	Washer
78	1	BYPY2400002 18	Ring	Anneau	Ring
79	1	BYPY367FT34 0D	Tellerfeder	Ressort bellavil	Cup spring
*1-79		BYPY	über Bondioli & Pavesi	par Bondioli & Pavesi	via Bondioli & Pavesi

8444.08.01 - 02

Pos. / Index	Stck. / Qty	Artikel-Nr.	Benennung / Designation
1	1	8446.00.28	Lagerarm li.
2	1	8446.00.29	Lagerarm re.

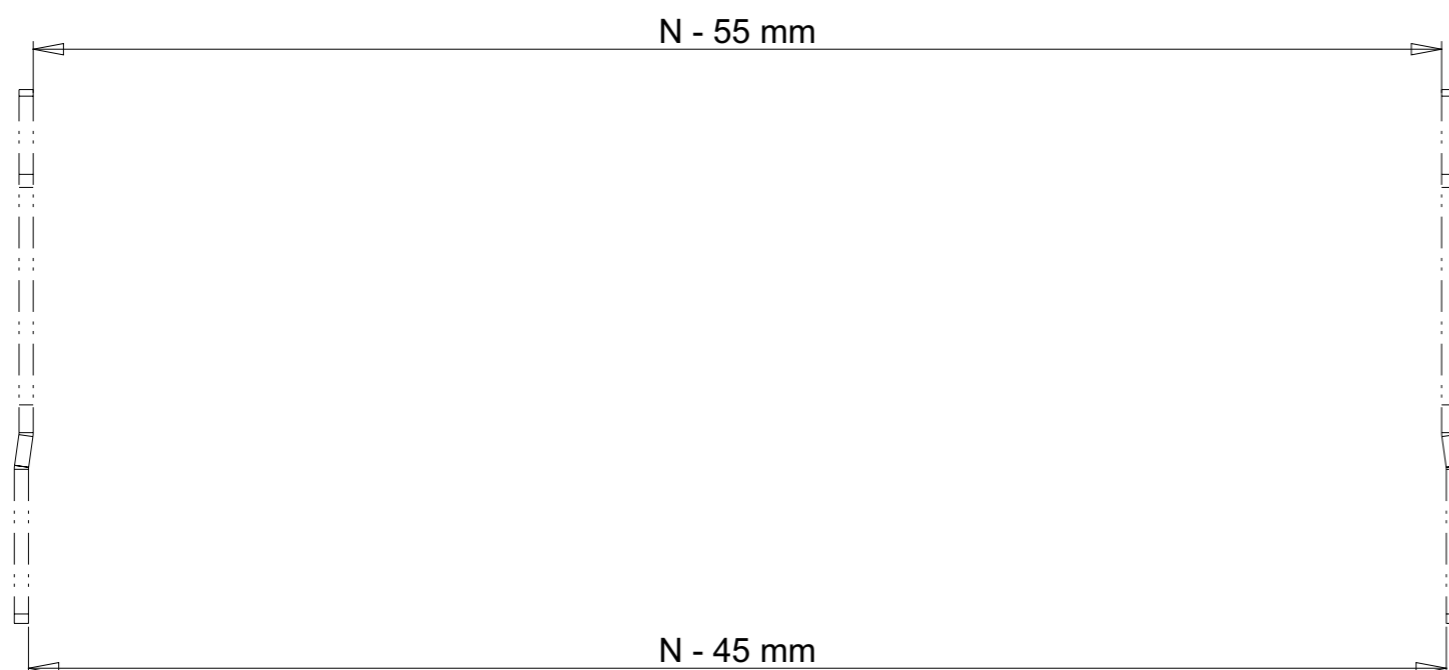

N = Nennbreite Gerät [mm]

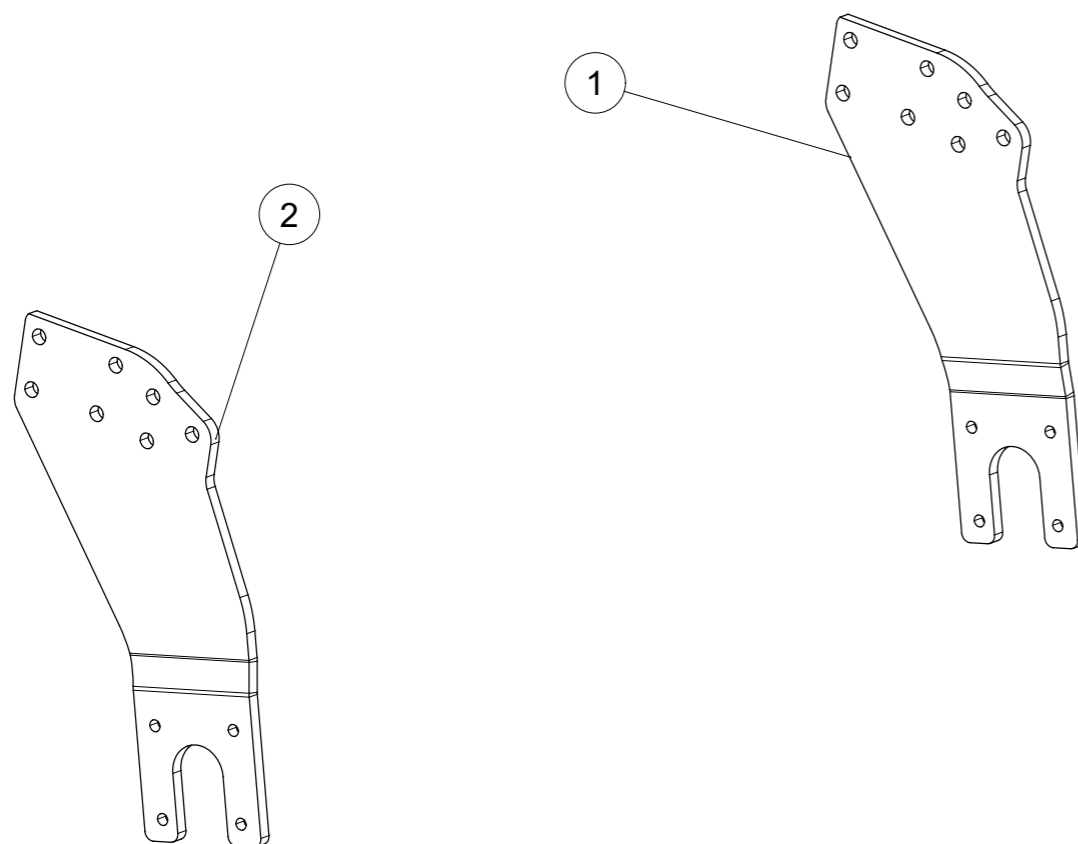

Pos. / Index	Stck. / Qty	Artikel-Nr.	Benennung / Designation
1	1	8446.0032	Lagerarm über D550 re.
2	1	8446.00.31	Lagerarm über D550 li.

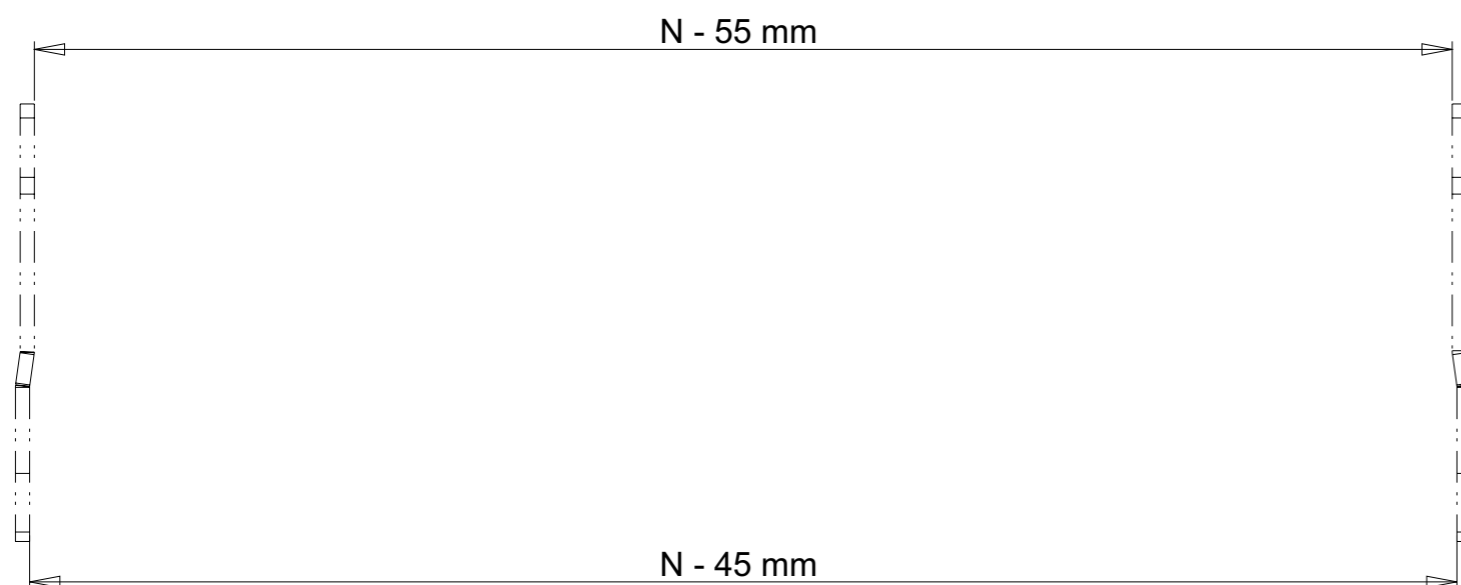

N = Nennbreite Gerät [mm]

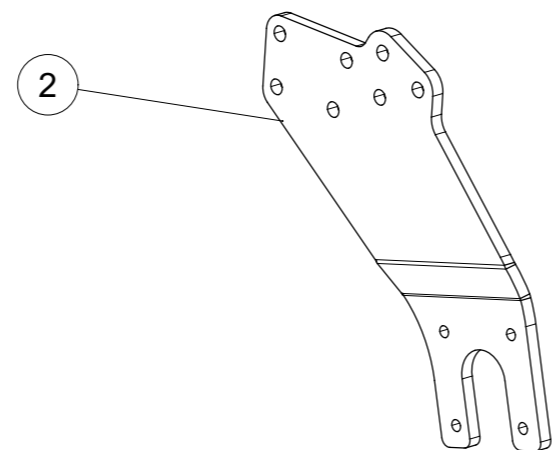
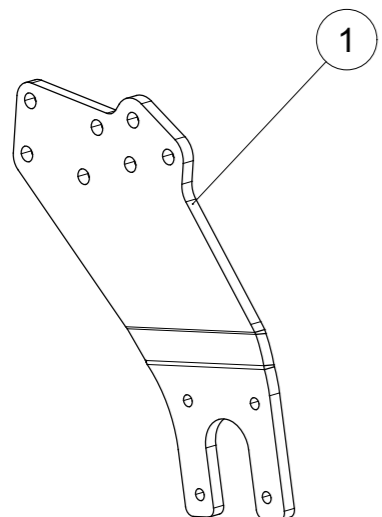

Stabpackerwalze D540 3,0m kpl.

Pos. / Index	Stck. / Qty	Artikel-Nr.	Benennung / Designation
1	2	8406.25.12	Flansch SQ132x10-D13xSQ101.5 mm
2	1	8406.74.19	Stabwalze \varnothing 540 3,00m
3	2	8432.00.34	Scheibe D13
4	2	8432.23.01	Flanschlager mont. verst. D40
5	2	933D1235NA	hex. Schraube M12x35 ISO4017-10.9 verzinkt Hex. Screw M12x35 ISO4017-10.9 Zinc Vis H M12x35 ISO4017-10.9 ZNBL
6	8	980DV12PA	Sicherungsmutter M12 Verzinkt 8.8 Nut M12 Zinc 8.8 Ecrou M12 ZNBL 8.8
7	1	SPEZIALFETT	MOLYDAG_47 0.002kg
8	8	VI 29 12	Schraube H M12x 55 - 8.8 ZNBL Screw H M12x 55 - 8.8 ZNBL Vis H M12x 55 - 8.8 ZNBL

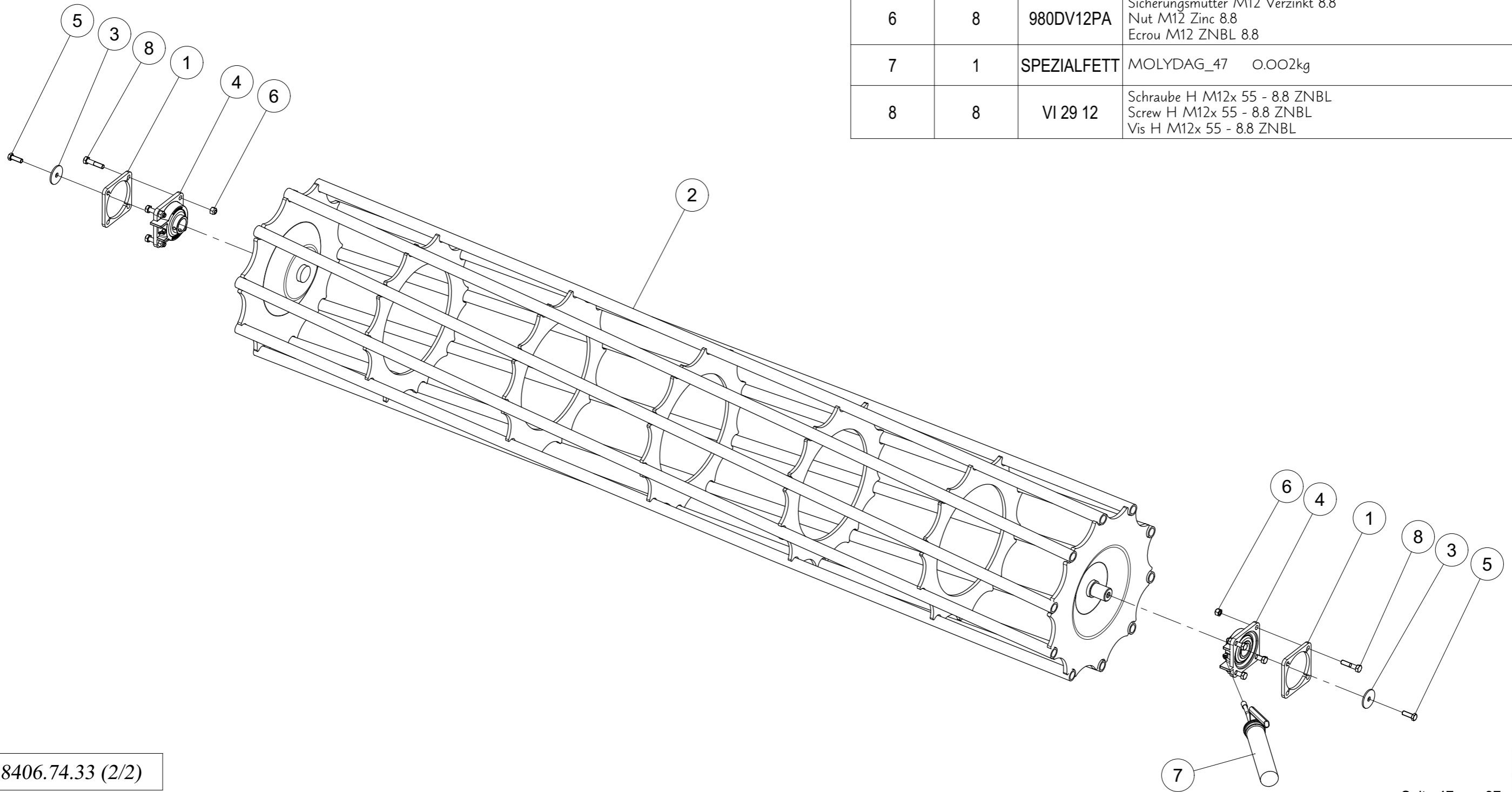

8406.74.33 (2/2)

11-Mär-14

Revision : A
M a J :

Zahnpackerwalze GZW 510 - 125 3.0 kpl.

Pos. / Index	Stck. / Qty	Artikel-Nr.	Benennung / Designation
1	8	931D1290NA	Hex. Schraube M12 x 90 Verzinkt 10.9 Hex. Screw M12 x 90 Zinc 10.9 Vis H M12 x 90 ZNBL 10.9
2	2	933D1235NA	hex. Schraube M12x35 ISO4017-10.9 verzinkt Hex. Screw M12x35 ISO4017-10.9 Zinc Vis H M12x35 ISO4017-10.9 ZNBL
3	8	980DV12NA	Sicherungsmutter M12 Verzinkt 10.9 Nut M12 Zinc 10.9 Ecrou M12 ZNBL 10.9
4	1	6810.01.23	GZW 510 3.0m gs. (125)
5	1	8406.53.61	Abstreifer 3.0m (GZW) (125)
6	2	8434.29.01	Flanschlager Ø55 kpl.
7	2	8434.29.09	Scheibe
8	1	SPEZIALFETT	MOLYDAG_47 0.002kg

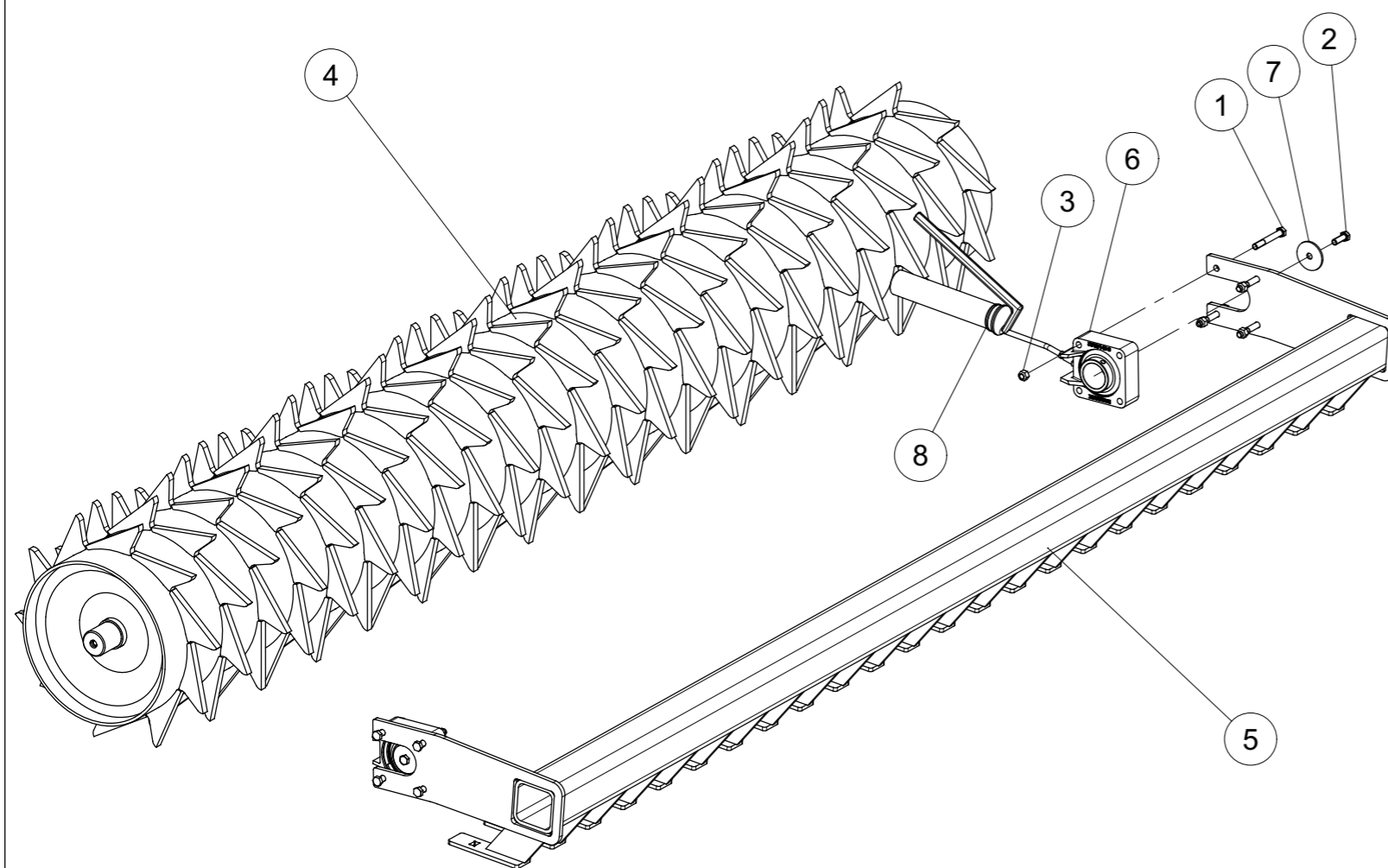

Abstreifer GZW unbeschichtet

Pos. / Index	Stck. / Qty	Artikel-Nr.	Benennung / Designation
1	1	603D1230PA	FL_RD_S. M12x30 ISO8677-8.8 Z
2	1	934D12PA	Mutter std H M12 Verzinkt 8.8 Nut std H M12 - thread 175 Zingue Ecrou std H M12 - pas 175 Zingue
3	1	7349D13A	SCHEIBE 13 DIN7349 verzinkt
4	1	8405.00.27	Abstreiferblech

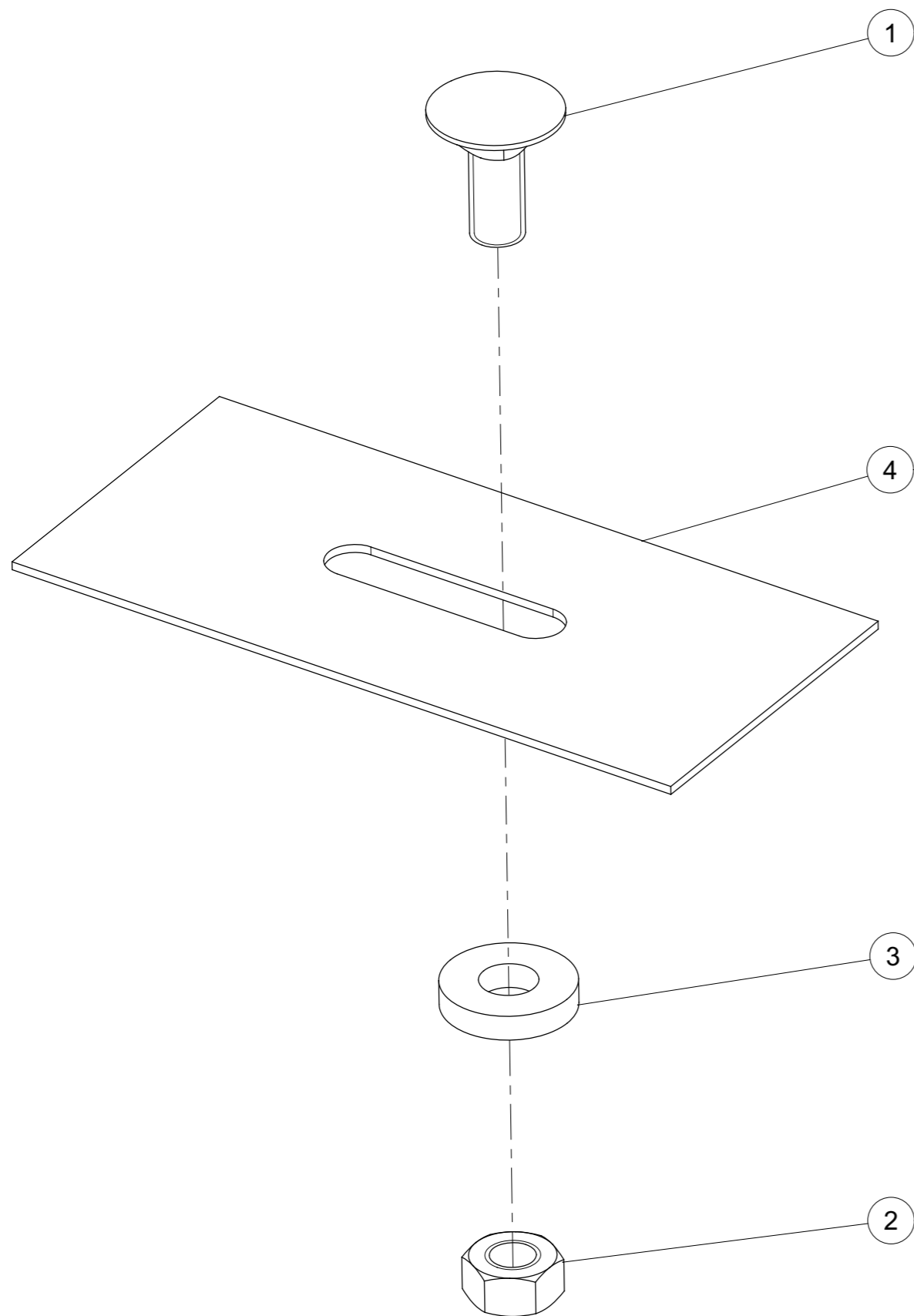

Pos. / Index	Stck. / Qty	Artikel-Nr.	Benennung / Designation
1	1	603 D1230 PA	FL_RD_S. M12x30 ISO8677-8.8 Z Round-head bolt M12x30 ISO8677-8.8 Z Vis TRCC M12x30 ISO8677-8.8 ZNBL
2	1	7349D13A	SCHEIBE 13 DIN7349 verzinkt
3	1	8406.00.09	Abstreiferblech
4	1	934D12PA	Mutter std H M12 Verzinkt 8.8 Nut std H M12 - thread 175 Zingue Ecrou std H M12 - pas 175 Zingue

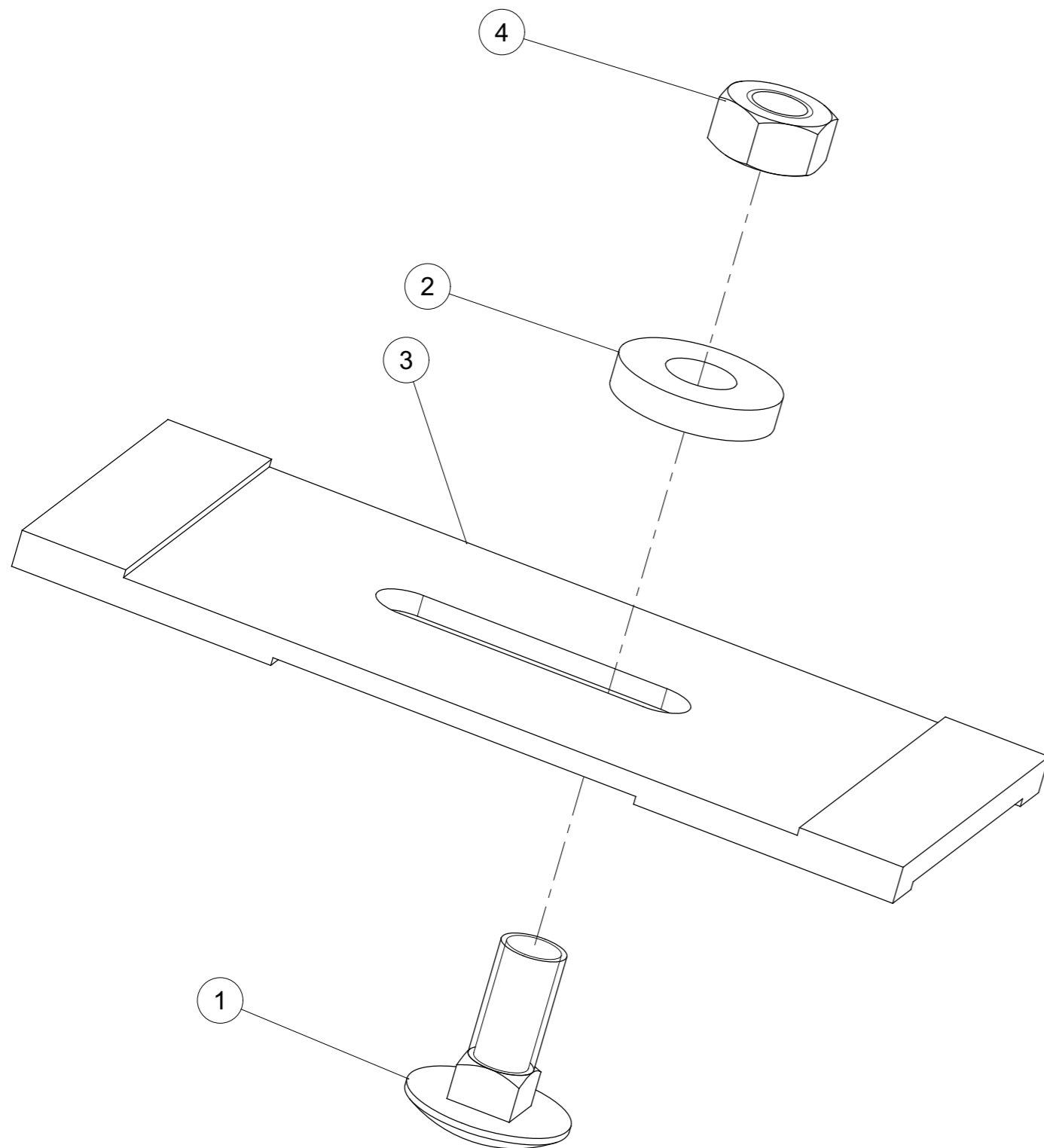

MPW 500/2 3.0 m Abst. u. mont.

Pos. / Index	Stck. / Qty	Artikel-Nr.	Benennung / Designation
1	1	6813.34.60	MPW 500/2 - 3.0 m mont.
2	1	6814.99.58	Abstreifer 3,0 m mont.
3	8	931D1290PA	Hex. Schraube M12 x 90 Verzinkt 8.8 Hex. Screw M12 x 90 Zinc 8.8 Vis H M12 x 90 ZNBL 8.8
4	8	980DV12PA	Sicherungsmutter M12 Verzinkt 8.8 Nut M12 Zinc 8.8 Ecrou M12 ZNBL 8.8

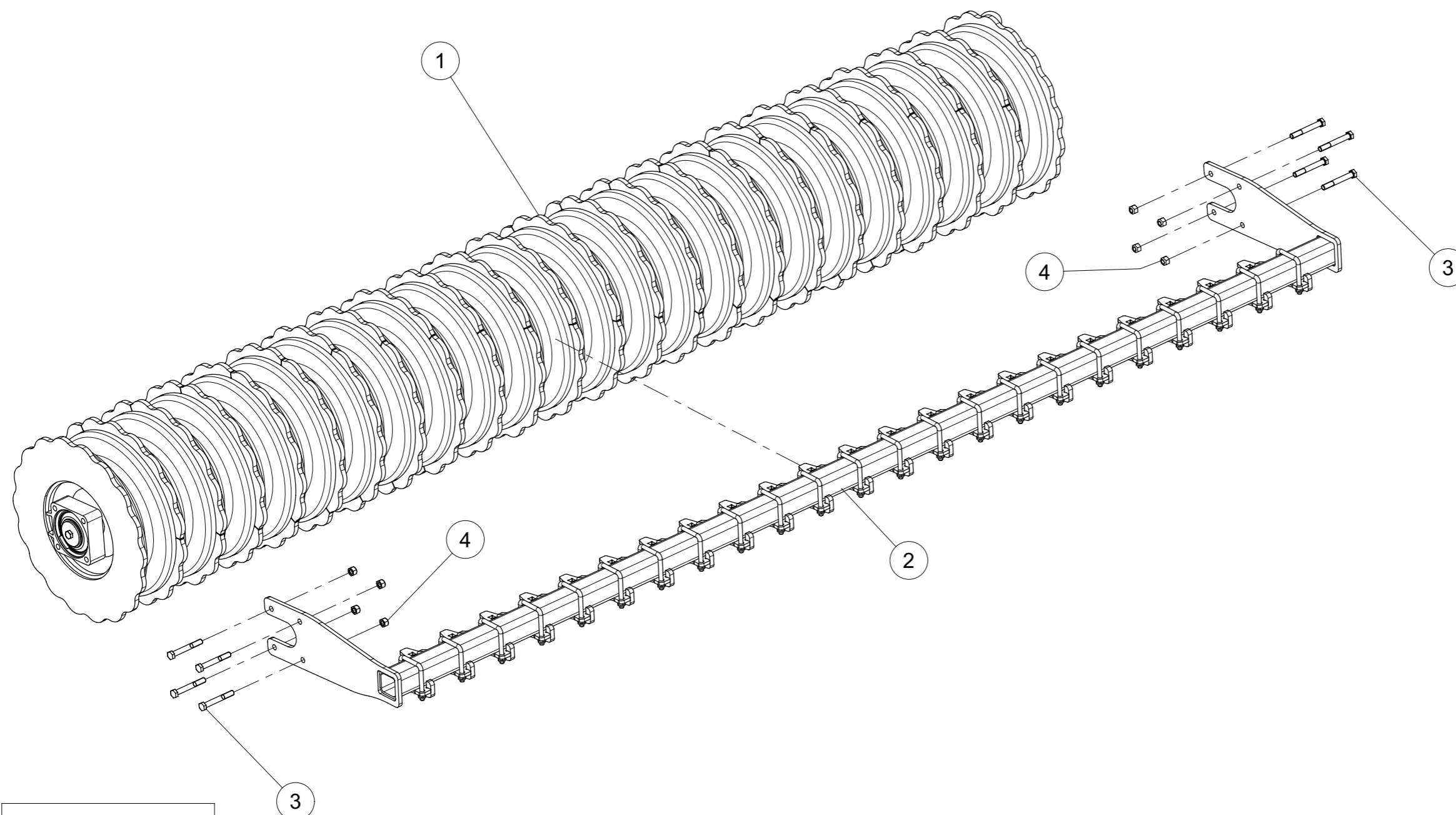

6813.34.31 (3/3)

MPW 500/2 - 3.0 m mont.

Pos. / Index	Stck. / Qty	Artikel-Nr.	Benennung / Designation
1	1	6813.34.01	MPW 500 / 2- 3,0 m geschw.
2	2	8434.29.01	Flanschlager Ø 55 kpl.
3	2	8434.29.09	Scheibe
4	2	933D1235NA	hex. Schraube M12x35 ISO4017-10.9 verzinkt Hex. Screw M12x35 ISO4017-10.9 Zinc Vis H M12x35 ISO4017-10.9 ZNBL
5	1	SPEZIALFETT	MOLYDAG_47 0.002kg

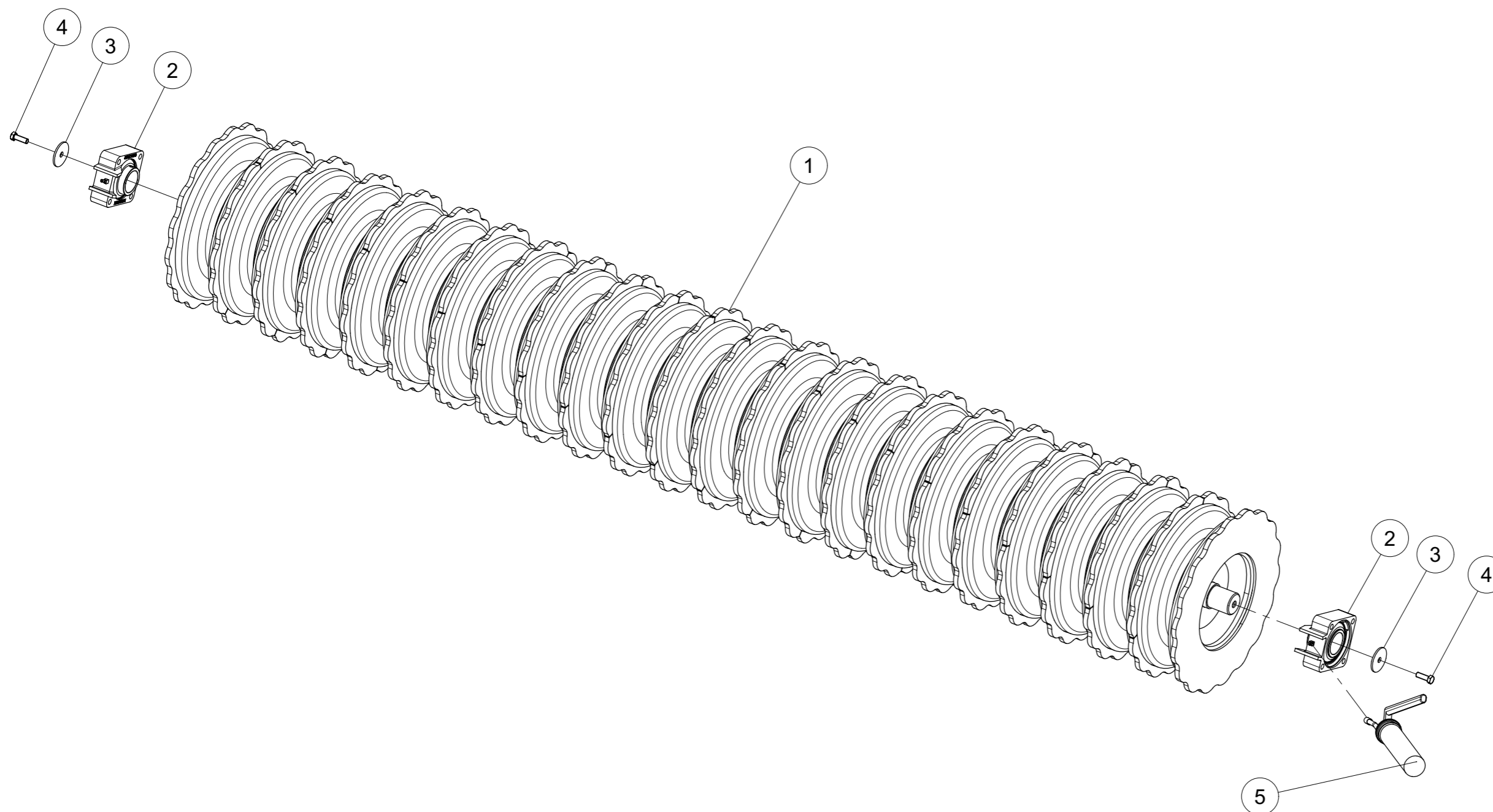

Abstreifer 3,0 m mont.

Pos. / Index	Stck. / Qty	Artikel-Nr.	Benennung / Designation
1	23	6814.99.51	Abstreifer geschw.
2	1	8406.53.53	Abstreiferbalken Ripa - O 3.0m geschw.
3	23	8406.53.58	Schraubband M10x71x90 verz.
4	46	985D10PA	SICHM. M10 ISO10511-8 Z Nyloc Nut M10 ISO10511-8 Z Ecrou HFR M10 ISO10511-8 Z

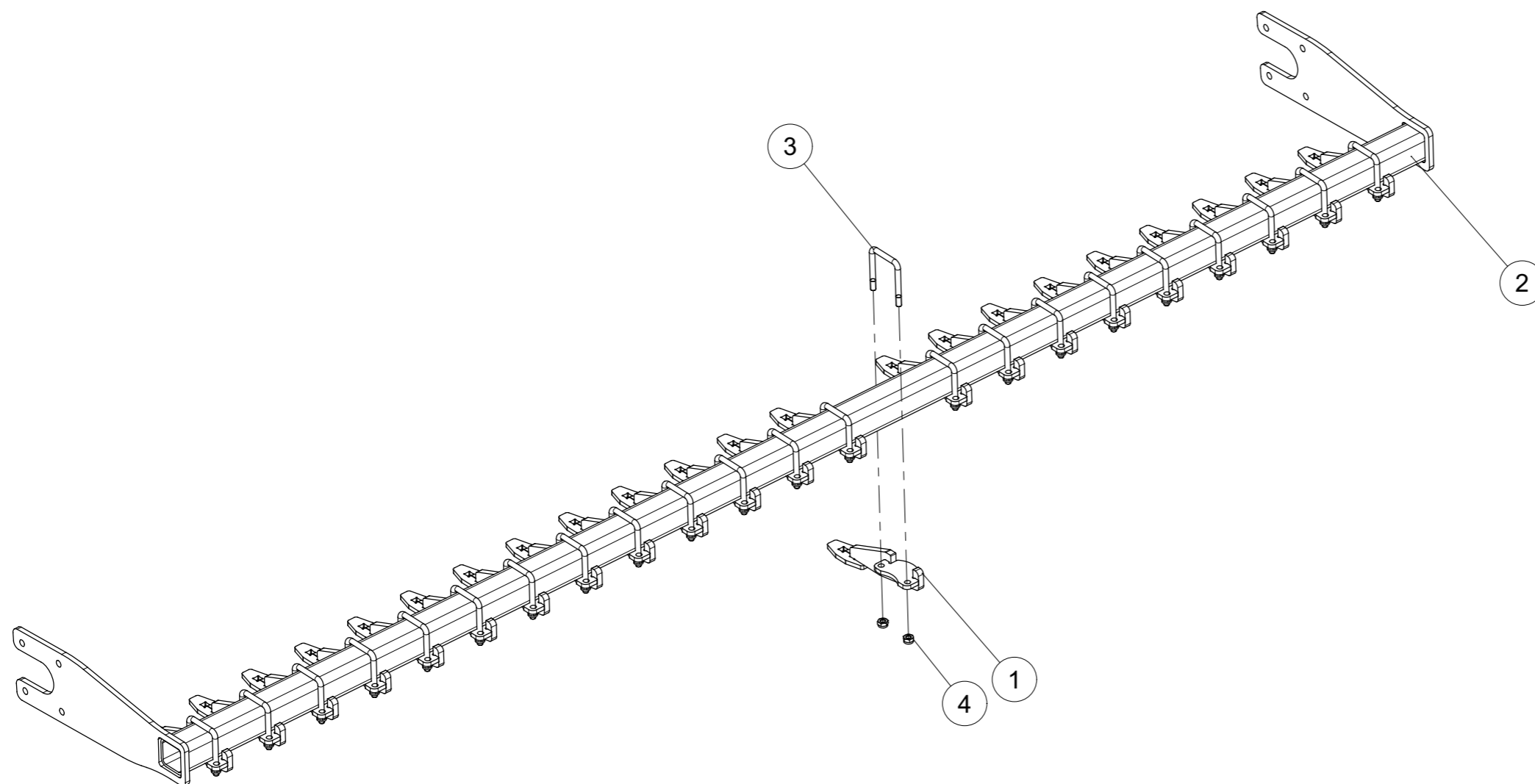

6814.99.58 (2/2)

Abstreiferbl. Dual- M12 - gehaertet kpl.

Pos. / Index	Stck. / Qty	Artikel-Nr.	Benennung / Designation
1	1	125DA13A	SCHEIBE A 13 ISO7089 VERZ. Washer A 13 ISO7089 Zinc. Rondelle A 13 ISO7089 Zinguée
2	1	603D1230PA	FL_RD_S. M12x30 ISO8677-8.8 Z
3	1	6813.26.09	Abstreiferblech -Dual -M12 - gehaertet
4	1	985D12PA	SICHM. M12 ISO10511-8 Z Nyloc Nut M12 ISO10511-8 Z Ecrou HFR M12 ISO10511-8 Z

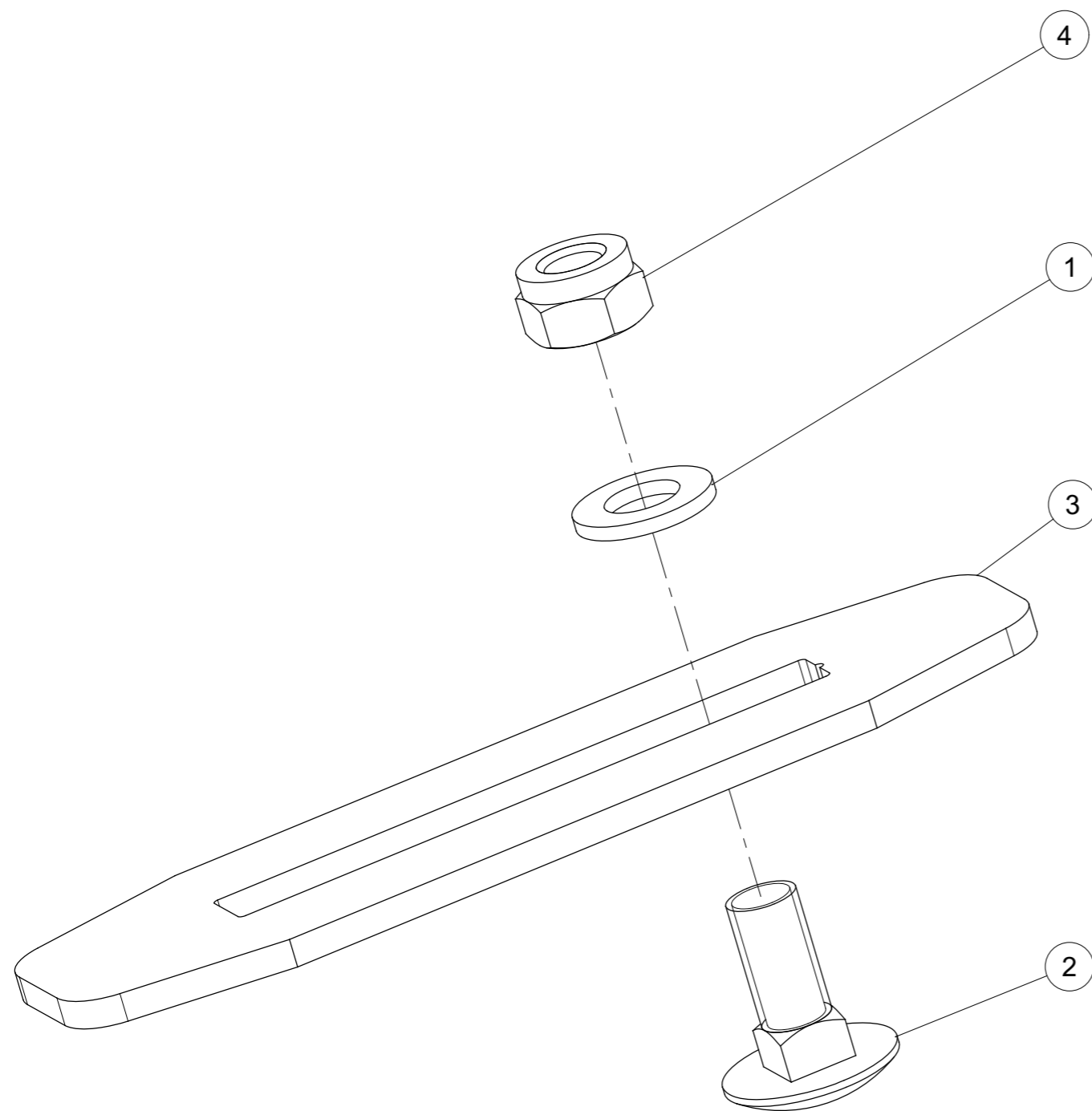

Abstreiferblech DUAL M12 SET HARD 53

Pos. / Index	Stck. / Qty	Artikel-Nr.	Benennung / Designation
1	1	603 D1235 PA	FL_RD_S. M12x35 ISO8677-8.8 Z Round-head bolt M12x35 ISO8677-8.8 Z Vis TRCC M12x35 ISO8677-8.8 ZNBL
2	1	125DA13A	SCHEIBE A 13 ISO7089 VERZ. Washer A 13 ISO7089 Zinc. Rondelle A 13 ISO7089 Zinguée
3	1	6813.27.52	Abstreiferblech -Dual -M12 - HARD 53
4	1	985D12PA	SICHM. M12 ISO10511-8 Z Nyloc Nut M12 ISO10511-8 Z Ecrou HFR M12 ISO10511-8 Z

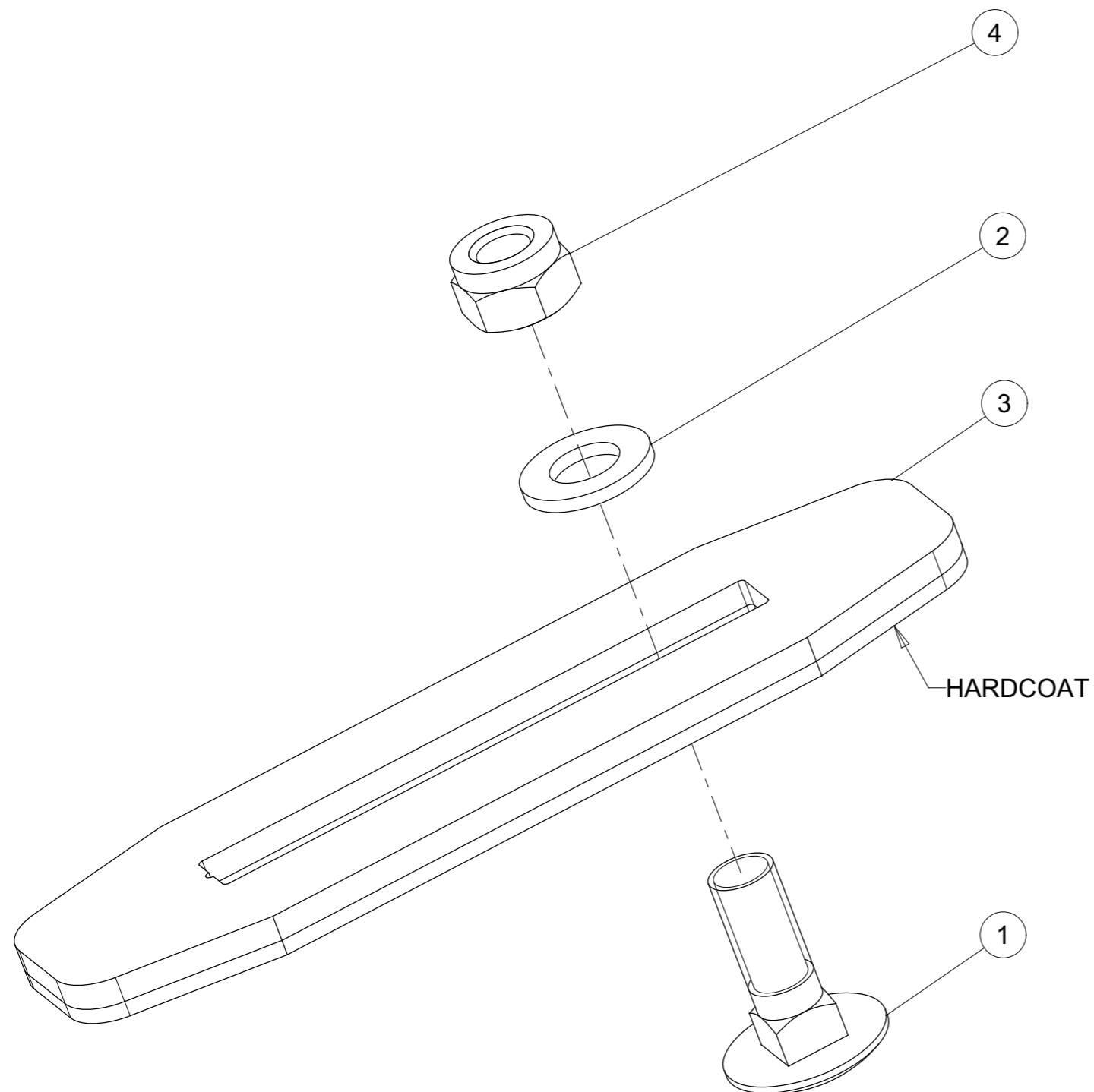

Ripa -O 580 3,0 m Abstr. unten kpl.

Pos. / Index	Stck. / Qty	Artikel-Nr.	Benennung / Designation
1	1	6814.27.60	Ripa -O 580 - 3,0 m mont.
2	1	8406.53.67	Abstreiferbalken Ripa-O 3,0 m mont.
3	8	931D1290NA	Hex. Schraube M12 x 90 Verzinkt 10.9 Hex. Screw M12 x 90 Zinc 10.9 Vis H M12 x 90 ZNBL 10.9
4	8	980DV12NA	Sicherungsmutter M12 Verzinkt 10.9 Nut M12 Zinc 10.9 Ecrou M12 ZNBL 10.9

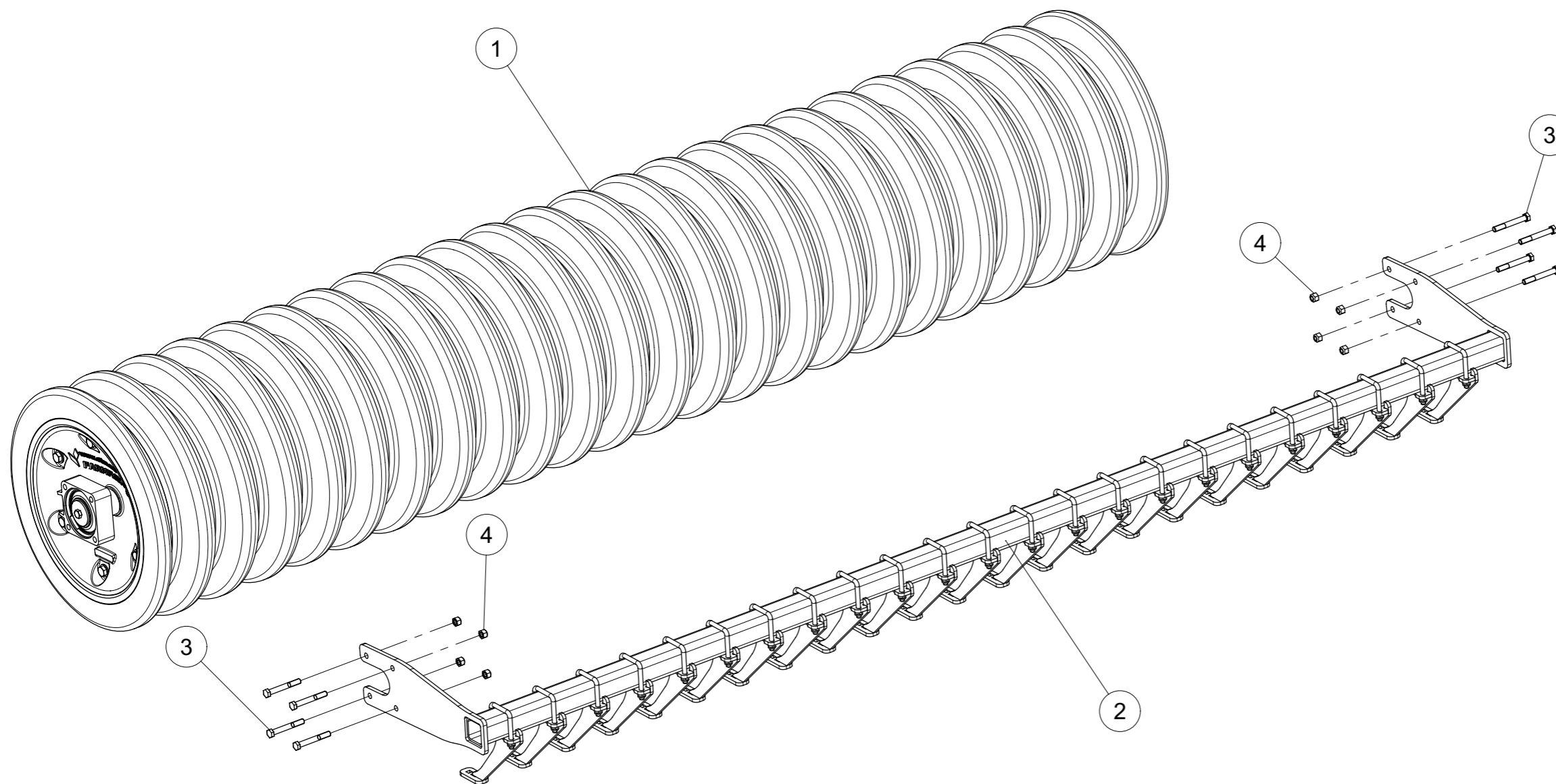

Ripa -O 580 - 3,0 m mont.

Pos. / Index	Stck. / Qty	Artikel-Nr.	Benennung / Designation
1	1	6814.27.03	Ripa O - 580 3m
2	2	8434.29.01	Flanschlager \varnothing 55 kpl.
3	2	8434.29.09	Scheibe
4	2	933D1235NA	hex. Schraube M12x35 ISO4017-10.9 verzinkt Hex. Screw M12x35 ISO4017-10.9 Zinc Vis H M12x35 ISO4017-10.9 ZNBL
5	1	SPEZIALFETT	MOLYDAG_47 0.002kg

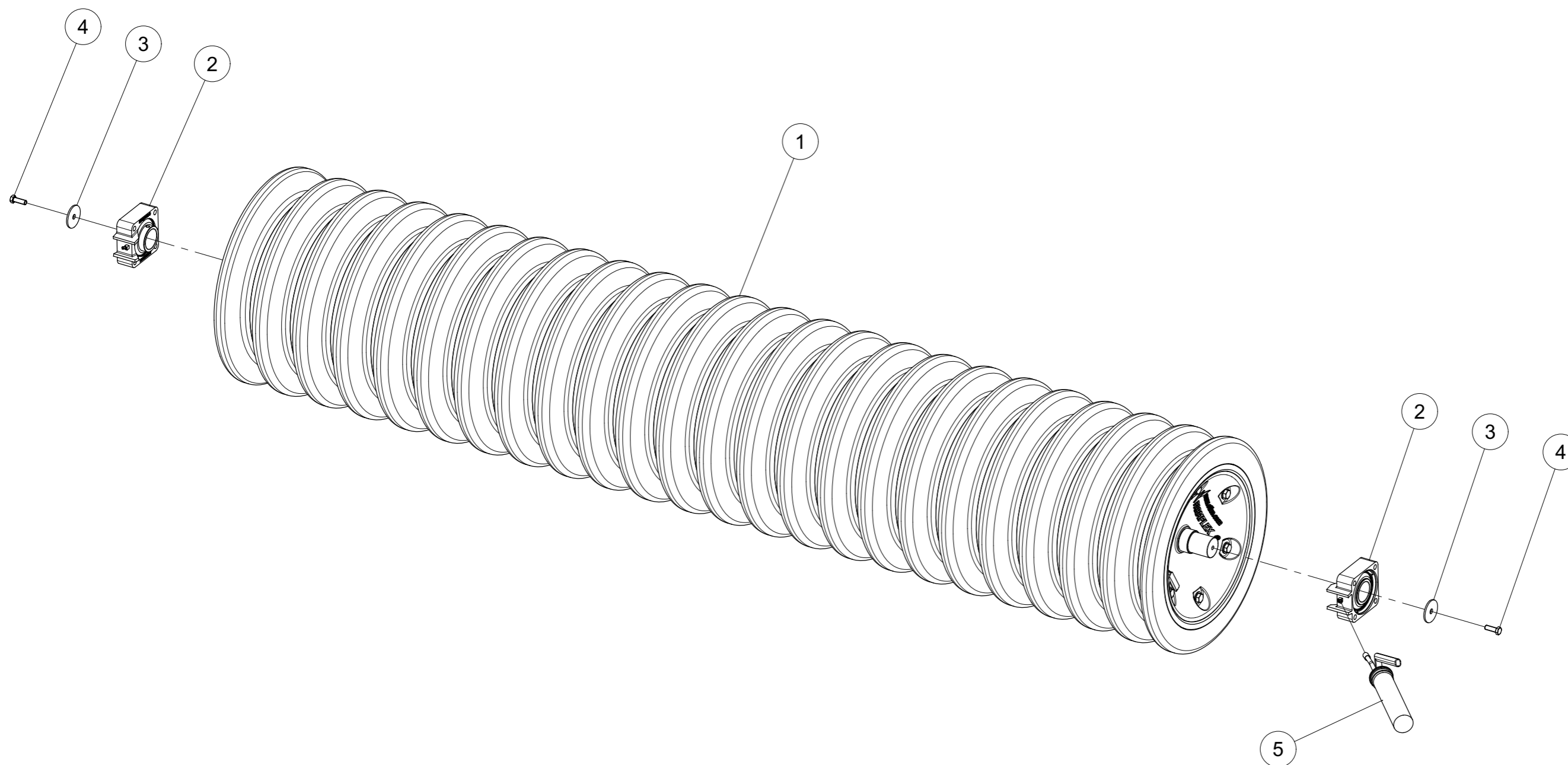

Abstreiferbalken Ripa-O 3,0 m mont.

Pos. / Index	Stck. / Qty	Artikel-Nr.	Benennung / Designation
1	23	6814.99.52	Abstreifer gs.
2	1	8406.53.53	Abstreiferbalken Ripa - O 3.0m geschw.
3	23	8406.53.58	Schraubband M10x71x90 verz.
4	46	985D10PA	SICHM. M10 ISO10511-8 Z Nyloc Nut M10 ISO10511-8 Z Ecrou HFR M10 ISO10511-8 Z

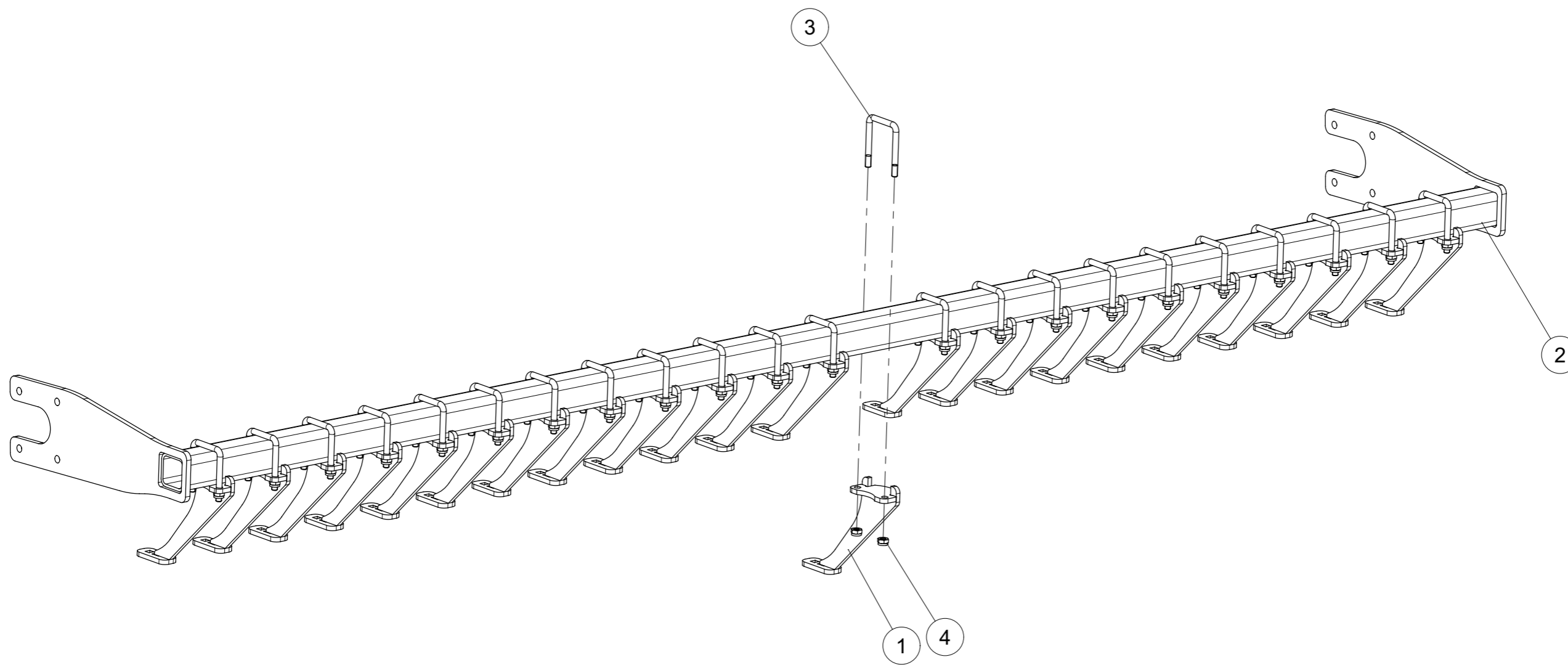

Abstreiferblech gehärtet RIPA-O kpl.

Pos. / Index	Stck. / Qty	Artikel-Nr.	Benennung / Designation
1	1	603D1030PA	FL_RD_S. M10x30 ISO8677-8.8 Z
2	1	6814.99.66	Abstreiferblech - gehärtet RIPA-O
3	1	7349D10.5A	SCHEIBE 10,5 DIN7349 verzinkt
4	1	934D10PA	Mutter std H M10 Verzinkt 8.8 Nut std H M10 - thread 150 Zingue Ecrou std H M10 - pas 150 Zingue

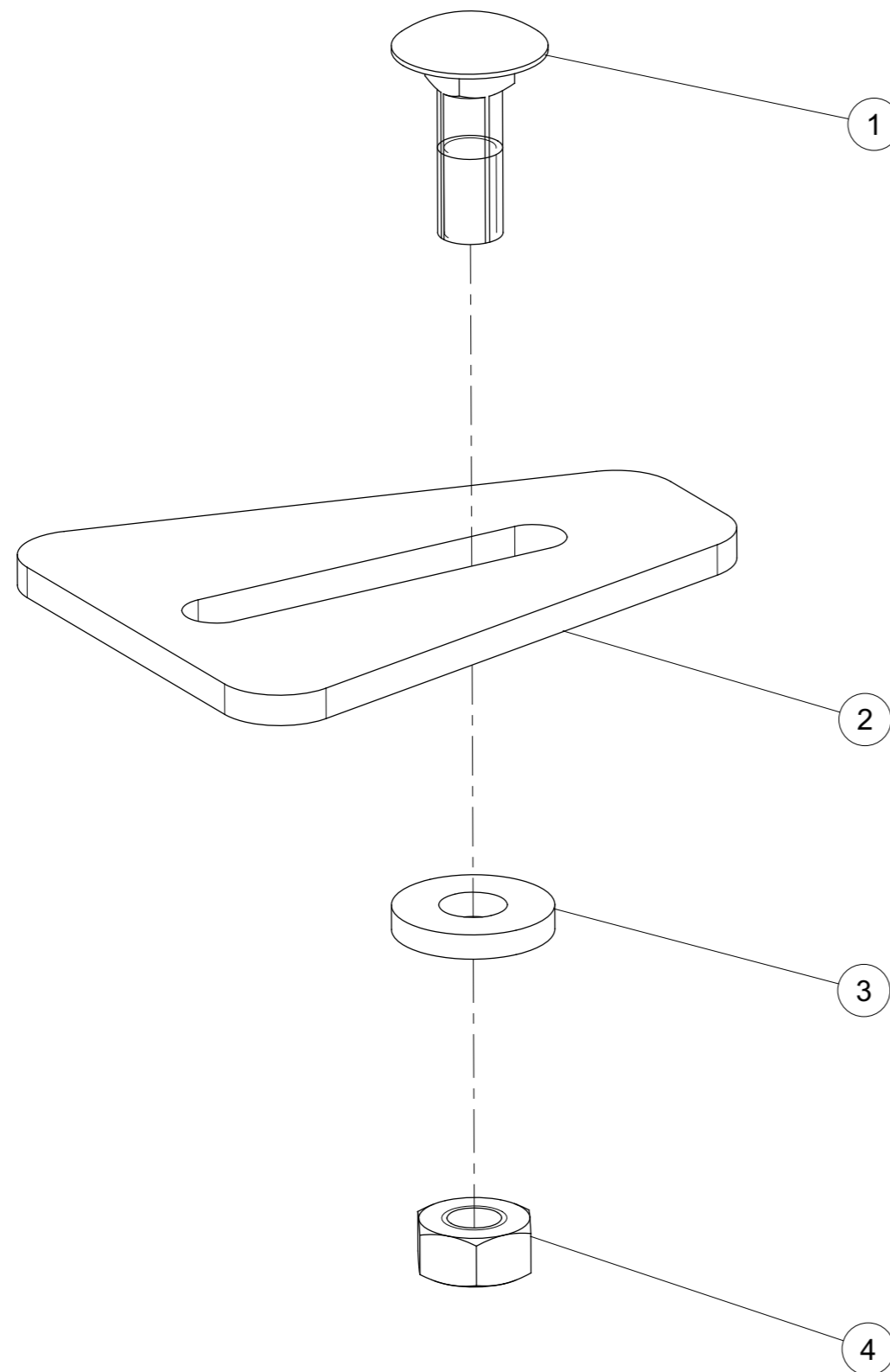

Abstreiferblech - M10 HARD 53 kpl.

Pos. / Index	Stck. / Qty	Artikel-Nr.	Benennung / Designation
1	1	603 D1030 PA	FL_RD_S. M10x30 ISO8677-8.8 Z Round-head bolt M10x30 ISO8677-8.8 Z Vis TRCC M10x30 ISO8677-8.8 ZNBL
2	1	6814.99.39	Abstreiferblech - M10 HARD 53
3	1	7349D10.5A	SCHEIBE 10,5 DIN7349 verzinkt
4	1	934D10PA	Mutter std H M10 Verzinkt 8.8 Nut std H M10 - thread 150 Zingue Ecrou std H M10 - pas 150 Zingue

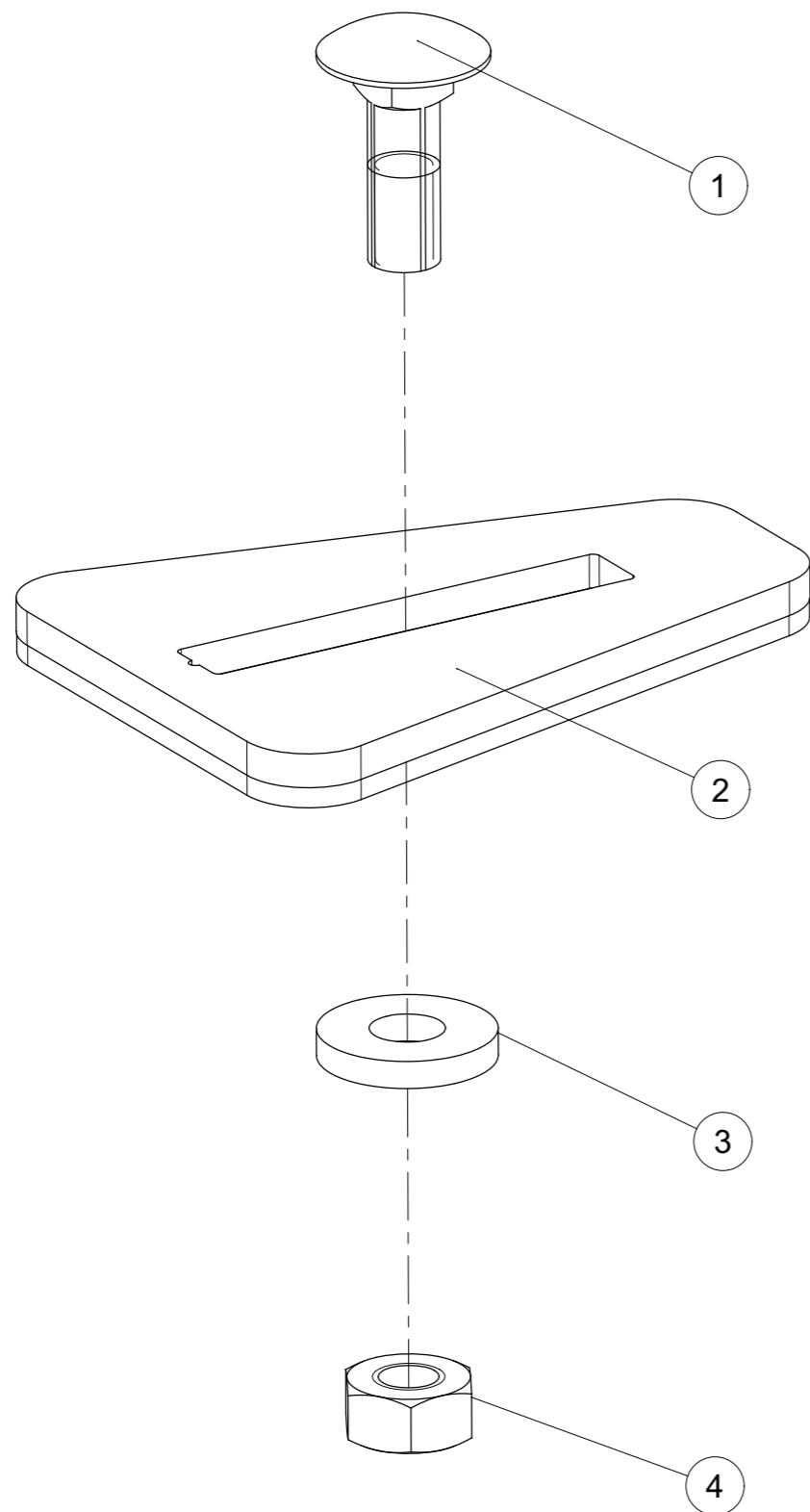

gedeferte Abstuetzung 4 Federn

Pos. / Index	Stck. / Qty	Artikel-Nr.	Benennung / Designation
1	4	931D1255PA	Hex. Schraube M12 x 55 Verzinkt 8.8 Hex. Screw M12 x 55 Zinc 8.8
2	4	931D1650PA	Hex. Schraube M16 x 50 Verzinkt 8.8 Hex. Screw M16 x 50 Zinc 8.8
3	2	933D20240PA	hex. Schraube M20x240 ISO4017-8.8 verzinkt Hex. Screw M20x240 ISO4017-8.8 Zinc
4	4	980DV12PA	Sicherungsmutter M12 Verzinkt 8.8 Nut M12 Zinc 8.8
5	4	980DV16PA	Sicherungsmutter M16 Verzinkt 8.8 Nut M16 Zinc 8.8
6	2	6329.00.01	Spindellager LB-53
7	4	8404.01.31	Zugfeder CF-288
8	2	8411.88.01	Distanzrohr
9	1	8411.88.10	Federaufhängung li. gs.
10	1	8411.88.11	Federaufhängung re. gs.
11	2	8413.63.00	Federhalter gs.
12	2	8413.65.00	Federspanner

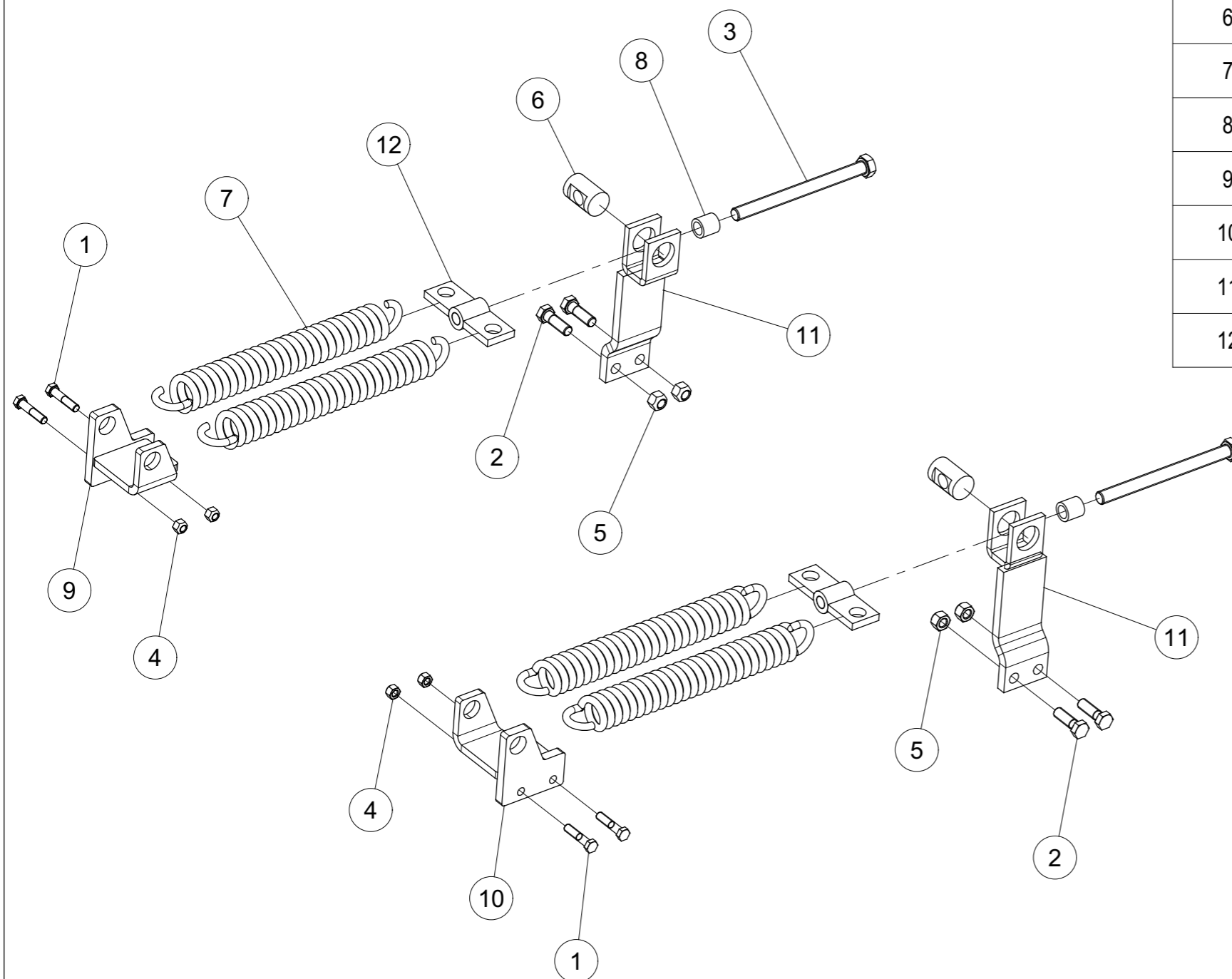

Abstellstuetze kpl.

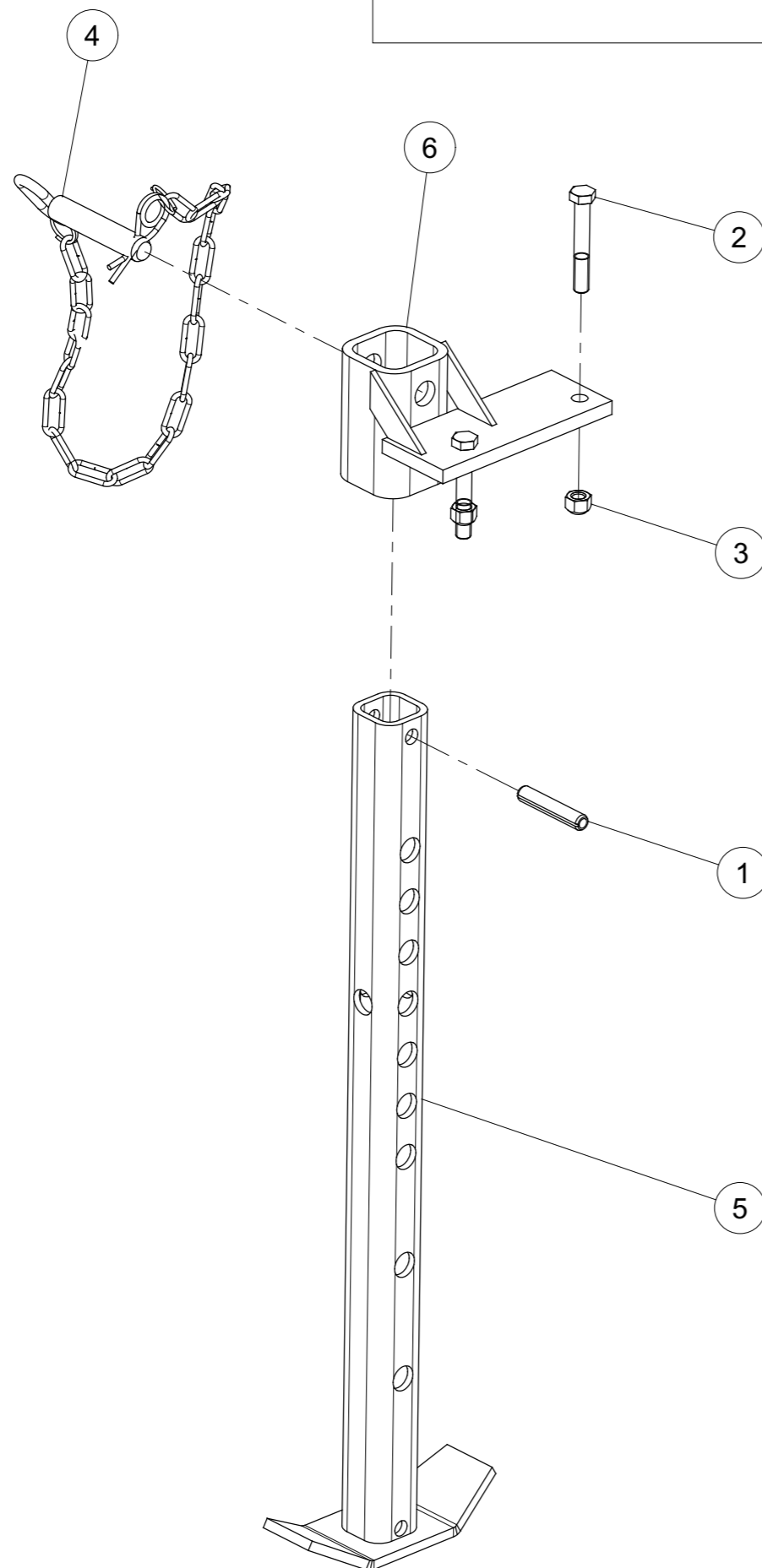

Pos. / Index	Stck. / Qty	Artikel-Nr.	Benennung / Designation
1	1	1481D1370	SPANNSTIFT 13 X 70 ISO8752 Spring Pin 13 X 70 ISO8752
2	2	931D1280NA	Hex. Schraube M12 x 80 Verzinkt 10.9 Hex. Screw M12 x 80 Zinc 10.9
3	2	980DV12NA	Sicherungsmutter M12 Verzinkt 10.9 Nut M12 Zinc 10.9
4	1	7212.05.03	Steckstock verzinkt montiert
5	1	8431.31.01	Abstellstuetze gs.
6	1	8437.66.05	Stuetzenhalter gs.

Turmabstützung PKE 3.0m

Pos. / Index	Stck. / Qty	Artikel-Nr.	Benennung / Designation
1	4	1441D17A	SCHEIBE 17 DIN1441 Z
2	1	8437.93.01	Turmabstützung links 3.0m geschweißt
3	1	8437.93.02	Turmabstützung rechts 3.0m geschweißt
4	4	931D1260NA	Hex. Schraube M12 x 60 Verzinkt 10.9 Hex. Screw M12 x 60 Zinc 10.9
5	4	931D1275NA	Hex. Schraube M12 x 75 Verzinkt 10.9 Hex. Screw M12 x 75 Zinc 10.9
6	8	960D161545NA	Hex. Schraube M16x1.5x45 Verzinkt
7	8	980DV12NA	Sicherungsmutter M12 Verzinkt 10.9 Nut M12 Zinc 10.9
8	8	980DV1615NA	Sicherungsmutter M16x1.5 Verzinkt 10.9 Nut M16x1.5 Zinc 10.9

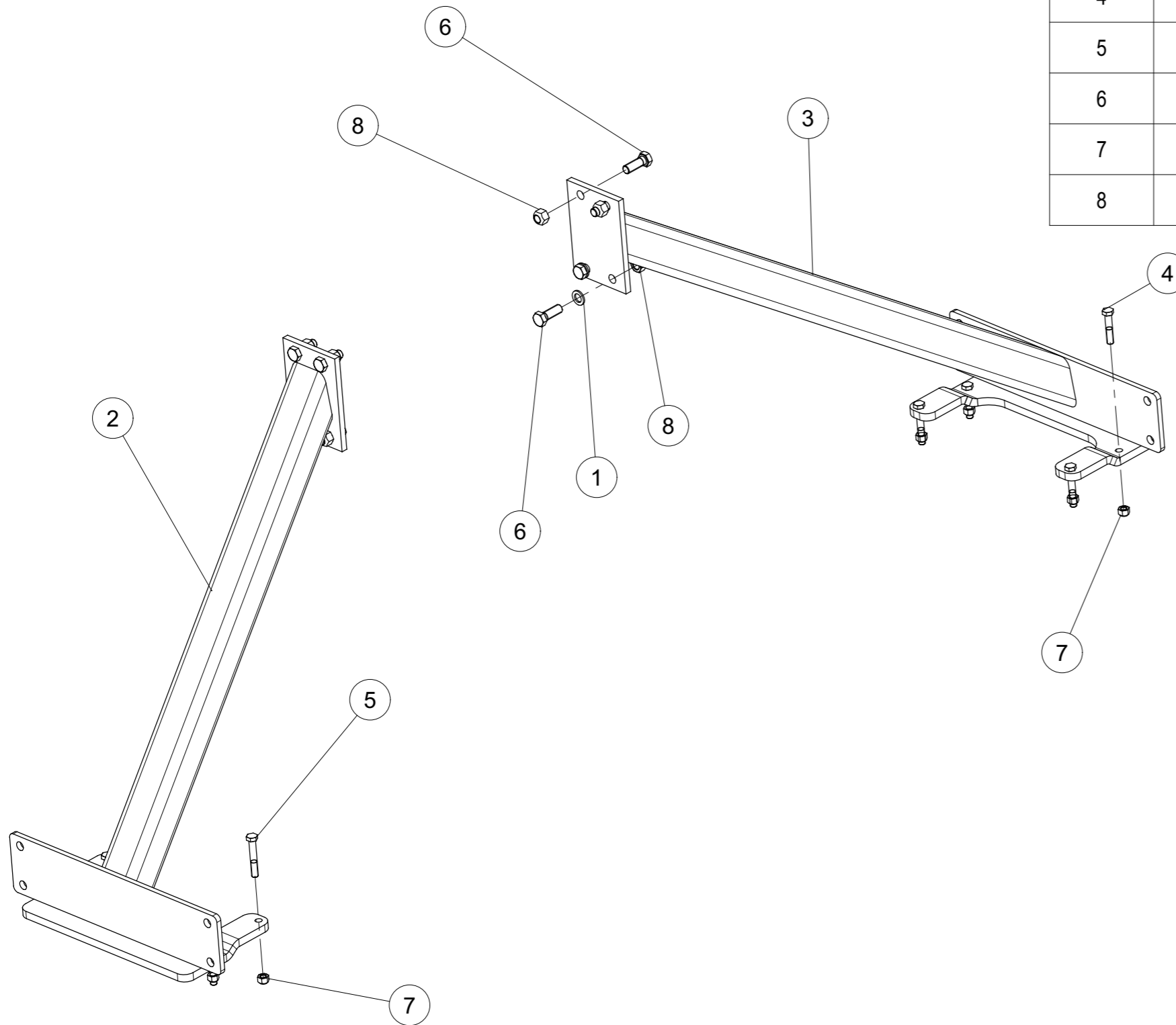

8437.93.50 (1/1)

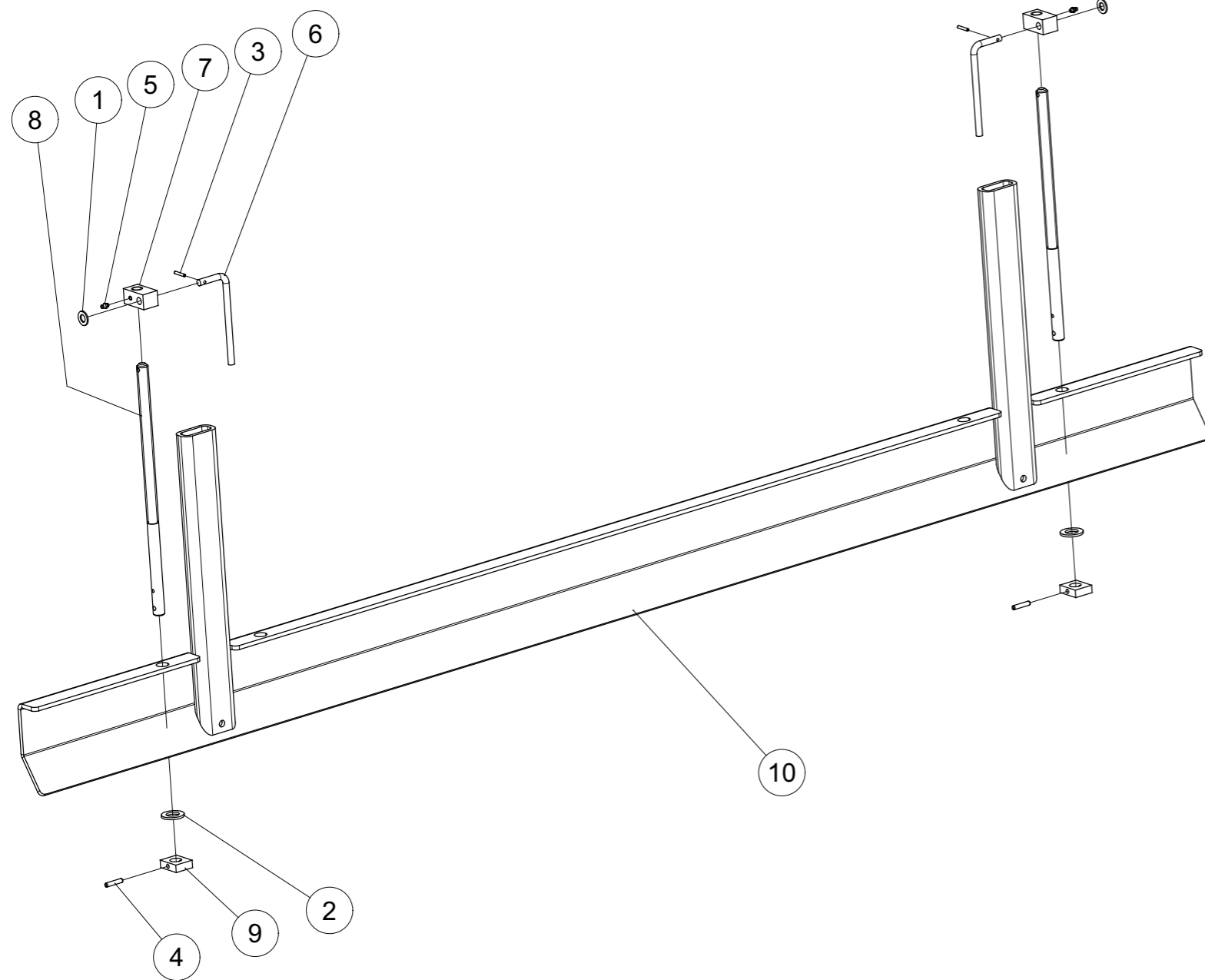

Pos. / Index	Stck. / Qty	Artikel-Nr.	Benennung / Designation
1	2	125DA15A	SCHEIBE A 15 ISO7089 VERZ. Washer A 15 ISO7089 Zinc. Rondelle A 15 ISO7089 Zinguée
2	2	125DA25A	SCHEIBE A 25 ISO7089 VERZ. Washer A 25 ISO7089 Zinc. Rondelle A 25 ISO7089 Zinguée
3	2	1481D530A	SPANNSTIFT 5 X 30 ISO8752 VERZ. Spring Pin 5 X 30 ISO8752 Z Goupille elastique 5 X 30 ISO8752 Z
4	2	1481D840A	SPANNSTIFT 8 X 40 ISO8752 VERZ. Spring Pin 8 X 40 ISO8752 Z Goupille elastique 8 X 40 ISO8752 Z
5	2	71412DA81	SCHMIERNIPPEL H1-M 8x1 -180 Grease Nipple H1-M 8x1 -180 Graisseur H1-M 8x1 -180
6	2	8409.00.34	Drehgriff
7	2	8413.54.02	Spindelverstellung
8	2	8437.83.02	Spindel
9	2	8437.83.50	Lasche D22.5
10	1	8437.84.04	Prallschiene 3.0m gs.

Träger für Prallblech PKE xx11 kpl.

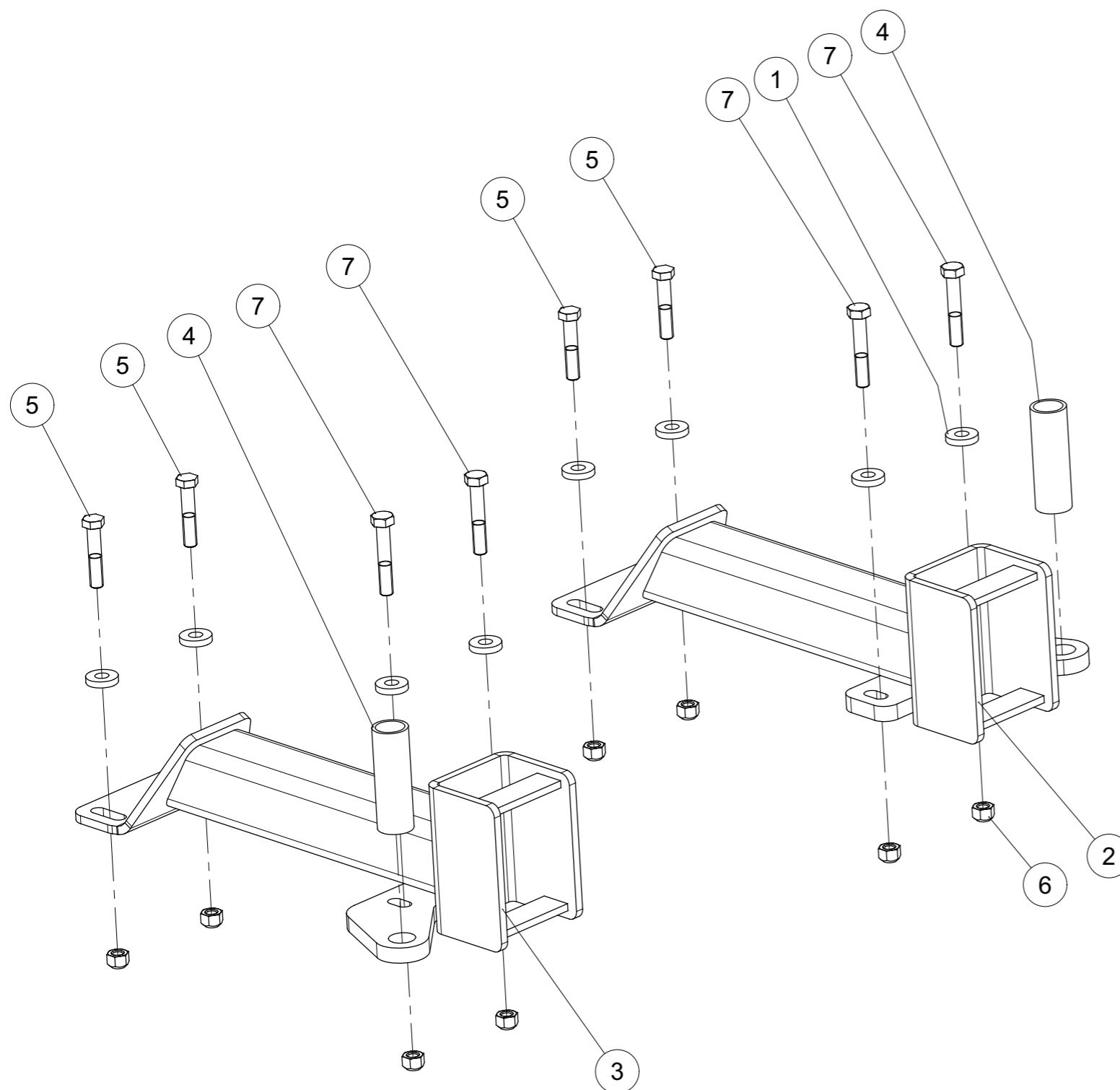

Pos. / Index	Stck. / Qty	Artikel-Nr.	Benennung / Designation
1	8	7349D13A	SCHEIBE 13 DIN7349 verzinkt
2	1	8438.25.01	Traeger fuer Prallblech re.
3	1	8438.25.02	Traeger fuer Prallblech li.
4	2	8447.00.45	SR1ZOLLX100
5	4	931D1260PA	Hex. Schraube M12 x 60 Verzinkt 8.8 Hex. Screw M12 x 60 Zinc 8.8 Vis H M12 x 60 ZNBL 8.8
6	8	980DV12PA	Sicherungsmutter M12 Verzinkt 8.8 Nut M12 Zinc 8.8 Ecrou M12 ZNBL 8.8
7	4	VI 29 16	Schraube H M12x 70 - 8.8 ZNBL Screw H M12x 70 - 8.8 ZNBL Vis H M12x 70 - 8.8 ZNBL

Radspurlockerer starr 80ER Rohr kpl.

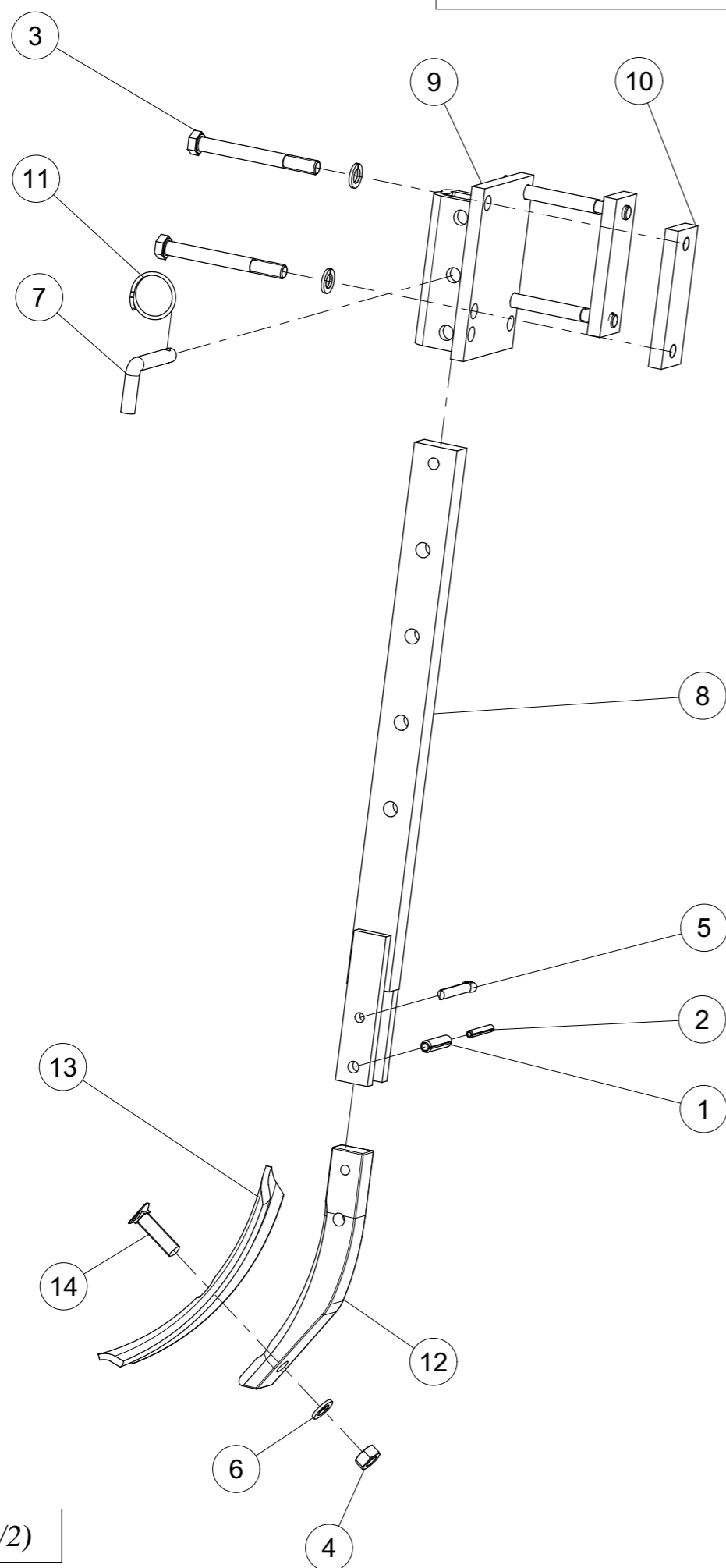

Pos. / Index	Stck. / Qty	Artikel-Nr.	Benennung / Designation
1	1	1481D1045	SPANNSTIFT 10 X 45 ISO8752 Spring Pin 10 X 45 ISO8752 Goupille elastique 10 X 45 ISO8752
2	1	1481D645A	SPANNSTIFT 6 X 45 ISO8752 VERZ. Spring Pin 6 X 45 ISO8752 Z Goupille elastique 6 X 45 ISO8752 Z
3	4	931D12110PA	Hex. Schraube M12 x 110 Verzinkt 8.8 Hex. Screw M12 x 110 Zinc 8.8 Vis H M12 x 110 ZNBL 8.8
4	1	934D12PA	Mutter std H M12 Verzinkt 8.8 Nut std H M12 - thread 175 Zingue Ecrou std H M12 - pas 175 Zingue
5	1	94D850	SPLINT 8x 50 ISO1234 cotter pin 8x 50 ISO1234 Goupille fendue 8x 50 ISO1234
6	5	127DA12A	FEDERRING A 12 DIN127 Z
7	1	6241.29.02	Steckstock TB-12x50
8	1	6241.31.00	Stiel
9	1	6241.39.00	Halter
10	2	6241.94.02	Gewindelasche
11	1	6608.12.07	Sicherungsring
12	1	8007.24.04	Zinkenvorderteil
13	1	8007.30.01	Schar zum Federzinken GG-5
14	1	8007.30.02	Sondersensschraube SSS-12x48

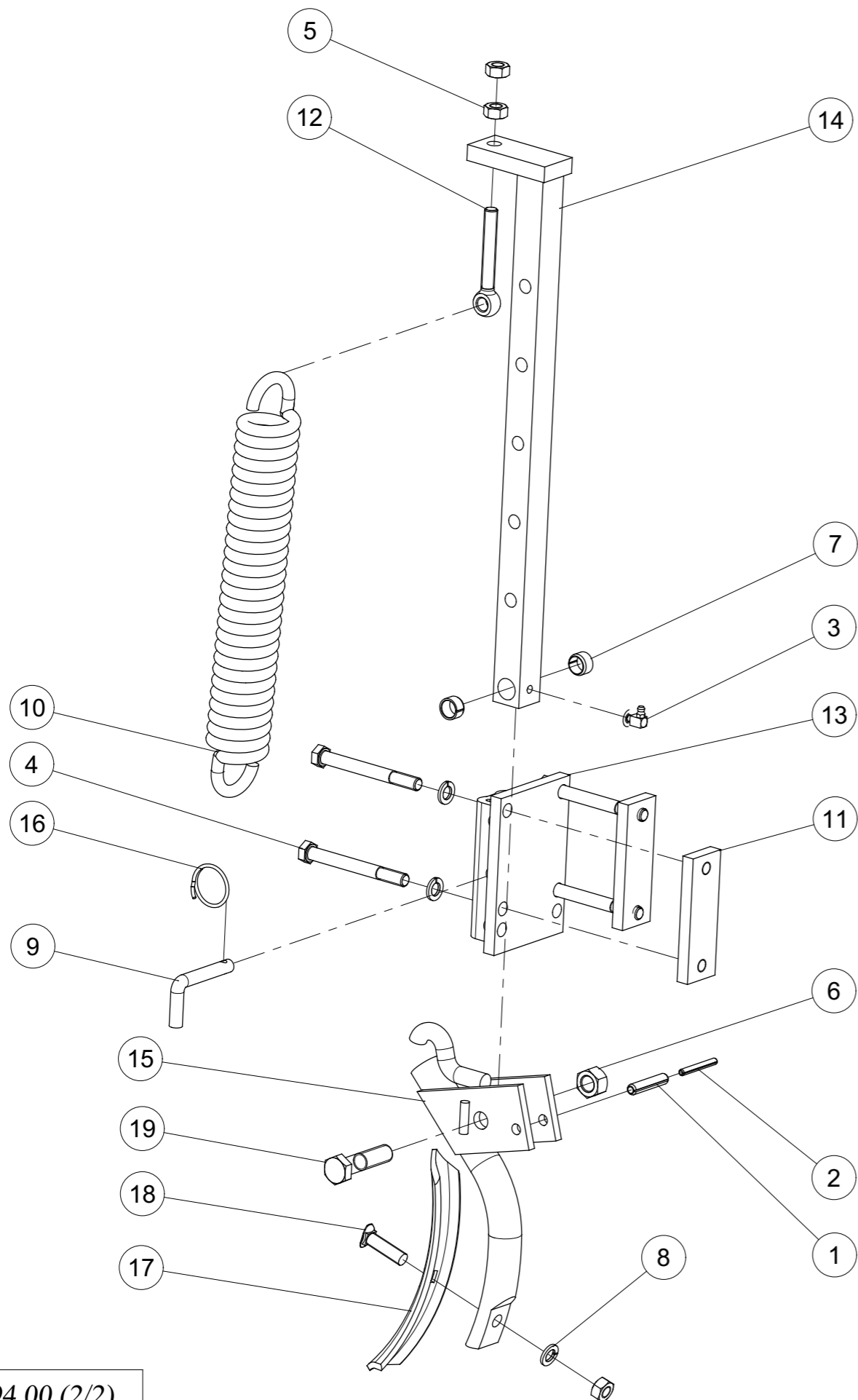

Pos. / Index	Stck. / Qty	Artikel-Nr.	Benennung / Designation
1	1	1481D1050	SPANNSTIFT 10 X 50 ISO8752 Spring Pin 10 X 50 ISO8752 Goupille elastique 10 X 50 ISO8752
2	1	1481D650	SPANNSTIFT 6 X 50 ISO8752 Spring Pin 6 X 50 ISO8752 Goupille elastique 6 X 50 ISO8752
3	1	71412DCS81	SCHMIERNIPPEL H3a-M 8x1 -90 Grease Nipple H3a-M 8x1 -90 Graisseur H3a-M 8x1 -90
4	4	931D12110PA	Hex. Schraube M12 x 110 Verzinkt 8.8 Hex. Screw M12 x 110 Zinc 8.8 Vis H M12 x 110 ZNBL 8.8
5	3	934D12PA	Mutter std H M12 Verzinkt 8.8 Nut std H M12 - thread 175 Zingue Ecrou std H M12 - pas 175 Zingue
6	1	980DV1615PA	Sicherungsmutter M16x1.5 Verzinkt 8.8 Nut M16x1.5 Zinc 8.8 Ecrou M16x1.5 ZNBL 8.8
7	2	1498D162012	BUCHSE EG 16/20x12 DIN1498
8	5	127DA12A	FEDERRING A 12 DIN127 Z
9	1	6241.29.02	Steckstock TB-12x50
10	1	6241.94.01	Zugfeder CF-287
11	2	6241.94.02	Gewindelasche
12	1	6241.94.04	Augenschraube M12X90
13	1	6241.95.00	Tasche
14	1	6241.96.00	Stiel kpl.
15	1	6241.97.00	Zinken kpl.
16	1	6608.12.07	Sicherungsring
17	1	8007.30.01	Schar zum Federzinken GG-5
18	1	8007.30.02	Sondersenkschraube SSS-12x48
19	1	960D161565M	Hex. Schraube M16x1.5x65 Blank Hex. Screw M16x1.5x65 Black Vis hex. M16x1.5x65 noire

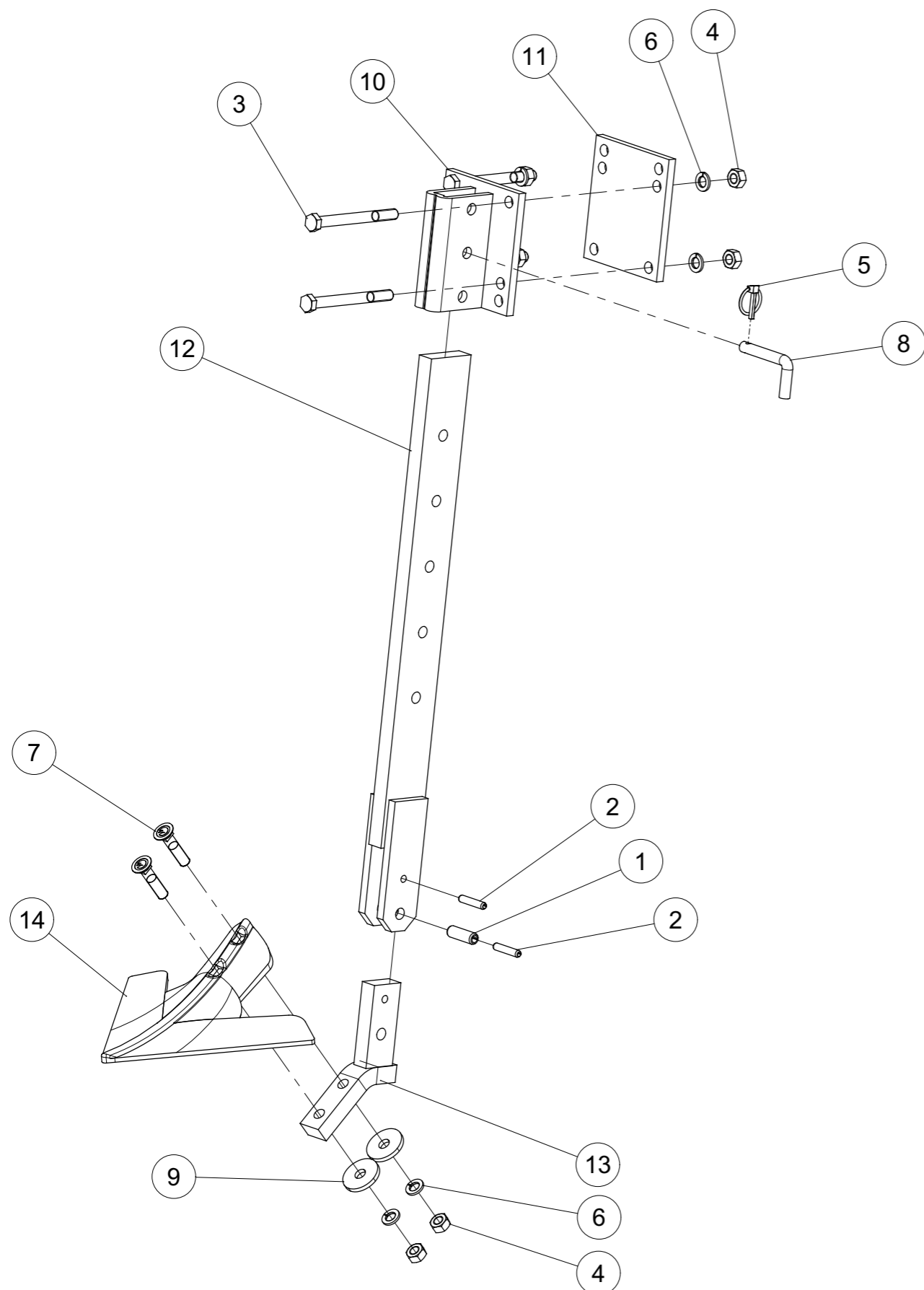

Pos. / Index	Stck. / Qty	Artikel-Nr.	Benennung / Designation
1	1	1481D1340A	SPANNSTIFT 13 X 40 ISO8752 VERZ. Spring Pin 13 X 40 ISO8752 Z Goupille elastique 13 X 40 ISO8752 Z
2	2	1481D840A	SPANNSTIFT 8 X 40 ISO8752 VERZ. Spring Pin 8 X 40 ISO8752 Z Goupille elastique 8 X 40 ISO8752 Z
3	4	931D12120PA	Hex. Schraube M12 x 120 Verzinkt 8.8 Hex. Screw M12 x 120 Zinc 8.8 Vis H M12 x 120 ZNBL 8.8
4	6	934D12PA	Mutter std H M12 Verzinkt 8.8 Nut std H M12 - thread 175 Zingue Ecrou std H M12 - pas 175 Zingue
5	1	11023D532A	KLAPPSTECKER 5x32 DIN11023 Z Lynch pin Dia5
6	6	127DA12A	FEDERRING A 12 DIN127 Z
7	2	2700.26.10	SENKSCHR.M 12 X 55-10.9 VIERK.
8	1	6241.29.02	Steckstock TB-12x50
9	2	6436.60.03	Scheibe C-13
10	1	8409.67.00	Halter
11	1	8409.67.01	Platte
12	1	8409.68.00	Stiel
13	1	8426.32.00	Scharträger
14	1	8426.33.01	Gaensefuß-Schar verg.

Radspurlockerer Ramat mont.

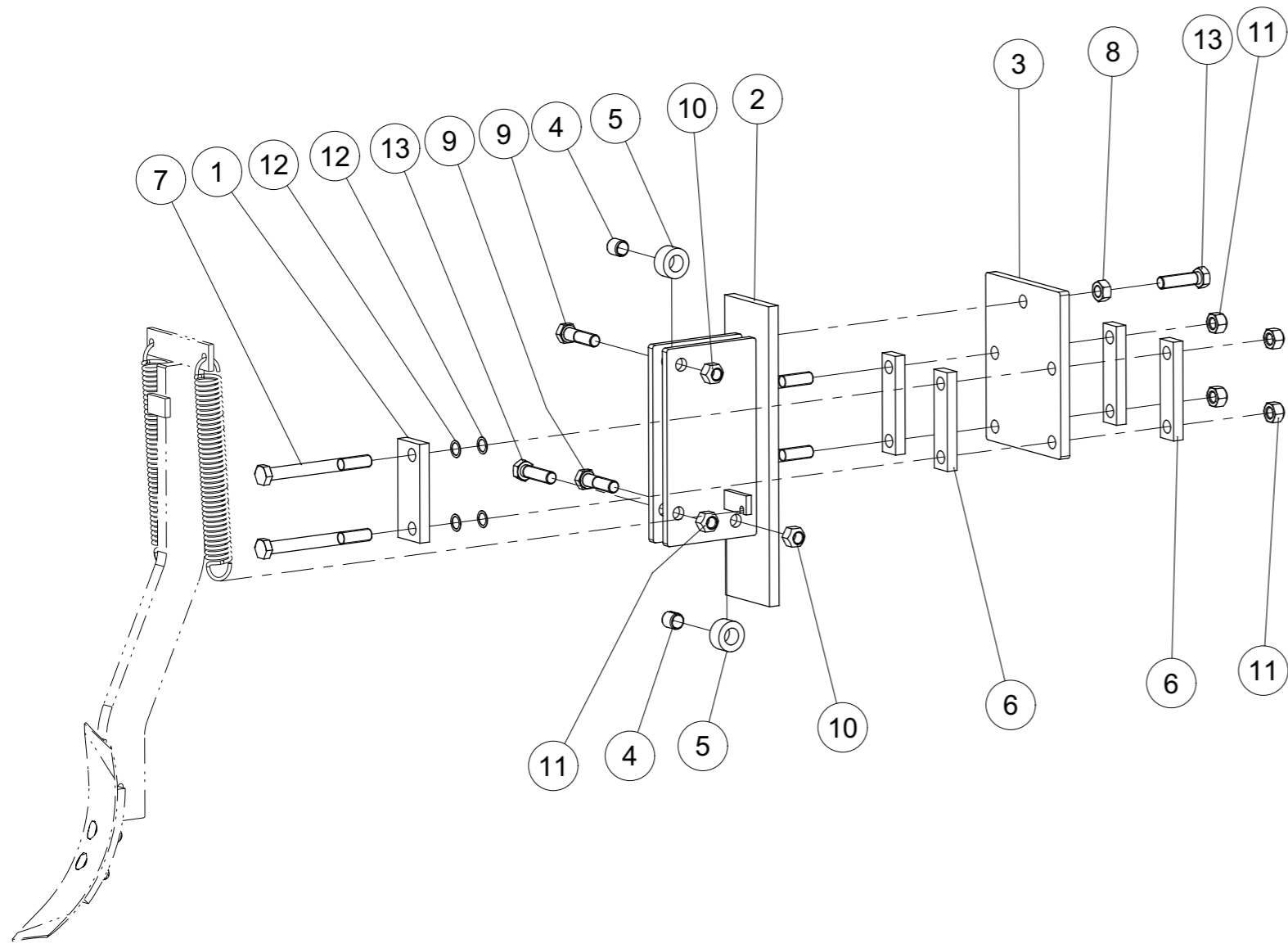

Pos. / Index	Stck. / Qty	Artikel-Nr.	Benennung / Designation
1	2	7305.00.02	Lasche D17-97
2	1	7305.01.01	Fuehrungstasche
3	1	7305.02.01	Verstellplatte
4	2	7346D2122	SPANNSTIFT 21x22 DIN7346
5	2	8416.39.02	Rolle
6	4	8416.39.03	Lasche D17 - 97 (LC-17 x 97)
7	4	931D16160PA	Hex. Schraube M16 x 160 Verzinkt 8.8 Hex. Screw M16 x 160 Zinc 8.8 Vis H M16 x 160 ZNBL 8.8
8	1	934D16PA	Mutter std H M16 Verzinkt 8.8 Nut std H M16 - thread 200 Zingue Ecrou std H M16 - pas 200 Zingue
9	2	960D161560M	Hex. Schraube M16x1.5x60 Blank Hex. Screw M16x1.5x60 Black Vis hex. M16x1.5x60 noire
10	2	980DV1615PA	Sicherungsmutter M16x1.5 Verzinkt 8.8 Nut M16x1.5 Zinc 8.8 Ecrou M16x1.5 ZNBL 8.8
11	5	980DV16PA	Sicherungsmutter M16 Verzinkt 8.8 Nut M16 Zinc 8.8 Ecrou M16 ZNBL 8.8
12	8	988D16220.5	PASSSCHEIBEN 16x 22x0,5 DIN988
13	2	VI 28 30	Schraube H M16x 60 - 8.8 ZNBL ISO4017 Screw H M16x 60 - 8.8 ZNBL ISO4017 Vis H M16x 60 - 8.8 ZNBL ISO4017

Pos. / Index	Stck. / Qty	Artikel-Nr.	Benennung / Designation
1	2	127DA12A	FEDERING A 12 DIN127 Z
2	1	7305.03.01	Spurlockererzinken verg. geschw.
3	2	8007.30.02	Sondersenkschraube SSS-12x48
4	1	8406.41.01	Schar GG-60
5	2	8409.00.35	Zugfeder CF-244
6	2	934D12PA	Mutter std H M12 Verzinkt 8.8 Nut std H M12 - thread 175 Zingue Ecrou std H M12 - pas 175 Zingue

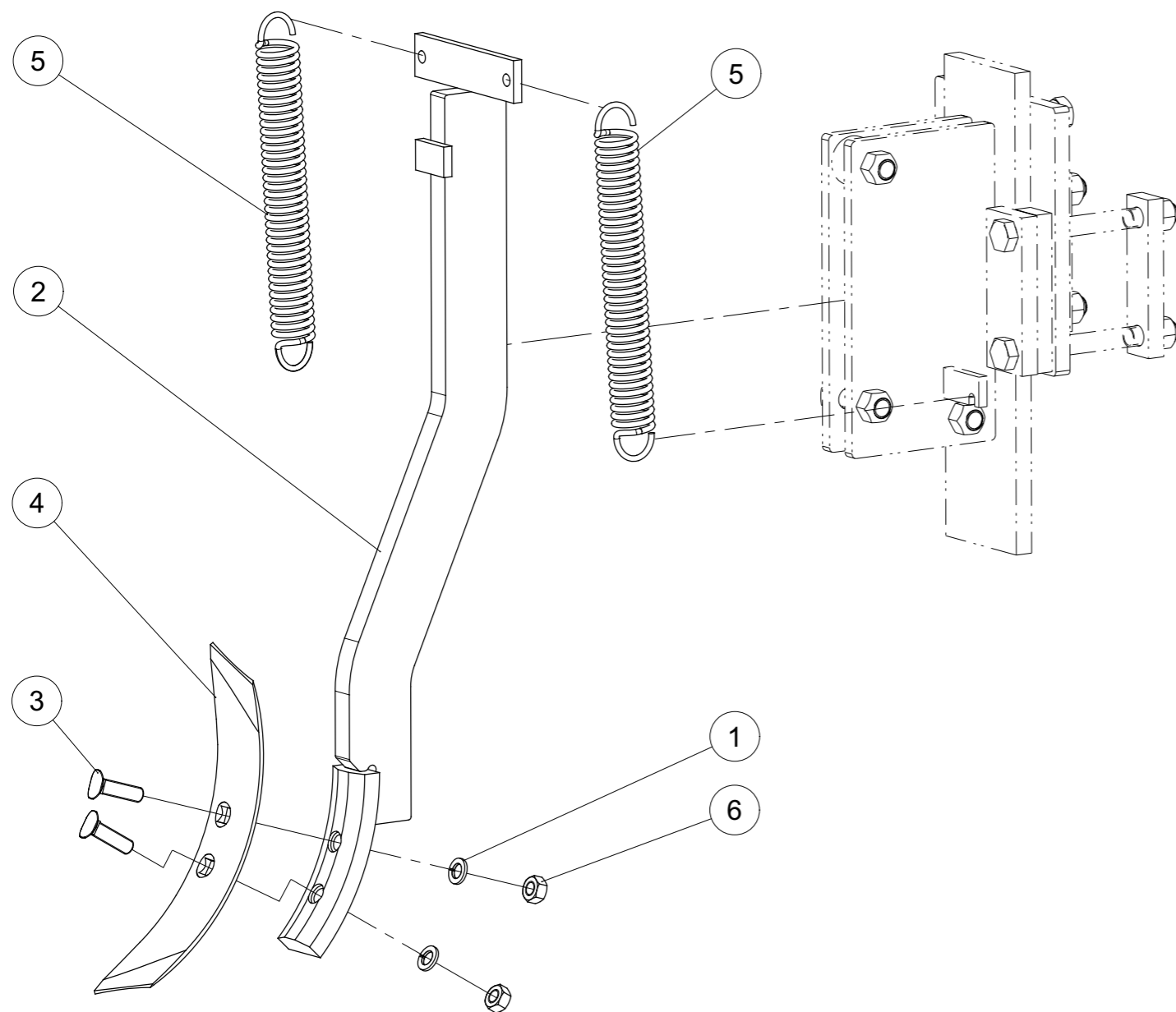

Segmenten-Schutzschiene hinten 3.0m kpl.

Pos. / Index	Stck. / Qty	Artikel-Nr.	Benennung / Designation
1	9	931D1260NA	Hex. Schraube M12 x 60 Verzinkt 10.9 Hex. Screw M12 x 60 Zinc 10.9 Vis H M12 x 60 ZNBL 10.9
2	9	931D1275NA	Hex. Schraube M12 x 75 Verzinkt 10.9 Hex. Screw M12 x 75 Zinc 10.9 Vis H M12 x 75 ZNBL 10.9
3	18	980DV12NA	Sicherungsmutter M12 Verzinkt 10.9 Nut M12 Zinc 10.9 Ecrou M12 ZNBL 10.9
4	16	6436.60.03	Scheibe C-13
5	2	8435.60.03	Segmentenschutzschiene hi. 3.0m gs.

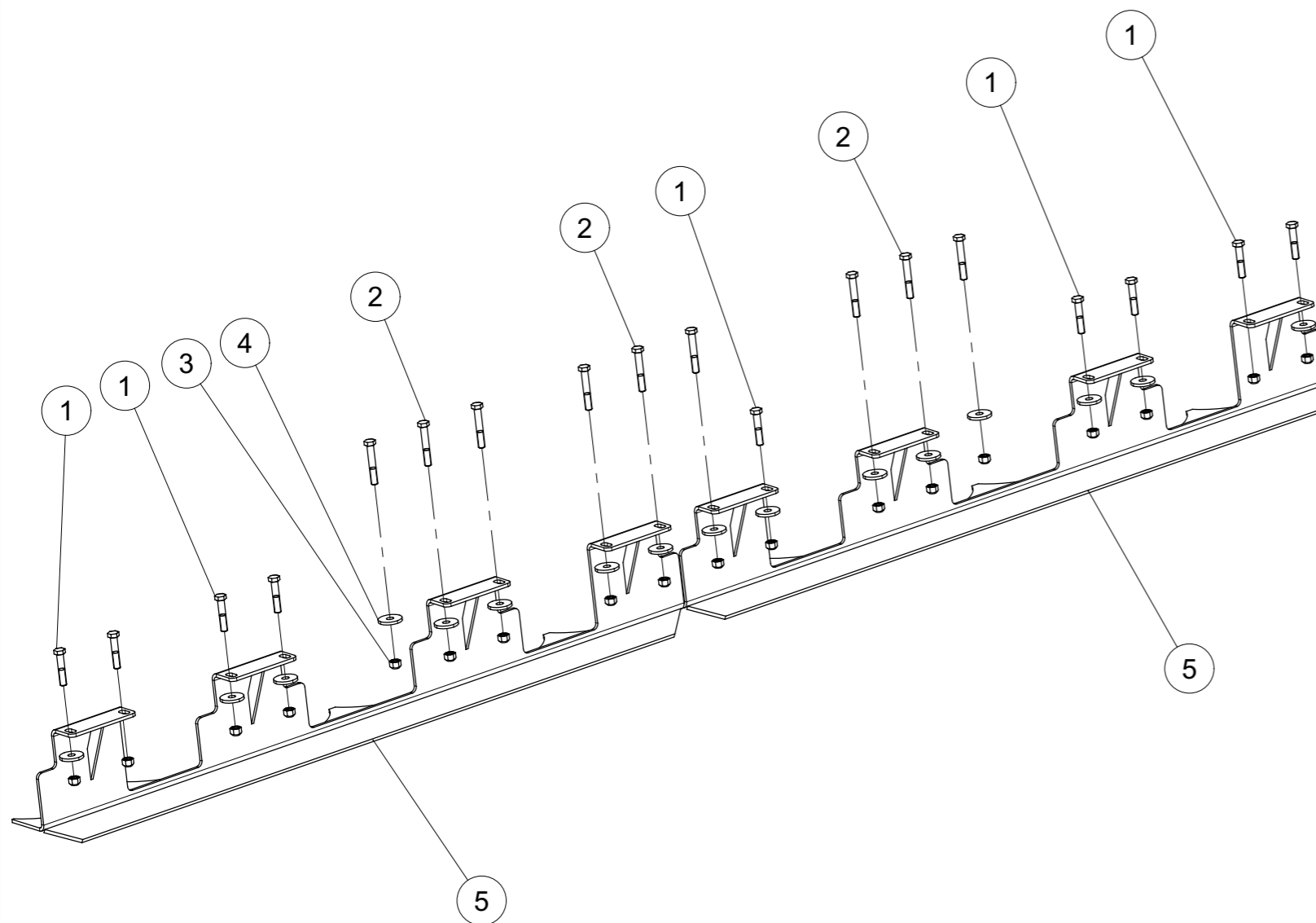

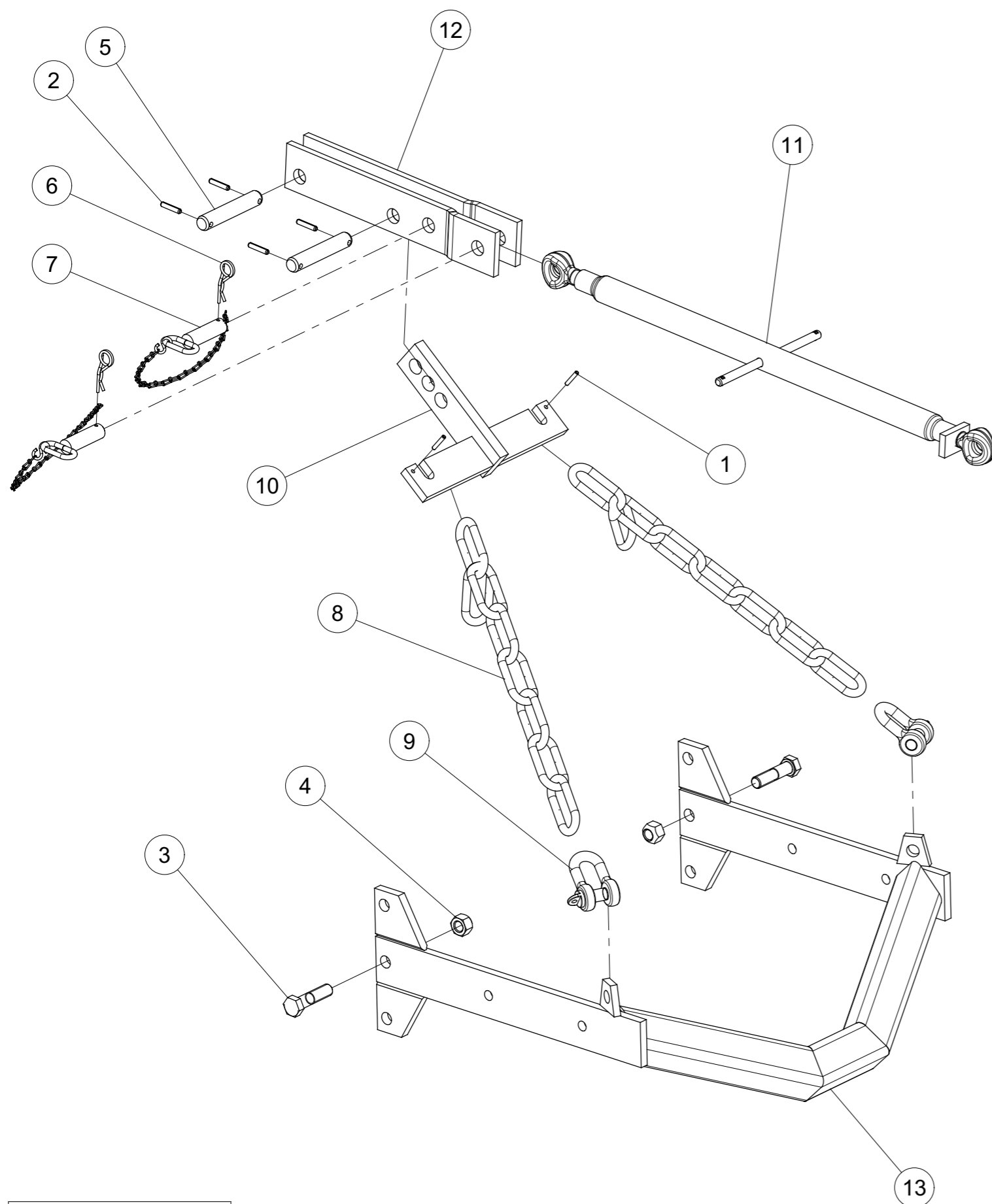

Pos. / Index	Stck. / Qty	Artikel-Nr.	Benennung / Designation
1	2	1481D636A	SPANNSTIFT 6 X 36 ISO8752 VERZ. Spring Pin 6 X 36 ISO8752 Z Goupille elastique 6 X 36 ISO8752 Z
2	4	1481D840A	SPANNSTIFT 8 X 40 ISO8752 VERZ. Spring Pin 8 X 40 ISO8752 Z Goupille elastique 8 X 40 ISO8752 Z
3	2	931D2080PA	Hex. Schraube M20 x 80 Verzinkt 8.8 Hex. Screw M20 x 80 Zinc 8.8 Vis H M20 x 80 ZNBL 8.8
4	2	980DV20PA	Sicherungsmutter M20 Verzinkt 8.8 Nut M20 Zinc 8.8 Ecrou M20 ZNBL 8.8
5	2	1000.25.04	Bolzen D25x120 verz.
6	2	11024D4A	FEDERSTECKER-11024 4 Z DW
7	2	7512.08.00	Steckstock
8	2	763D0_656K13	Kette O.656m-13 DIN763
9	2	82101DA0.4	Schaekel A 1.6 DIN 82101
10	1	8405.40.00	Verstellstück
11	1	8411.34.00	Spannschloß M27 (700-900) verz. mont.
12	1	8413.34.00	Turmanlenkung
13	1	8438.04.01	Grundrahmen

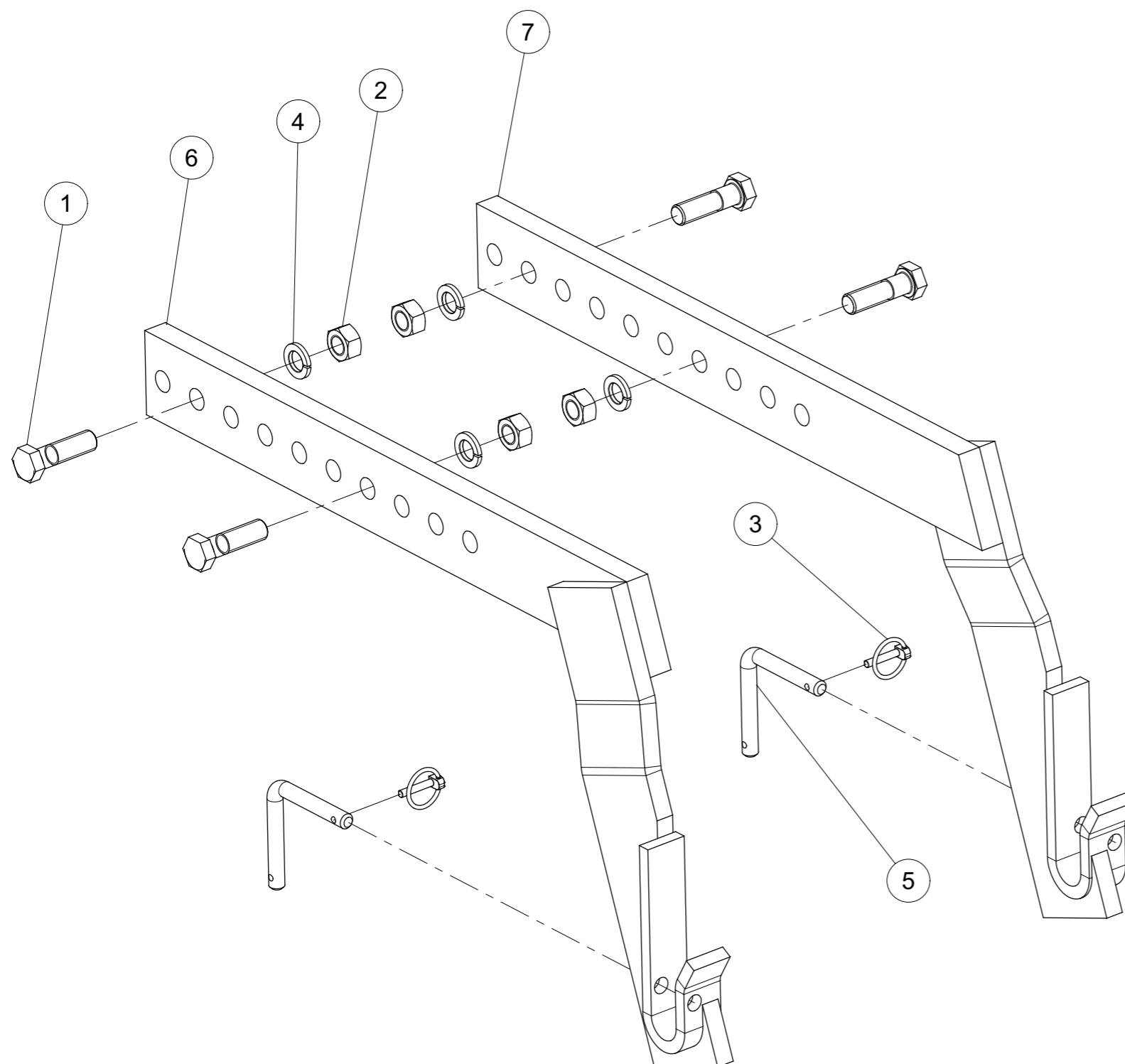

Pos. / Index	Stck. / Qty	Artikel-Nr.	Benennung / Designation
1	4	931D1655NA	Hex. Schraube M16 x 55 Verzinkt 10.9 Hex. Screw M16 x 55 Zinc 10.9
2	4	934D16PA	Mutter std H M16 Verzinkt 8.8 Nut std H M16 - thread 200 Zingue Ecrou std H M16 - pas 200 Zingue
3	2	11023D532A	KLAPPSTECKER 5x32 DIN11023 Z Lynch pin Dia5
4	4	127DB16A	FEDERRING B 16 DIN127 Z
5	2	8405.12.08	Griff
6	1	8405.25.01	Anbauarm links Kat.2 geschweißt
7	1	8405.25.02	Anbauarm rechts Kat.2 geschweißt

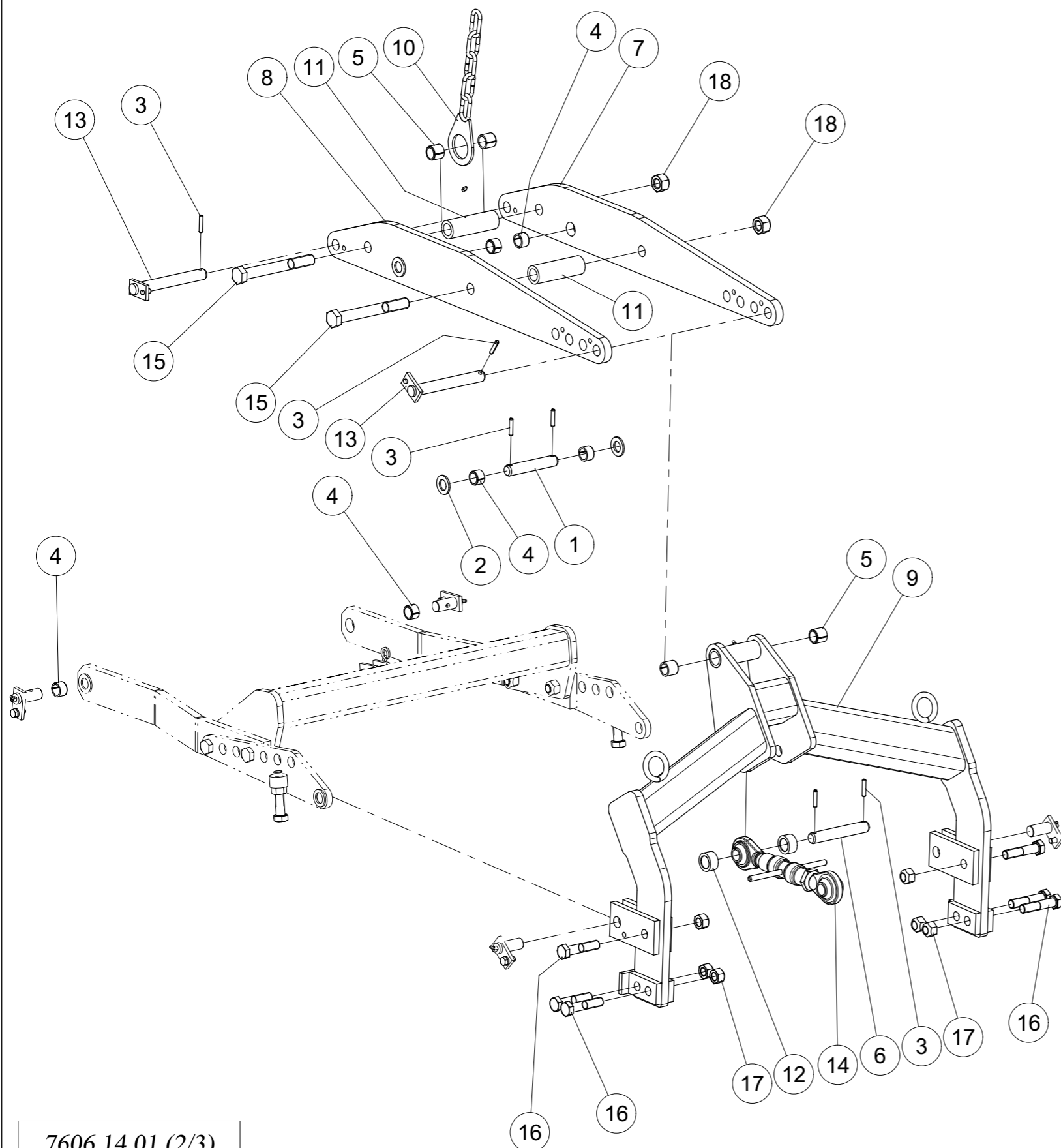

Pos. / Index	Stck. / Qty	Artikel-Nr.	Benennung / Designation
1	1	1000.25.04	Bolzen D25x120 verz.
2	2	125DA25A	SCHEIBE A 25 ISO7089 VERZ. Washer A 25 ISO7089 Zinc. Rondelle A 25 ISO7089 Zinguée
3	6	1481D840A	SPANNSTIFT 8 X 40 ISO8752 VERZ. Spring Pin 8 X 40 ISO8752 Z Goupille elastique 8 X 40 ISO8752 Z
4	6	1498D253220	BUCHSE EG 25/32x20 DIN1498
5	4	1498D253228	BUCHSE EG 25/32x28 DIN1498
6	1	7520.10.01	Bolzen D25-140 verz.
7	1	7606.10.01	Hubarm re.gs.
8	1	7606.10.02	Hubarm li.gs.
9	1	7606.12.01	Hubturm geschw.
10	1	7606.13.02	Sicherungskette gs.
11	2	7606.14.03	Halterohr
12	2	7606.14.04	Buchse
13	2	8405.58.00	Sicherungsbolzen D25-178
14	1	9108.78.01	Oberlenker Kat II, M30x3.5 Kpl. (280-335 mm)
15	2	931D24200PA	Hex. Schraube M24 x 200 Verzinkt 8.8 Hex. Screw M24 x 200 Zinc 8.8 Vis H M24 x 200 ZNBL 8.8
16	6	960D201590NA	Hex. Schraube M20x1.5x90 Verzinkt Hex. Screw M20x1.5x90 ZNBL Vis hex. M20x1.5x90 ZNBL
17	6	980DV2015NA	Sicherungsmutter M20x1.5 Verzinkt 10.9 Nutmutter M20x1.5 Zinc 10.9 Ecrou M20x1.5 ZNBL 10.9
18	2	980DV24PA	Sicherungsmutter M24 Verzinkt 8.8 Nutmutter M24 Zinc 8.8 Ecrou M24 ZNBL 8.8

Drill-Lift Ausführung 1 kpl.

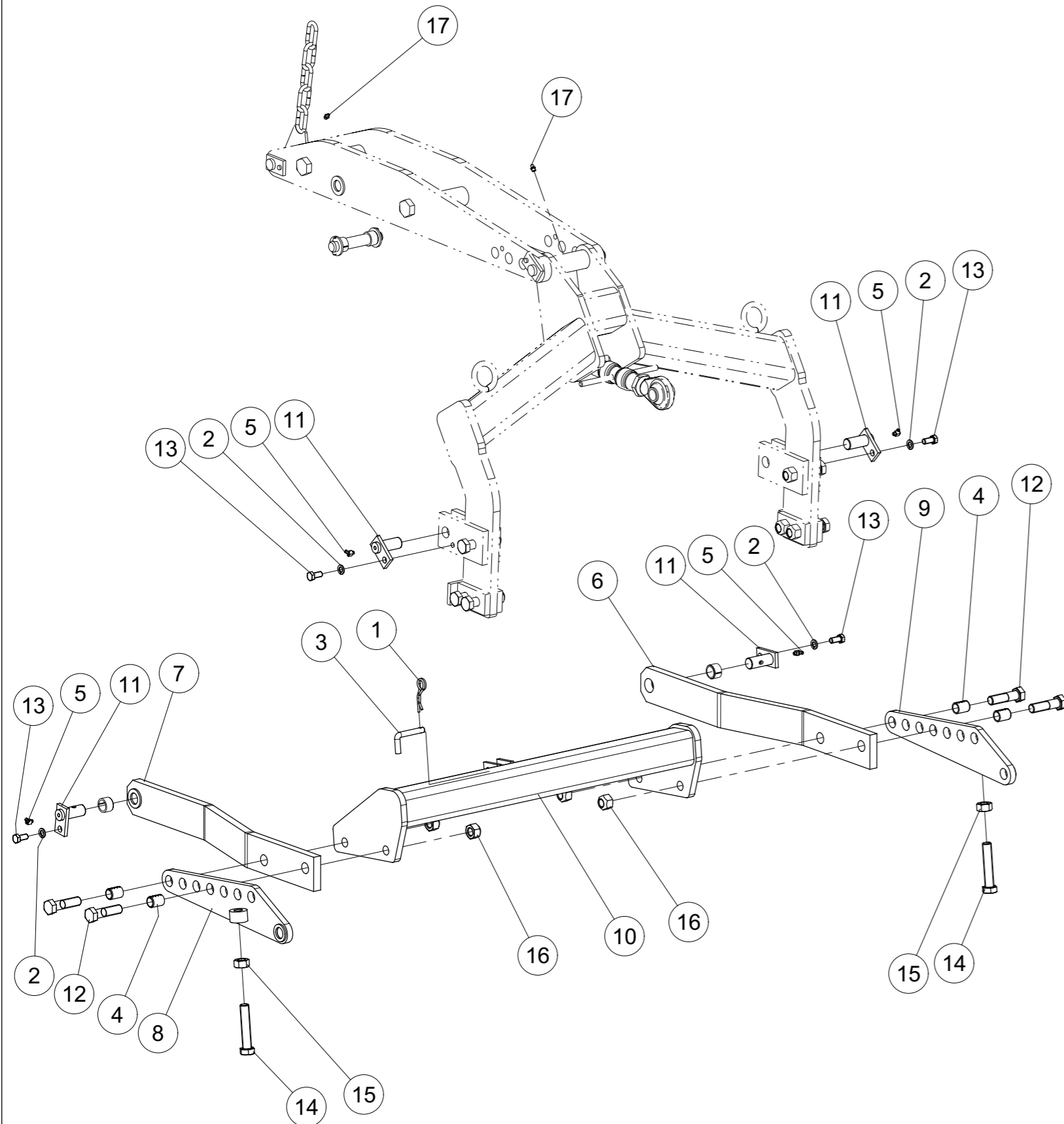

Pos. / Index	Stck. / Qty	Artikel-Nr.	Benennung / Designation
1	1	11024D4A	FEDERSTECKER-11024 4 Z DW
2	4	127DA12A	FEDERRING A 12 DIN127 Z
3	1	6241.29.02	Steckstock TB-12x50 Pin TB-12x50
4	4	7002.05.00	SPANNSTIFT 25 X 20 X 32 MIT WELLENSCHLITZ Steel bushing Ø 25 x 20 x 32 Bagues acier Ø 25 x 20 x 32
5	4	71412DB81	SCHMIERNIPPEL H2-M 8x1 - 45 Grease Nipple H2-M 8x1 - 45 Graisseur H2-M 8x1 - 45
6	1	7606.09.01	Seitenarm re.gs.
7	1	7606.09.02	Seitenarm li.gs.
8	1	7606.15.01	Verstellstück li.gs.
9	1	7606.15.02	Verstellstück re.gs.
10	1	7606.16.01	Querrohr
11	4	8413.38.00	Verstellarmbolzen
12	4	931D2075NA	Hex. Schraube M20 x 75 Verzinkt 10.9 Hex. Screw M20 x 75 Zinc 10.9 Vis H M20 x 75 ZNBL 10.9
13	4	933D1225NA	hex. Schraube M12x25 ISO4017-10.9 verzinkt Hex. Screw M12x25 ISO4017-10.9 Zinc Vis H M12x25 ISO4017-10.9 ZNBL
14	2	933D20100PA	hex. Schraube M20x100 ISO4017-8.8 verzinkt Hex. Screw M20x100 ISO4017-8.8 Zinc Vis H M20x100 ISO4017-8.8 ZNBL
15	2	934D20PA	Mutter std H M20 Verzinkt 8.8 Nut std H M20 - thread 250 Zingue Ecrou std H M20 - pas 250 Zingue
16	4	980DV20NA	Sicherungsmutter M20 Verzinkt 10.9 Nut M20 Zinc 10.9 Ecrou M20 ZNBL 10.9
17	2	VM 214	Gerader schmiernippel - M8 x 100 Grease nipple - M8, thread100 Graisseur droit - M8, pas100

Drill-Lift Ausführung 3 kpl.

Pos. / Index	Stck. / Qty	Artikel-Nr.	Benennung / Designation
1	1	7606.14.01	Drill-Lift Ausführung 1 kpl.
2	1	7606.27.01	Haltetasche li.gs.
3	1	7606.27.02	Haltetasche re.gs.
4	6	8405.00.18	Poly-Stop Sechskantmutter m. Bund
5	4	960D161545NA	Hex. Schraube M16x1.5x45 Verzinkt Hex. Screw M16x1.5x45 ZNBL Vis hex. M16x1.5x45 ZNBL
6	2	960D161560M	Hex. Schraube M16x1.5x60 Blank Hex. Screw M16x1.5x60 Black Vis hex. M16x1.5x60 noire

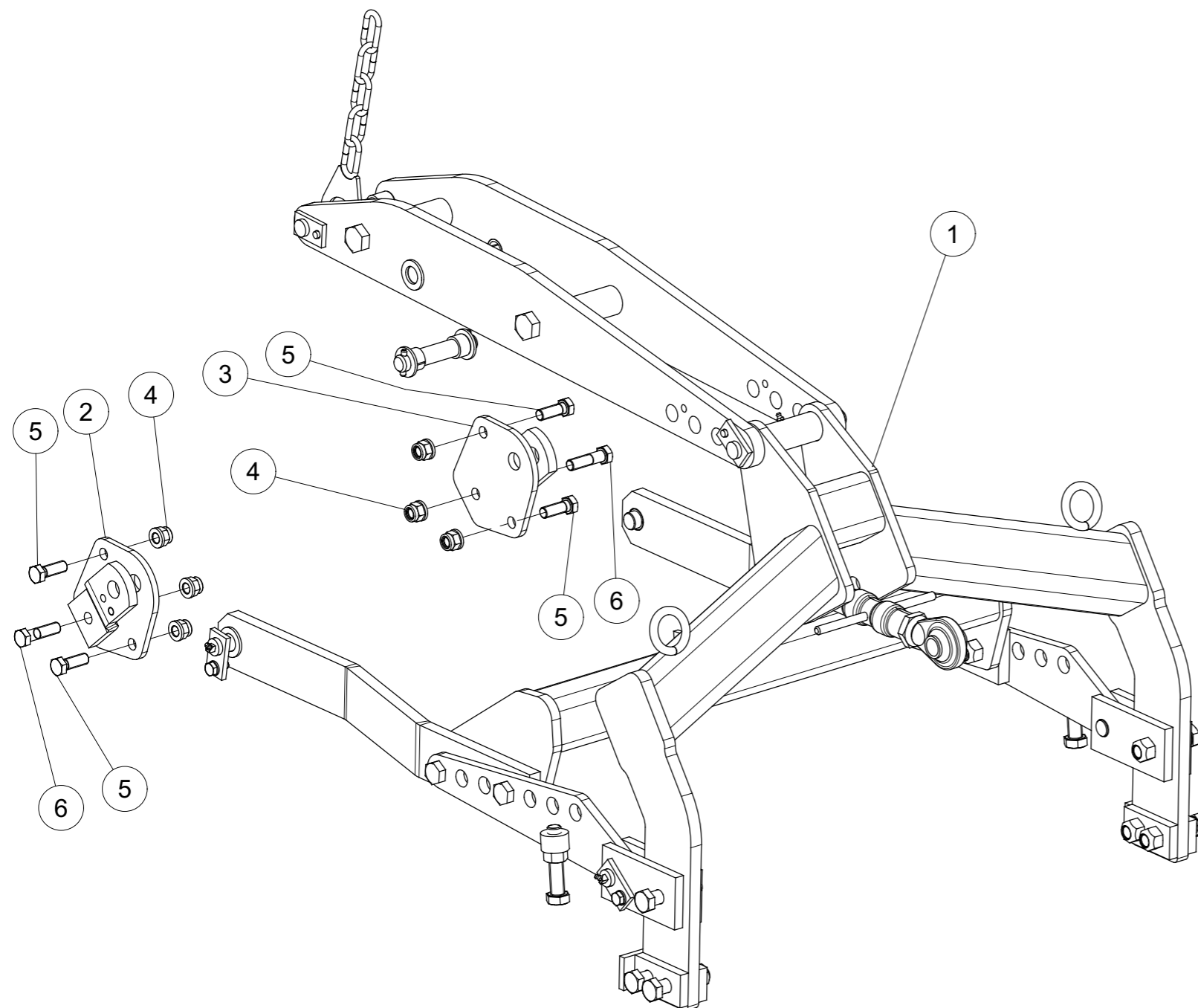

Pos. / Index	Stck. / Qty	Artikel-Nr.	Benennung / Designation
1	2	11023D532A	KLAPPSTECKER 5x32 DIN11023 Z Lynch pin Dia5
2	2	6336.72.01	Riegel Kat. 2
3	1	7606.11.01	Anlenkung Kat.2 rechts geschweißt
4	1	7606.11.02	Anlenkung Kat.2 links geschweißt

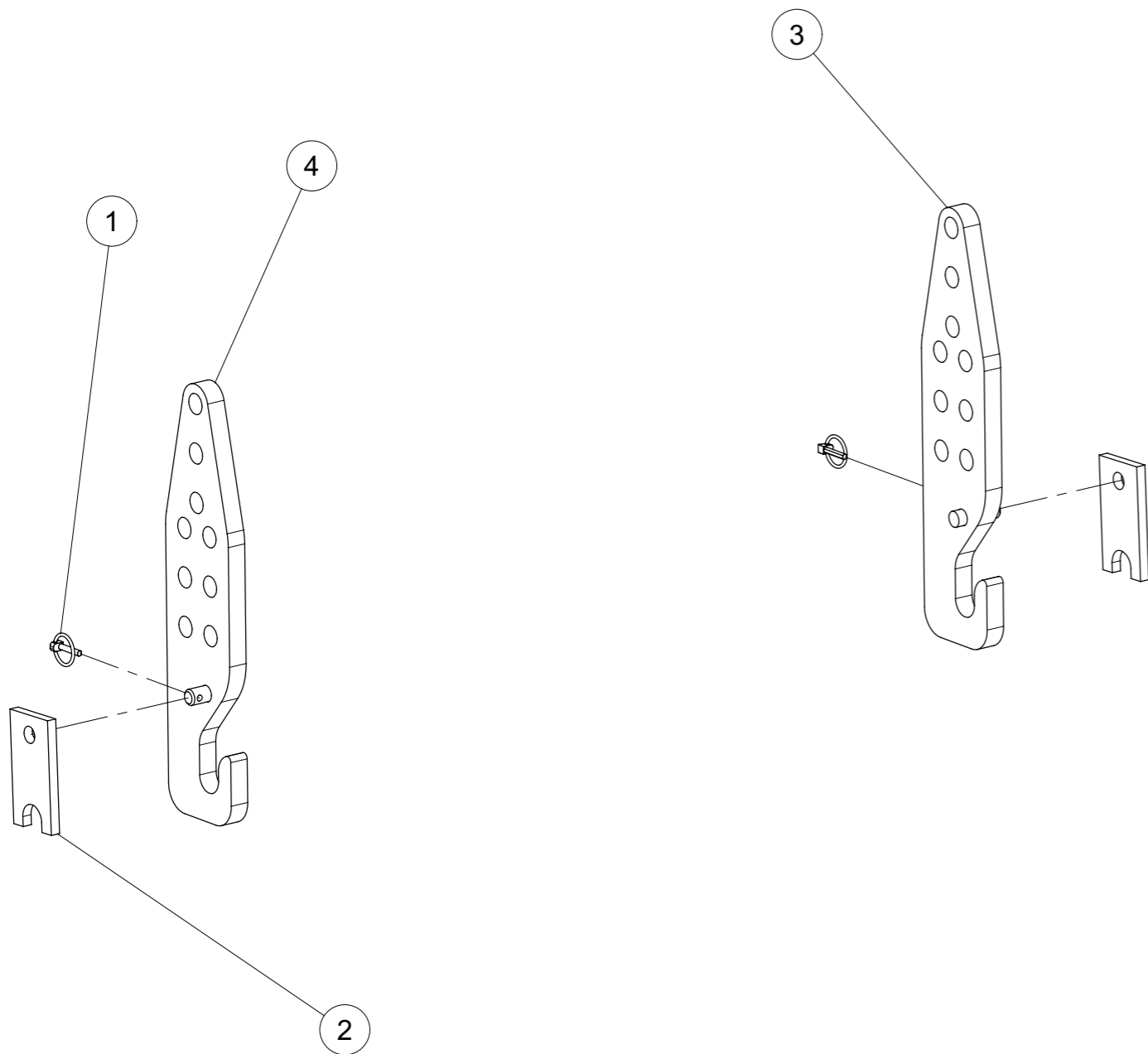

Pos. / Index	Stck. / Qty	Artikel-Nr.	Benennung / Designation
1	2	11023D532A	KLAPPSTECKER 5x32 DIN11023 Z Lynch pin Dia5
2	2	6336.72.02	Riegel Kat.3
3	1	7606.11.03	Anlenkung Kat.3 rechts geschweißt
4	1	7606.11.04	Anlenkung Kat.3 links geschweißt

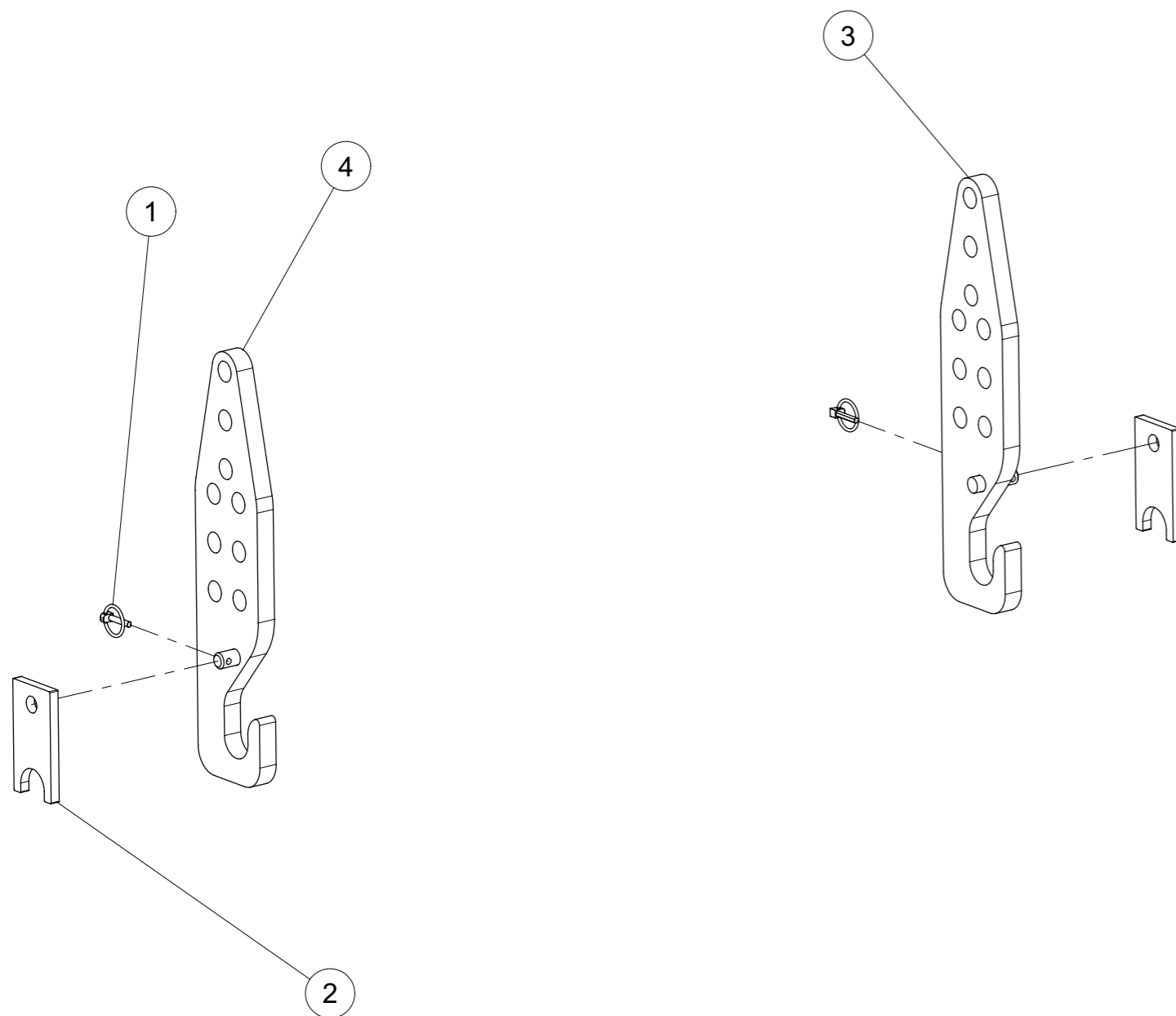

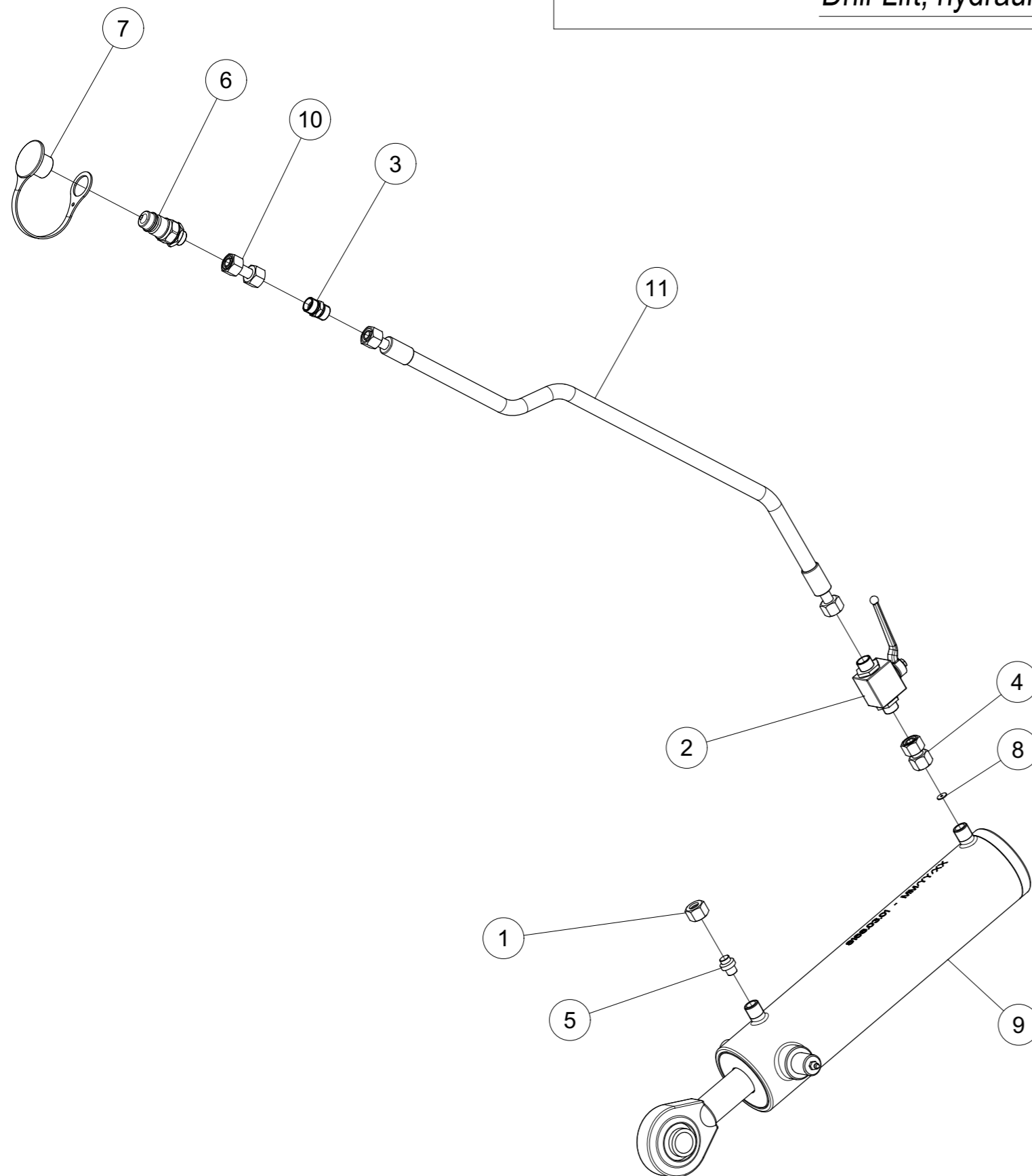

Pos. / Index	Stck. / Qty	Artikel-Nr.	Benennung / Designation
1	1	4716.46.04	Ueberwurfmutter M18x1,5 (F. D12-L)
2	1	4716.46.05	HD-Blockkugelhahn NW10 verz.
3	1	4716.52.13	Gerade Verschraubung G12-L - M18x1,5
4	1	4716.53.05	Doppelmutter DMO NW10L
5	1	6432.58.23	Rohrverschlussbutzen
6	1	8132.01.00	Hydr. Stecker HL3 AG M18x1,5
7	1	8132.05.01	Staubkappe
8	1	8132.06.04	Drosselscheibe \varnothing 2.5
9	1	8168.03.01	Zylinder 80/35/300 Mont.
10	1	8172.02.28	Hydraulikrohr 50 lg. kpl. (NW10)
11	1	8413.88.01	Hydr.Schlauch 2SN DN10 1500 D20022

Drill-Lift, hydraulischer Aushub Doppeltwirkend

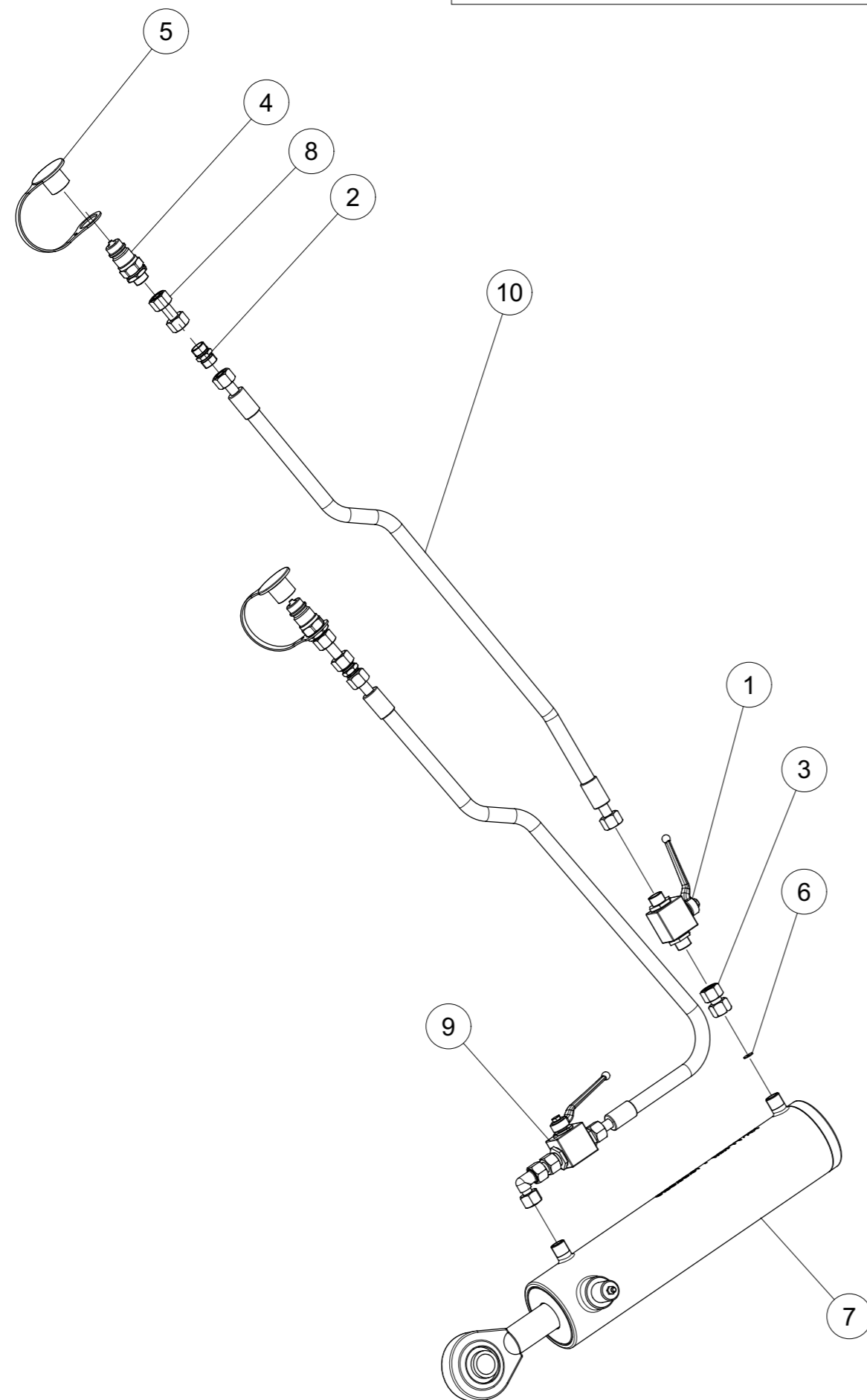

Pos. / Index	Stck. / Qty	Artikel-Nr.	Benennung / Designation
1	1	4716.46.05	HD-Blockkugelhahn DN10
2	1	4716.52.13	Gerade Verschraubung
3	1	4716.53.05	Doppelmutter DMO (40lg)
4	1	8132.01.00	Kupplungsstecker ISO 7241-1 Serie A
5	1	8132.05.01	Staubkappe
6	1	8132.06.04	Drosselscheibe Ø 2.5
7	1	8168.03.01	Zylinder 80/35/300 Mont.
8	1	8172.02.28	Hydraulikrohr 50 lg. kpl.
9	1	8406.83.10	Frontanbau Drill-Lift hyd. Erweiterung
10	1	8413.88.01	Hydr.Schlauch 2SN DN10 1500

Hubbegrenzung

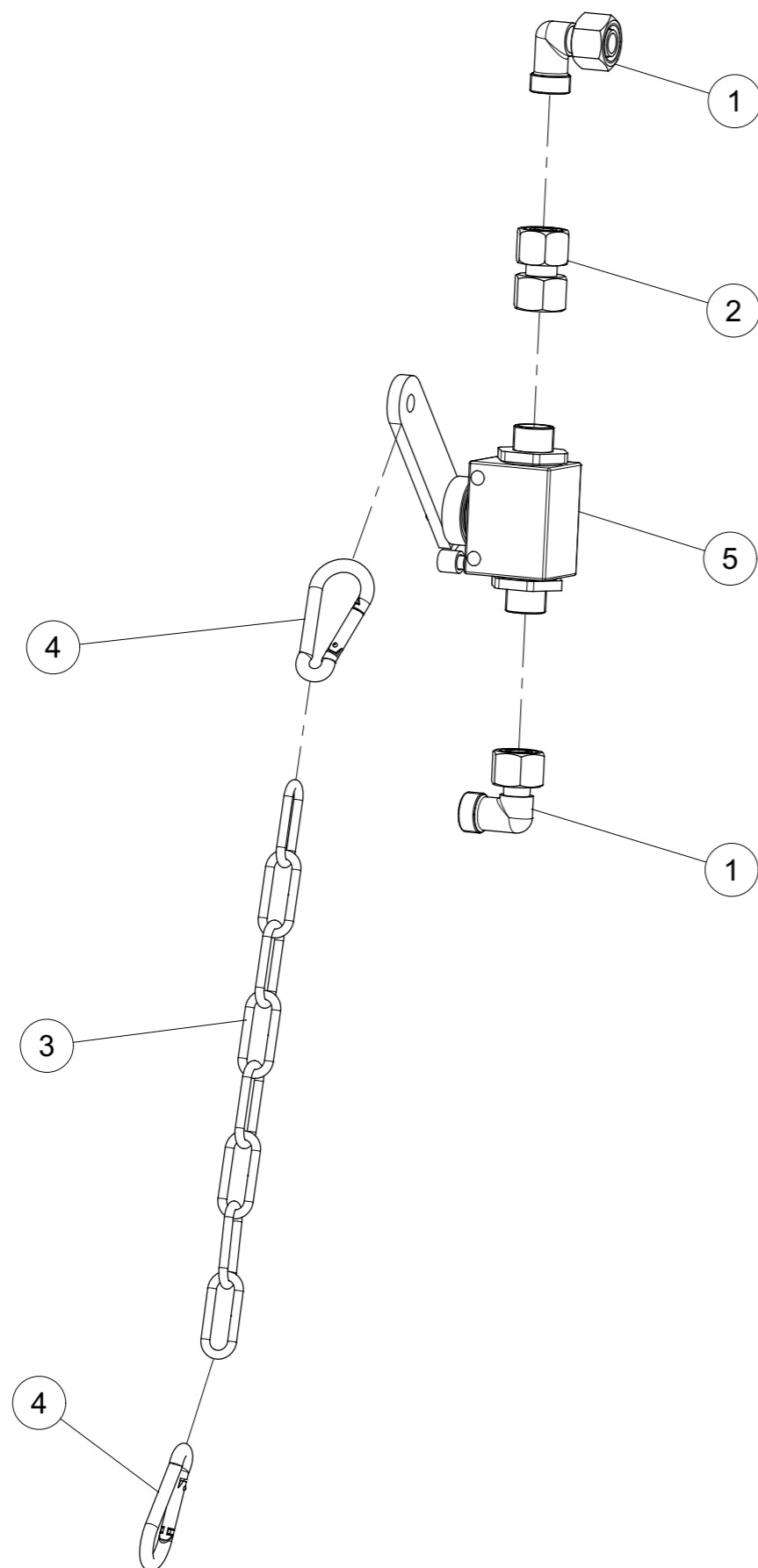

Pos. / Index	Stck. / Qty	Artikel-Nr.	Benennung / Designation
1	2	4716.52.11	Winkelverschraubung Einstellbar
2	1	4716.53.05	Doppelmutter DMO (40lg)
3	1	763D0.256K4	O.256m Kette 4 8 glieder DIN763
4	2	8423.28.05	Karabinerhaken 60x6
5	1	8423.31.01	Hubbegrenzer 12 L

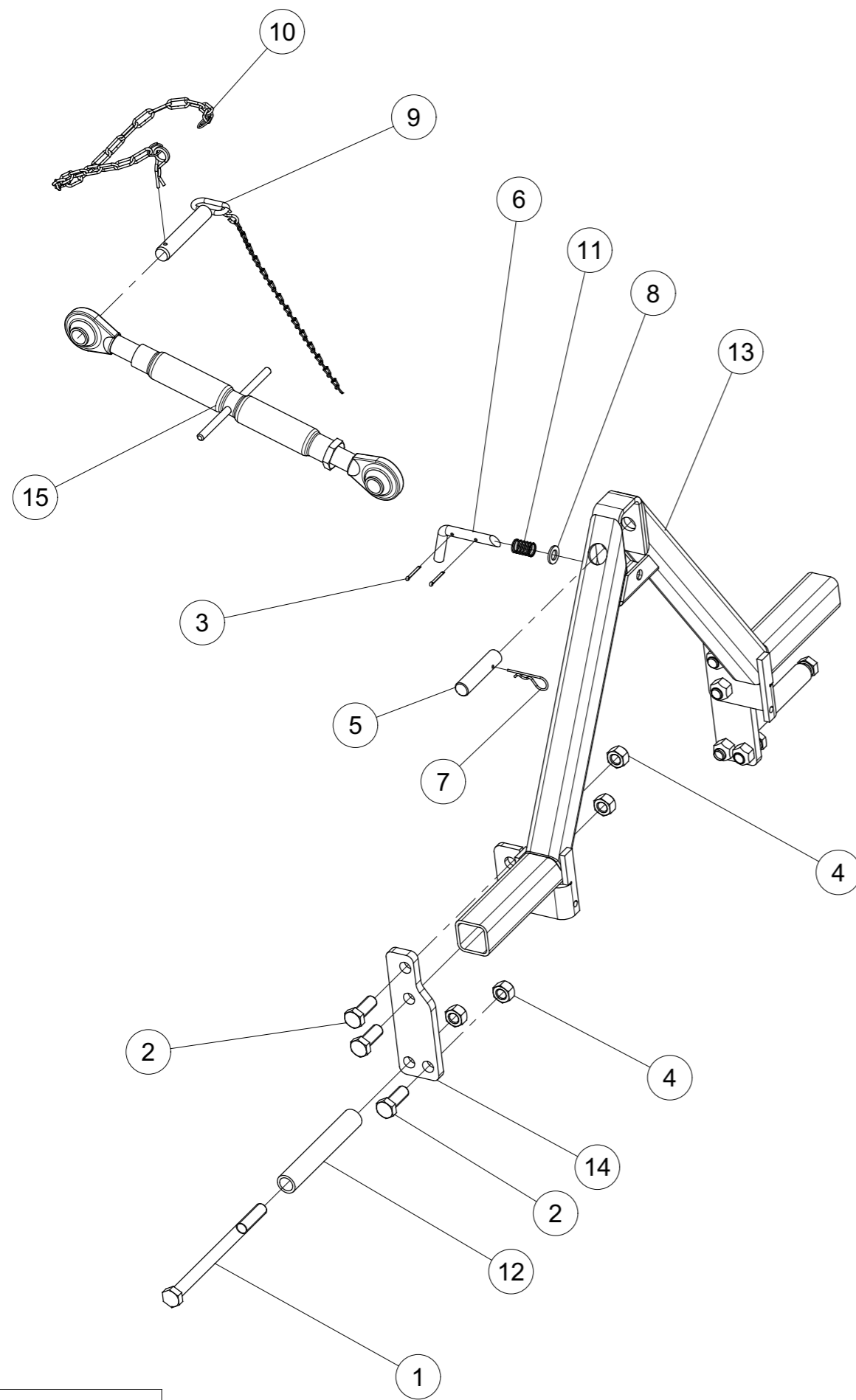

Pos. / Index	Stck. / Qty	Artikel-Nr.	Benennung / Designation
1	2	931D20280NA	Hex. Schraube M20 x 280 Verzinkt 10.9 Hex. Screw M20 x 280 Zinc 10.9
2	6	933D2050NA	hex. Schraube M20x50 ISO4017-10.9 verzinkt Hex. Screw M20x50 ISO4017-10.9 Zinc
3	2	94D432	SPLINT 4x 25 ISO1234 Z cotter pin 4x 25 ISO1234 Z
4	8	980DV20NA	Sicherungsmutter M20 Verzinkt 10.9 Nut M20 Zinc 10.9
5	1	1000.48.01	Bolzen Ø 25-110
6	1	1000.48.06	Verriegelungsbolzen
7	1	11024DE3A	FEDERSTECKER-11024 3 Z EW
8	1	125DA17A	SCHEIBE A 17 ISO7089 VERZ.
9	1	4716.09.00	Steckbolzen D25-125 (TB-25-130A)
10	1	6344.40.08	Sicherungskette
11	1	8412.55.06	Druckfeder
12	2	8446.03.12	SR33745X214X
13	1	8446.08.07	Satteldreieck gs.
14	2	8446.08.20	Verbindung
15	1	9108.78.03	Oberlenker Kat II, M30x3.5 Kpl. (500-750 mm)

Satteldreieck für Fremdfabrikate

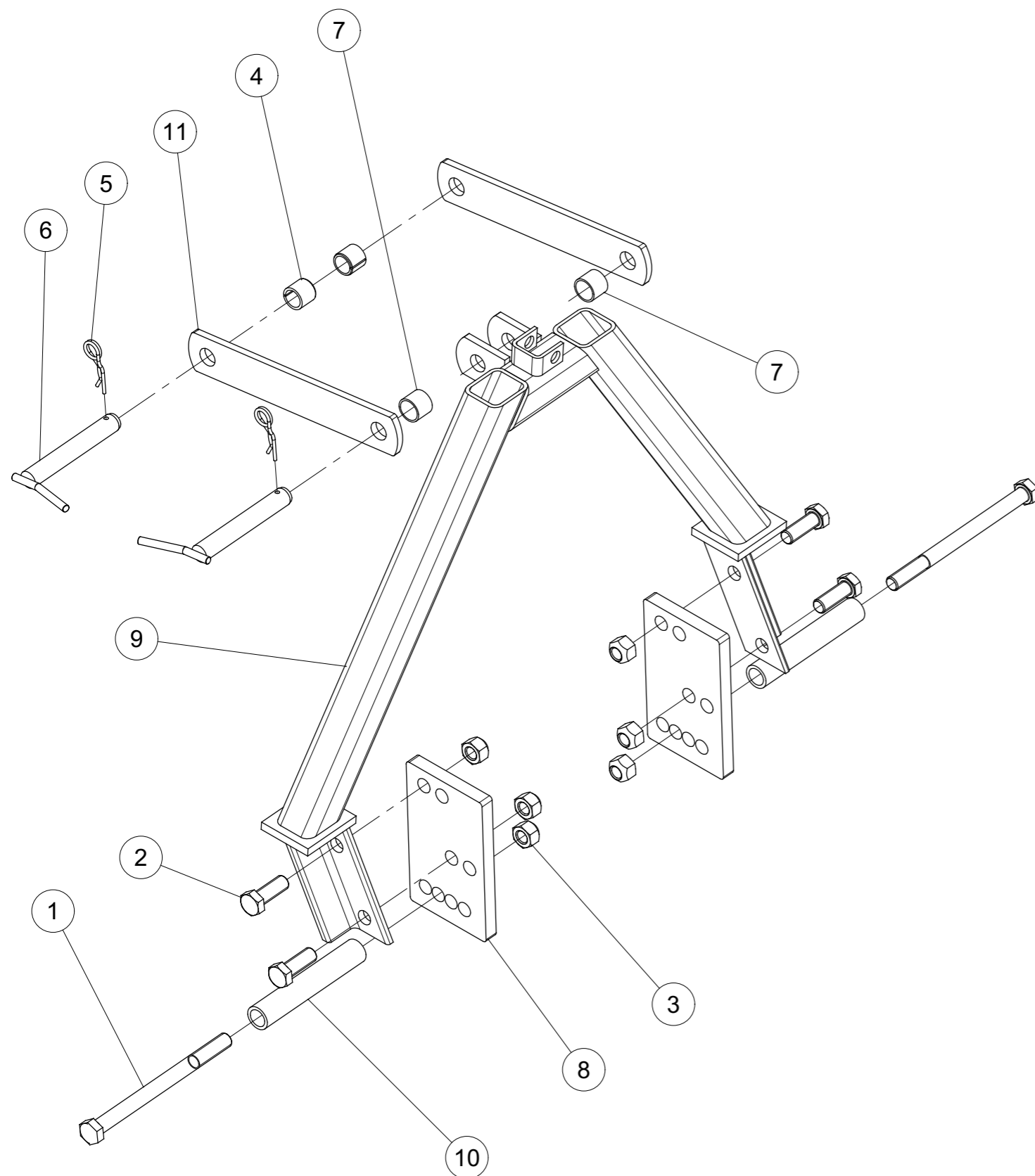

Pos. / Index	Stck. / Qty	Artikel-Nr.	Benennung / Designation
1	2	931D20260NA	Hex. Schraube M20 x 260 Verzinkt 10.9 Hex. Screw M20 x 260 Zinc 10.9
2	4	933D2055NA	hex. Schraube M20x40 ISO4017-10.9 verzinkt Hex. Screw M20x40 ISO4017-10.9 Zinc
3	6	980DV20NA	Sicherungsmutter M20 Verzinkt 10.9 Nut M20 Zinc 10.9
4	2	1498D253228	BUCHSE EG 25/32x28 DIN1498
5	2	11024D4A	FEDERSTECKER-11024 4 Z DW
6	2	8404.74.00	Steckstock
7	2	8412.55.04	Rohr
8	2	8412.55.10	Verstellplatte
9	1	8426.30.00	Satteldreieck
10	2	8437.19.40	SR33745X195
11	2	9003.23.98	Lasche D26-295

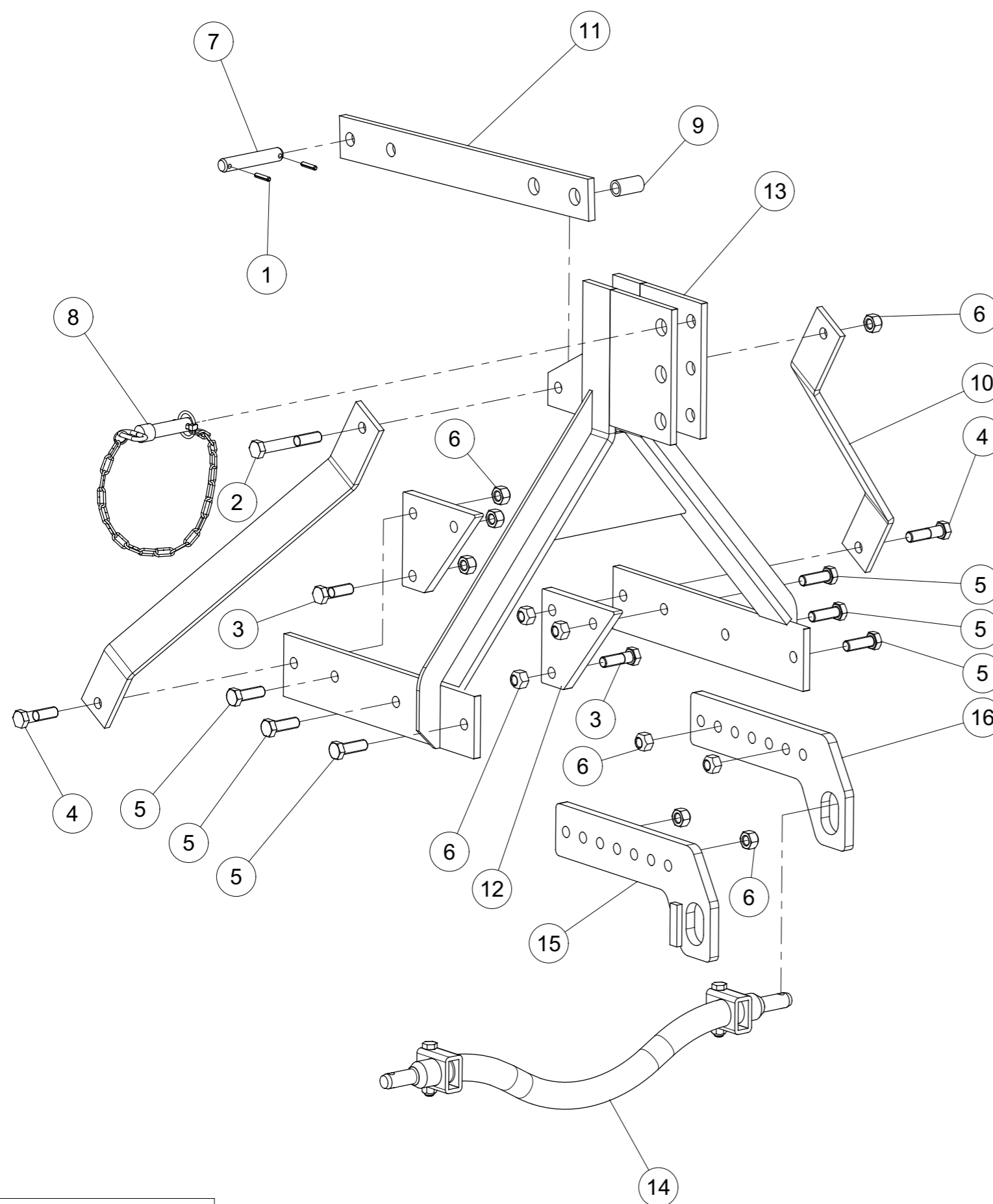

Pos. / Index	Stck. / Qty	Artikel-Nr.	Benennung / Designation
1	2	1481D840A	SPANNSTIFT 8 X 40 ISO8752 VERZ. Spring Pin 8 X 40 ISO8752 Z Goupille elastique 8 X 40 ISO8752 Z
2	1	931D20140PA	Hex. Schraube M20 x 140 Verzinkt 8.8 Hex. Screw M20 x 140 Zinc 8.8 Vis H M20 x 140 ZNBL 8.8
3	2	931D2065PA	Hex. Schraube M20 x 65 Verzinkt 8.8 Hex. Screw M20 x 65 Zinc 8.8 Vis H M20 x 65 ZNBL 8.8
4	2	931D2075P	Hex. Schraube M20 x 75 Blank 8.8 Hex. Screw M20 x 75 Black 8.8 Vis H M20 x 75 Noire 8.8
5	6	933D2060PA	hex. Schraube M20x60 ISO4017-8.8 verzinkt Hex. Screw M20x60 ISO4017-8.8 Zinc Vis H M20x60 ISO4017-8.8 ZNBL
6	11	980DV20PA	Sicherungsmutter M20 Verzinkt 8.8 Nut M20 Zinc 8.8 Ecrou M20 ZNBL 8.8
7	1	1000.25.04	Bolzen D25x120 verz.
8	1	6333.09.00	OL-Stock Kat.II DTB-112X87
9	1	8406.54.01	Distanzhülse
10	2	8406.54.03	Haltestrebe
11	1	8406.54.05	Turmstrebe
12	2	8406.54.07	Anschraubplatte
13	1	8406.65.00	Frontturm
14	1	8406.66.03	Dreipunktachse Kat.II kpl. montiert
15	1	8435.19.05	Anschlußstück li.
16	1	8435.19.10	Anschlußschiene

Frontanbau f. Drill-Lift Kat 2 montiert

Pos. / Index	Stck. / Qty	Artikel-Nr.	Benennung / Designation
1	1	8406.83.09	Frontanbau Drill-Lift Kat 2 mech.
2	1	8406.83.10	Frontanbau Drill-Lift hyd. Erweiterung

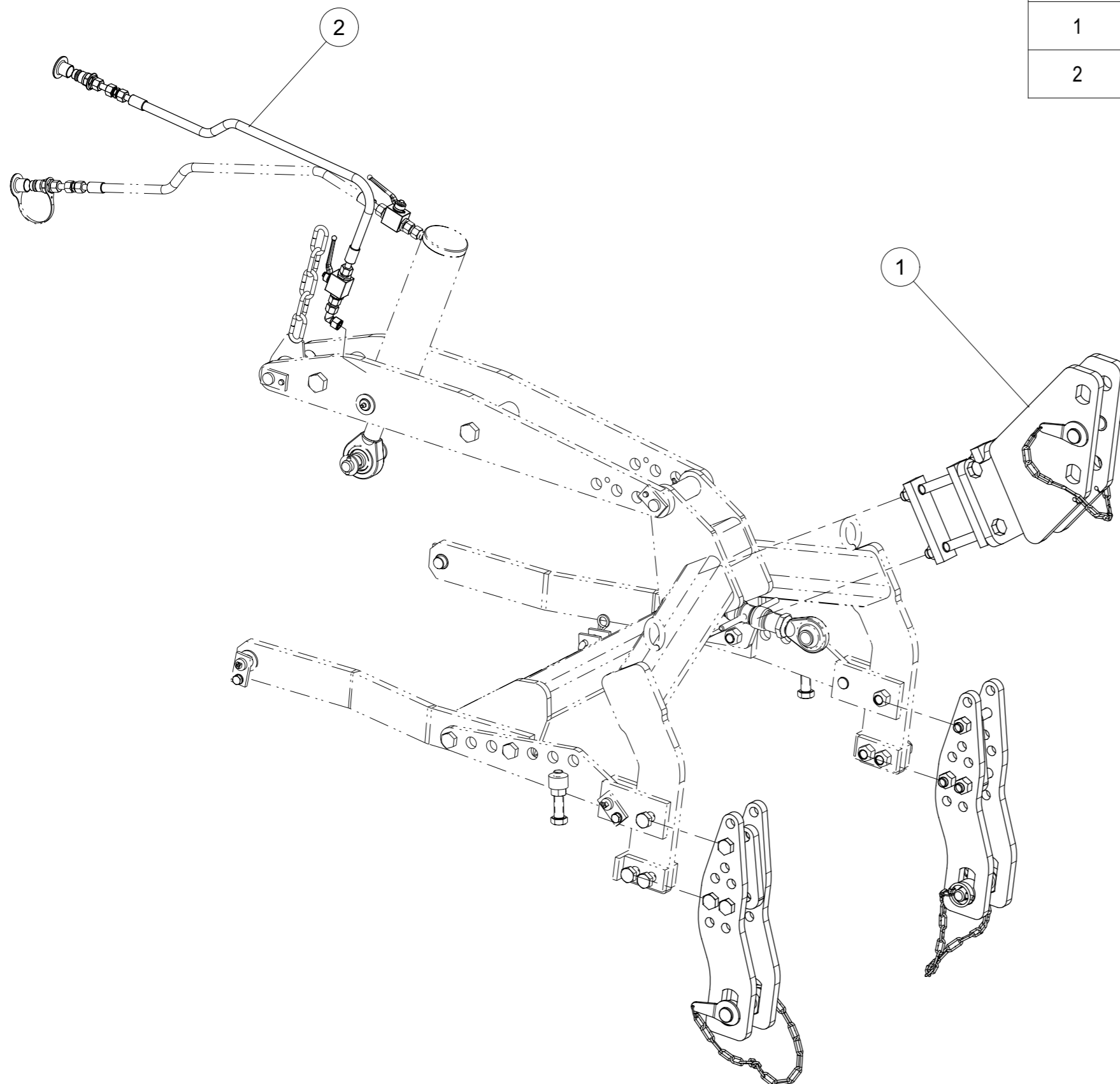

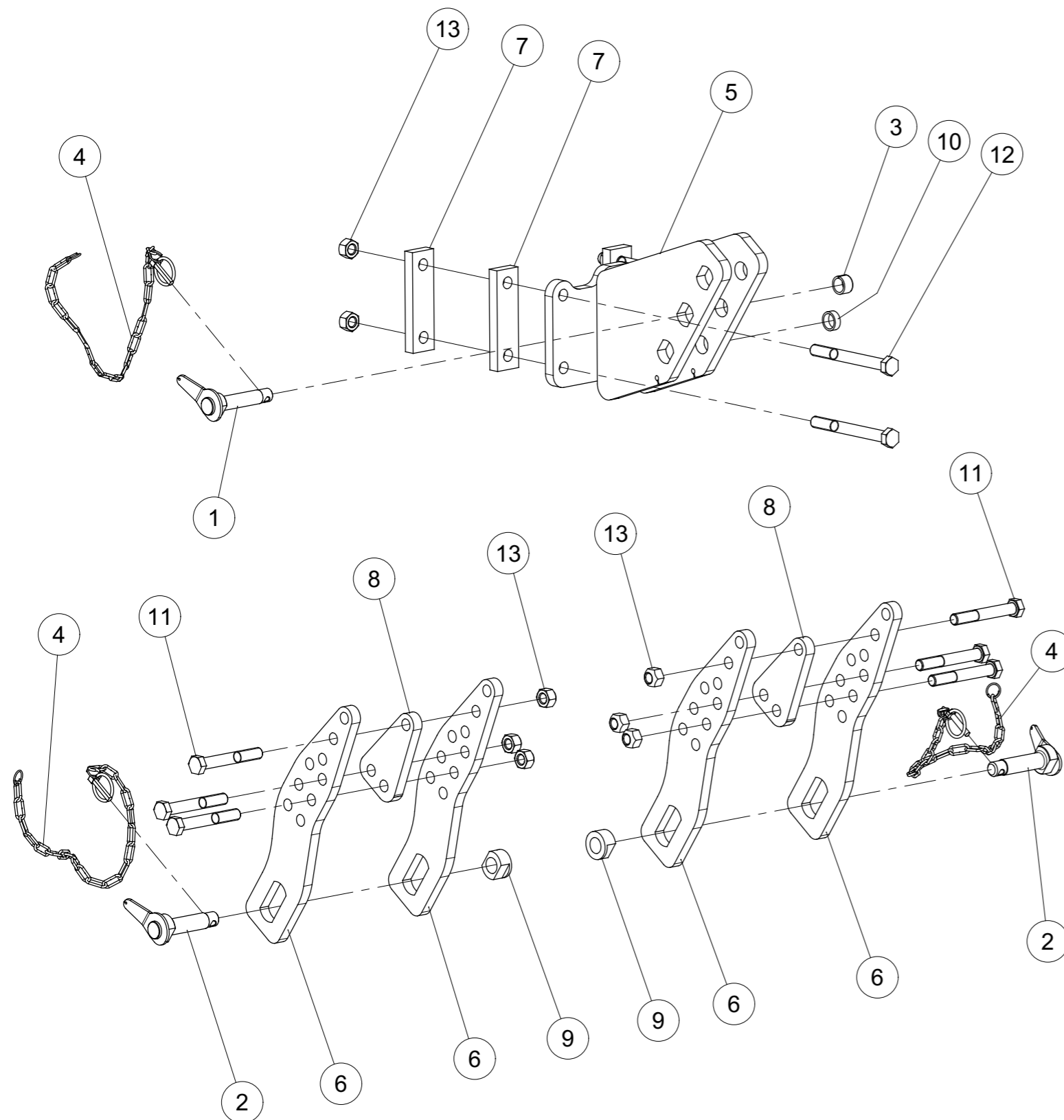

Pos. / Index	Stck. / Qty	Artikel-Nr.	Benennung / Designation
1	1	1100.00.50	Oberlenkerbolzen Kat.2 geschw.
2	2	1200.04.01	Unterlenkerbolzen Kat. 2 geschw.
3	1	1498D253220	Einspannbuchse
4	3	6344.40.02	Sicherungskette Kat. 2
5	1	8406.81.06	Oberlenkerhalter
6	4	8406.82.05	UL-Aufnahme außen
7	4	8406.83.03	Lasche D21-130
8	2	8406.83.12	Distanzplatte
9	2	8406.83.13	Distanzhülse
10	1	8406.83.14	Rohr 1R (33.7x3.25)
11	6	931D20140PA	6kant-Schraube, DIN 931 Hex. Screw M20 x 140 Zinc 8.8 Vis H M20 x 140 ZNBL 8.8
12	4	931D20190PA	6kant-Schraube, DIN 931 Hex. Screw M20 x 190 Zinc 8.8 Vis H M20 x 190 ZNBL 8.8
13	10	980DV20PA	Sicherungsmutter, DIN 980 Nut M20 Zinc 8.8 Ecrou M20 ZNBL 8.8

Frontanbau Drill-Lift hyd. Erweiterung

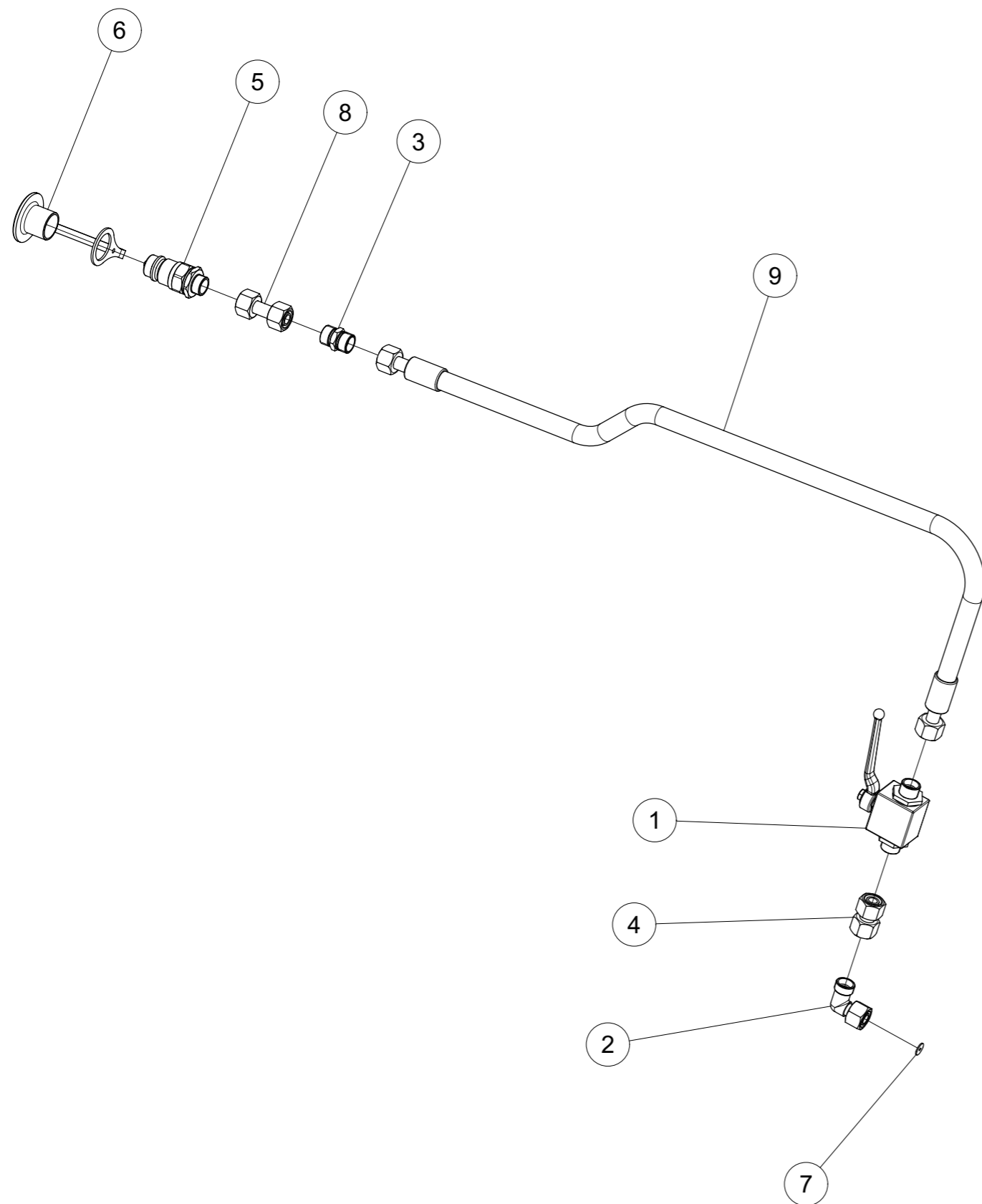

Pos. / Index	Stck. / Qty	Artikel-Nr.	Benennung / Designation
1	1	4716.46.05	HD-Blockkugelhahn NW10 verz.
2	1	4716.52.11	Winkelverschraubung Einstellbar
3	1	4716.52.13	Gerade Verschraubung G12-L - M18x1,5
4	1	4716.53.05	Doppelmutter DMO NW10L
5	1	8132.01.00	Hydr. Stecker HL3 AG M18x1,5
6	1	8132.05.01	Staubkappe
7	1	8132.06.04	Drosselscheibe \varnothing 2.5
8	1	8172.02.28	Hydraulikrohr 50 lg. kpl. (NW10)
9	1	8413.88.01	Hydr.Schlauch 2SN DN10 1500 D20022

Getriebe - Durchtrieb 1 3/4" Z6

Artikel Nr.	Benennung / Designation	1 Traktoranschluß Tractor connection Connexion Tracteur	Länge Length Longueur	
8444.08.21	GLW + Reibkupplung R + L PTO shaft + Friction Clutches R + L Cardan + embrayage à friction R + L	1 3/8" Z 6	1010 mm	Standard
8444.08.22	GLW + Reibkupplung R + L / PTO shaft + Friction Clutches R + L Cardan + embrayage à friction R + L	1 3/8" Z 21	1010 mm	Sonderbestellung ⁽¹⁾ Spezial order ⁽¹⁾ commande spéciale ⁽¹⁾
8444.08.23	GLW + Reibkupplung R + L PTO shaft + Friction Clutches R + L Cardan + embrayage à friction R + L	1 3/4" Z 6	1010 mm	Sonderbestellung ⁽¹⁾ Spezial order ⁽¹⁾ commande spéciale ⁽¹⁾
8444.08.24	GLW + Reibkupplung R + L PTO shaft + Friction Clutches R + L Cardan + embrayage à friction R + L	1 3/4" Z 20	1010 mm	Sonderbestellung ⁽¹⁾ Spezial order ⁽¹⁾ commande spéciale ⁽¹⁾

¹⁾ Sonderbestellung mit Lieferzeit / spezial order with delivery time / commande spéciale avec délai de livraison

Getriebe - Durchtrieb 1 3/8" Z6

Artikel Nr.	Benennung / Designation	1 Traktoranschluß Tractor connection Connexion Tracteur	Länge Length Longueur	
8444.08.41	GLW + Reibkupplung R + L PTO shaft + Friction Clutches R + L Cardan + embrayage à friction R + L	1 3/8" Z 6	1010 mm	Standard
8444.08.42	GLW + Reibkupplung R + L PTO shaft + Friction Clutches R + L Cardan + embrayage à friction R + L	1 3/8" Z 21	1010 mm	Sonderbestellung ⁽¹⁾ Spezial order ⁽¹⁾ commande spéciale ⁽¹⁾
8444.08.43	GLW + Reibkupplung R + L PTO shaft + Friction Clutches R + L Cardan + embrayage à friction R + L	1 3/4" Z 6	1010 mm	Sonderbestellung ⁽¹⁾ Spezial order ⁽¹⁾ commande spéciale ⁽¹⁾
8444.08.44	GLW + Reibkupplung R + L PTO shaft + Friction Clutches R + L Cardan + embrayage à friction R + L	1 3/4" Z 20	1010 mm	Sonderbestellung ⁽¹⁾ Spezial order ⁽¹⁾ commande spéciale ⁽¹⁾

¹⁾ Sonderbestellung mit Lieferzeit / spezial order with delivery time / commande spéciale avec délai de livraison

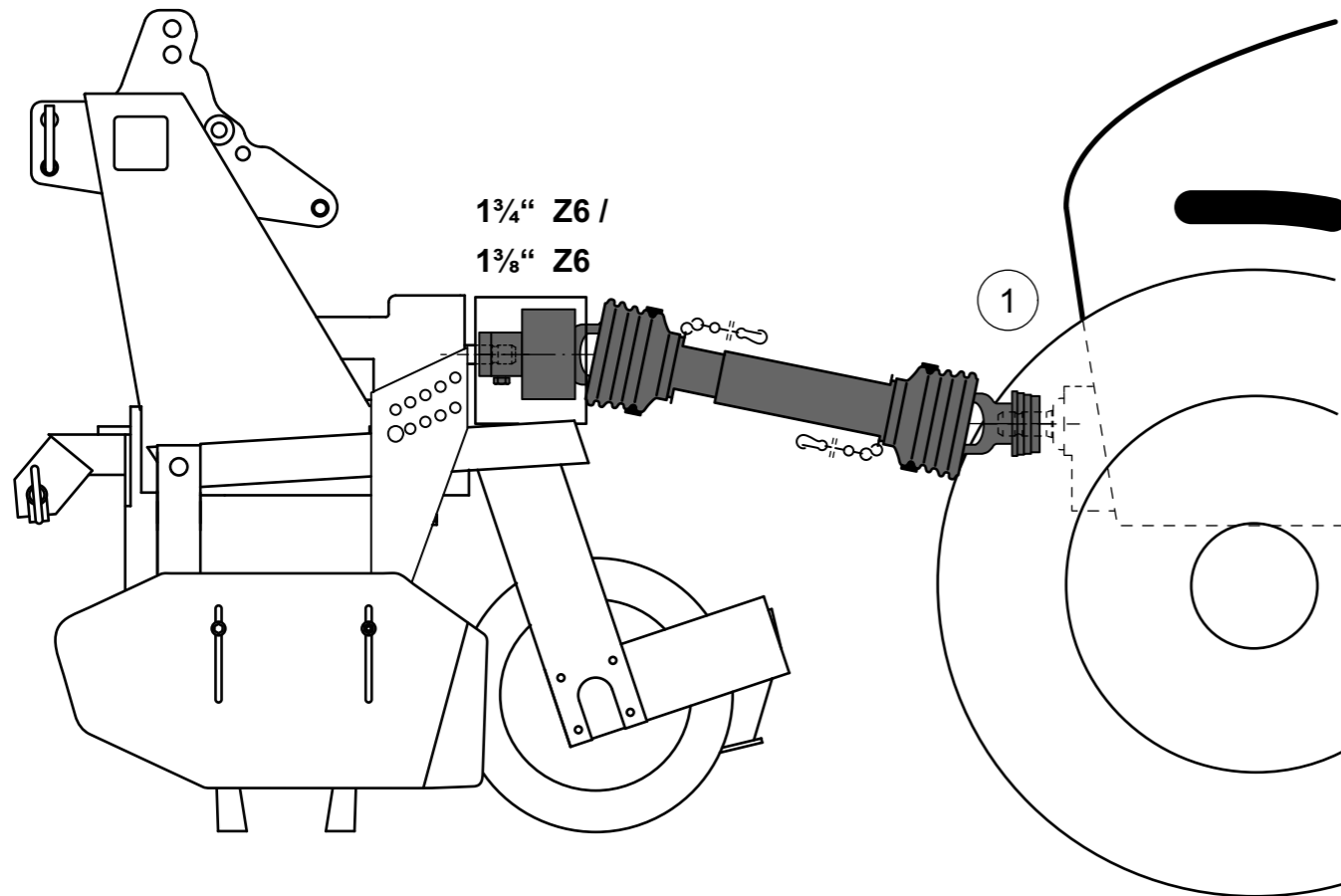

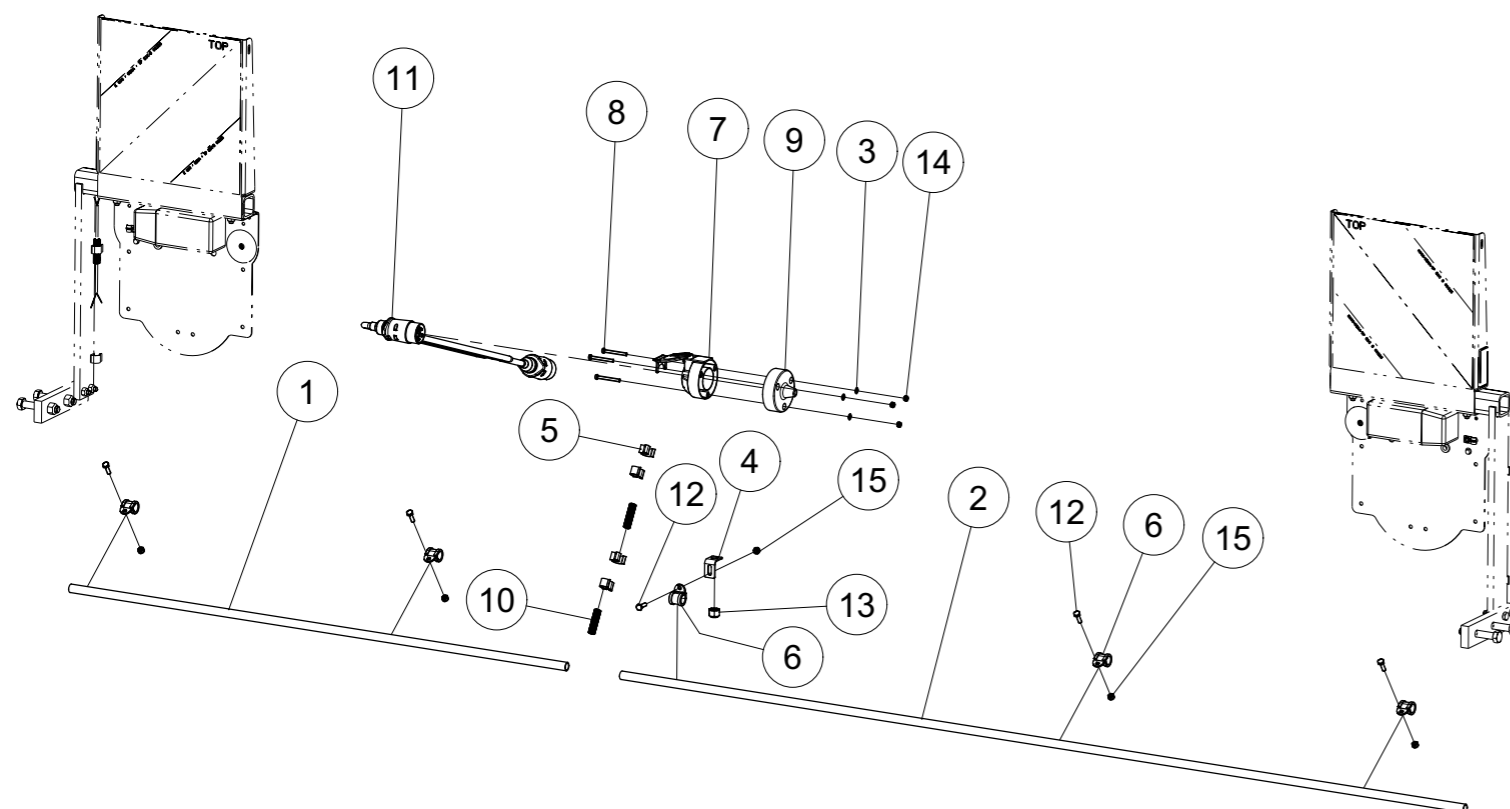

Pos. / Index	Stck. / Qty	Artikel-Nr.	Benennung / Designation
1	1	1020.04.01	HR1515X1000
2	1	1020.04.02	HR1515X1700
3	3	125DA5.3A	SCHEIBE A 5,3 ISO7089 VERZ. Washer A 5,3 ISO7089 Zinc. Rondelle A 5,3 ISO7089 Zinguée
4	1	6103.09.85	Halter
5	4	6103.18.01	Traegerklemme SRV T=4-7 D=12-14
6	5	8172.15.15	Schlauchschelle NRS 15-20 verz.
7	1	8416.65.01	Steckdose 7-polig Kunststoff schwarz
8	3	84D545WA	ZYL.SCHR.M5x45 ISO1207-4.8 Z
9	1	9004.18.55	Staubkappe
10	2	9009.43.00	WELLROHR NW 8.5 - 0.750 m
11	1	9032.37.34	Zwischenkabel 4.3m 7-polig
12	5	933D620PA	hex. Schraube M6x20 ISO4017-8.8 verzinkt Hex. Screw M6x20 ISO4017-8.8 Zinc Vis H M6x20 ISO4017-8.8 ZNBL
13	1	980DV12NA	Sicherungsmutter M12 Verzinkt 10.9 Nut M12 Zinc 10.9 Ecrou M12 ZNBL 10.9
14	3	985D5PA	SICHM. M5 ISO10511-8 Z Nyloc Nut M5 ISO10511-8 Z Ecrou HFR M5 ISO10511-8 Z
15	5	985D6PA	SICHM. M6 ISO10511-8 Z Nyloc Nut M6 ISO10511-8 Z Ecrou HFR M6 ISO10511-8 Z

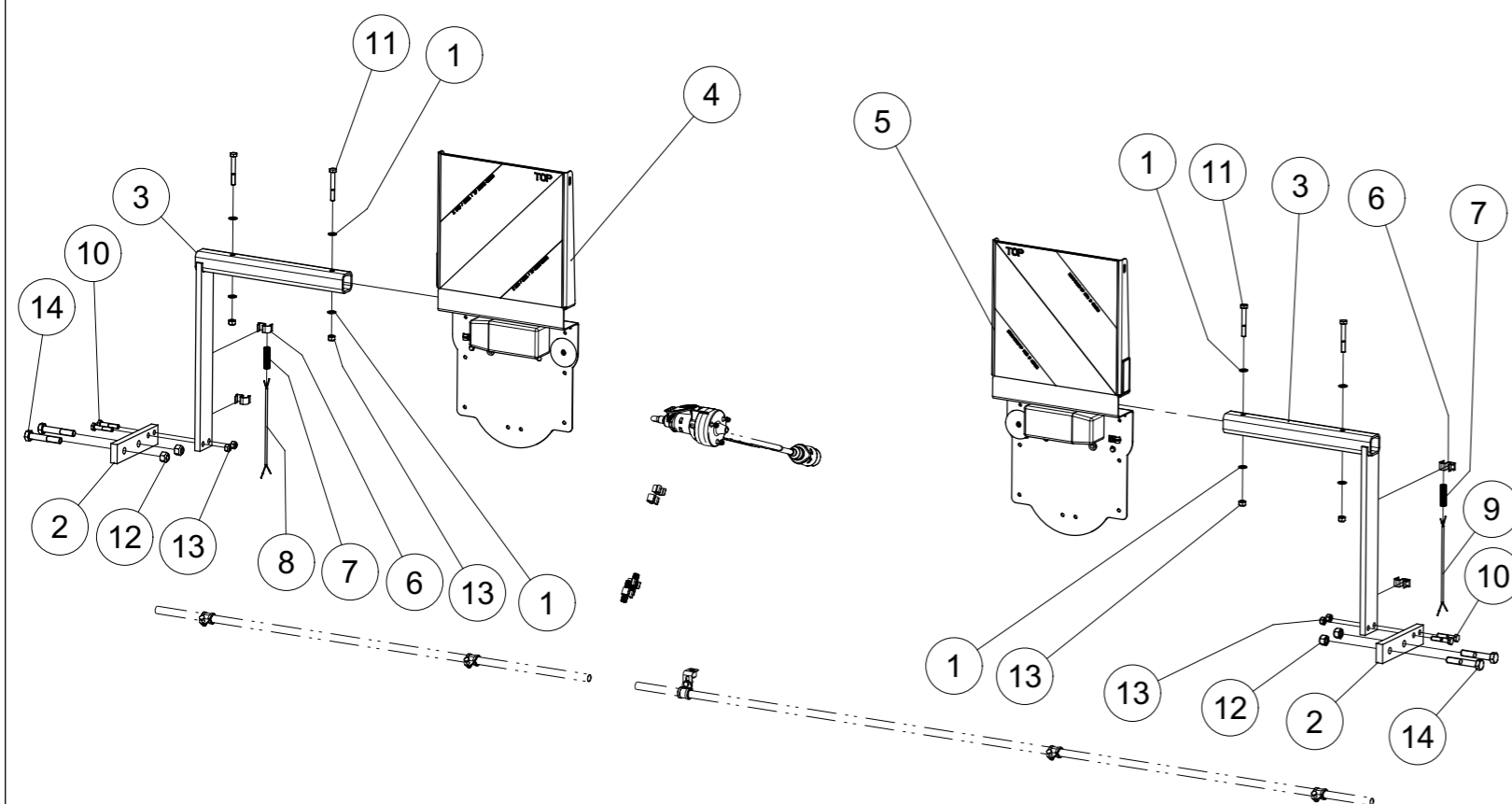

Pos. / Index	Stck. / Qty	Artikel-Nr.	Benennung / Designation
1	8	125DA8.4A	SCHEIBE A 8,4 ISO7089 VERZ. Washer A 8,4 ISO7089 Zinc. Rondelle A 8,4 ISO7089 Zinguée
2	2	6103.16.12	Träger
3	2	6103.16.14	Warnblechträger
4	1	6103.16.38	Warntafel hinten li. mont. Pos.-leuchte b
5	1	6103.16.48	Warntafel hinten re. mont. Pos.-leuchte b
6	4	6103.18.04	Traegerklemme Typ SRV T=8-12 D=12-14
7	2	9009.43.00	WELLROHR NW 8.5 - 0.700 m
8	1	9012.80.00	Kabel Schwarz flexibel 4X0.75 - 2.80 m
9	1	9012.80.00	Kabel Schwarz flexibel 4X0.75 - 3.50 m
10	4	931D840PA	Hex. Schraube M8 x 40 Verzinkt 8.8 Hex. Screw M8 x 40 Zinc 8.8 Vis H M8 x 40 ZNBL 8.8
11	4	931D860PA	Hex. Schraube M8 x 60 Verzinkt 8.8 Hex. Screw M8 x 60 Zinc 8.8 Vis H M8 x 60 ZNBL 8.8
12	4	980DV12PA	Sicherungsmutter M12 Verzinkt 8.8 Nut M12 Zinc 8.8 Ecrou M12 ZNBL 8.8
13	8	980DV8PA	Sicherungsmutter M8 Verzinkt 8.8 Nut M8 Zinc 8.8 Ecrou M8 ZNBL 8.8
14	4	VI 29 16	Schraube H M12x 70 - 8.8 ZNBL Screw H M12x 70 - 8.8 ZNBL Vis H M12x 70 - 8.8 ZNBL

Warntafel hinten li. mont. Pos.-leuchte b

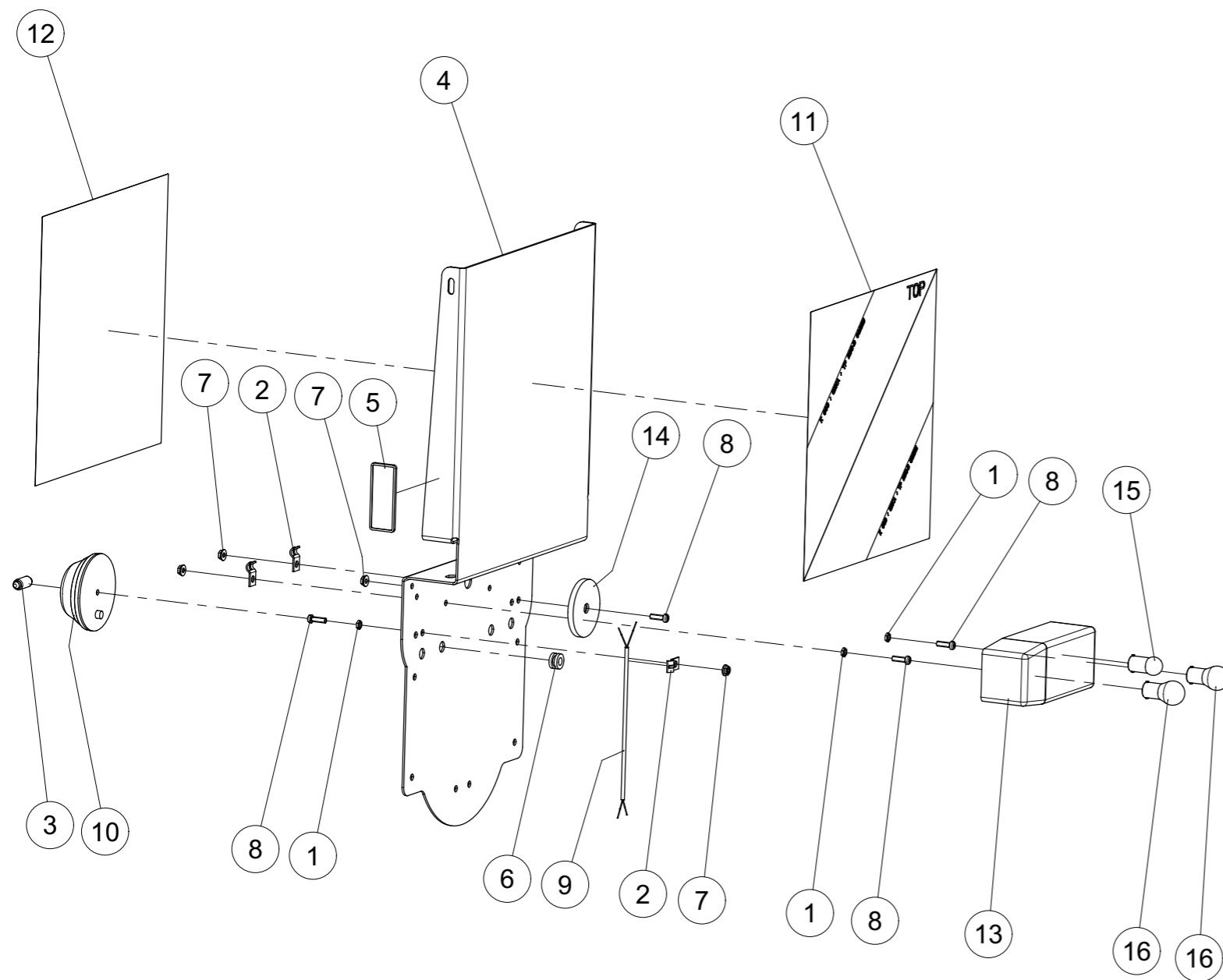

Pos. / Index	Stck. / Qty	Artikel-Nr.	Benennung / Designation
1	3	439DAM5SA	FL.6KTM AM 5 ISO4035-4 Z
2	3	6103.05.40	Befestigungsschelle D7 verz.
3	1	6103.09.34	Glühlampe C5W 12V/5W, Sockel SV8.5-8 kurz
4	1	6103.16.03	Warntafelblech hinten
5	1	6103.16.05	Rückstrahler rechteckig gelb selbstklebend
6	1	6103.16.70	Durchführungsstülpe
7	4	6923D5RA	6KTM M5 MIT BUND DIN6923- 5 Z
8	4	84D516WA	ZYL.SCHR.M5x16 ISO1207-4.8 Z
9	1	9012.81.00	Kabel Schwarz flexibel 2X0.75 - 0.20 m
10	1	9018.27.05	Positionleuchte
11	1	9032.37.58	Warnmarkierung li.
12	1	9032.37.59	Warnmarkierung re.
13	1	9037.26.12	Blink-Brems-Schluss Leuchte li.
14	1	9108.80.01	Rückstrahler rund f. M6
15	1	9108.80.06	Glühlampe 12V/10W
16	2	9108.80.07	Glühlampe 12V/21W

Warntafel hinten re. mont. Pos.-leuchte b

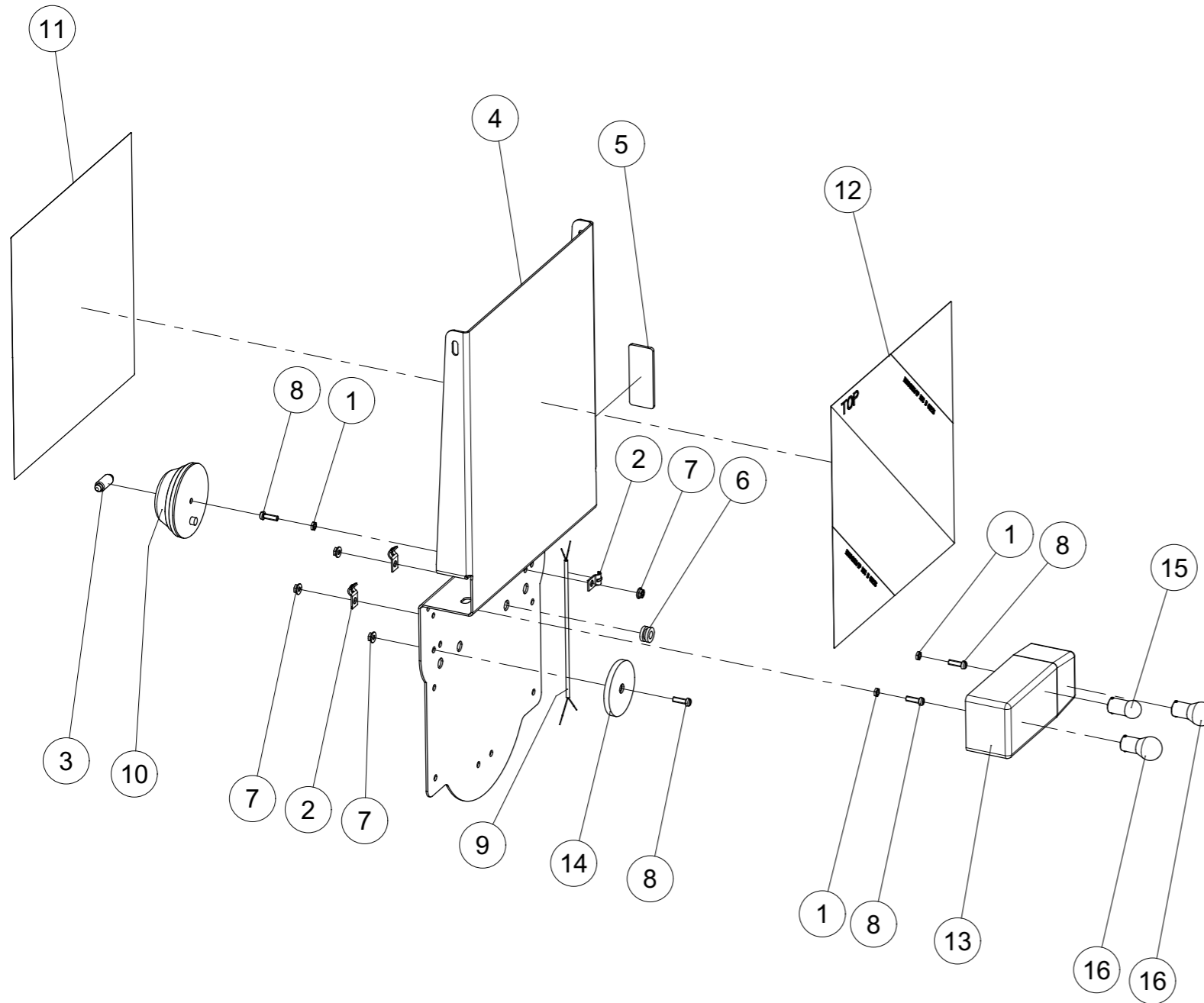

Pos. / Index	Stck. / Qty	Artikel-Nr.	Benennung / Designation
1	3	439DAM5SA	FL.6KTM AM 5 ISO4035-4 Z
2	3	6103.05.40	Befestigungsschelle D7 verz.
3	1	6103.09.34	Glühlampe C5W 12V/5W, Sockel SV8.5-8 kurz
4	1	6103.16.03	Warntafelblech hinten
5	1	6103.16.05	Rückstrahler rechteckig gelb selbstklebend
6	1	6103.16.70	Durchführungstülle
7	4	6923D5RA	6KTM M5 MIT BUND DIN6923- 5 Z
8	4	84D516WA	ZYL.SCHR.M5x16 ISO1207-4.8 Z
9	1	9012.81.00	Kabel Schwarz flexibel 2X0.75 - 0.20 m
10	1	9018.27.05	Positionleuchte
11	1	9032.37.58	Warnmarkierung li.
12	1	9032.37.59	Warnmarkierung re.
13	1	9037.26.13	Blink-Brems-Schluss Leuchte re.
14	1	9108.80.01	Rückstrahler rund f. M6
15	1	9108.80.06	Glühlampe 12V/10W
16	2	9108.80.07	Glühlampe 12V/21W

Pos. / Index	Stck. / Qty	Artikel-Nr.	Benennung / Designation
1	2	933D616PA	hex. Schraube M6x16 ISO4017-8.8 verzinkt Hex. Screw M6x16 ISO4017-8.8 Zinc
2	2	985D6PA	SICHM. M6 ISO10511-8 Z SICHM. M6 ISO10511-8 Z
3	1	610.16.44	Warntafel seitlich Re hinten mont. FRA NK
4	1	6103.16.41	Warntafel seitlich Li hinten mont. FRA NK
5	4	9021DA6.4A	Scheibe, DIN 9021

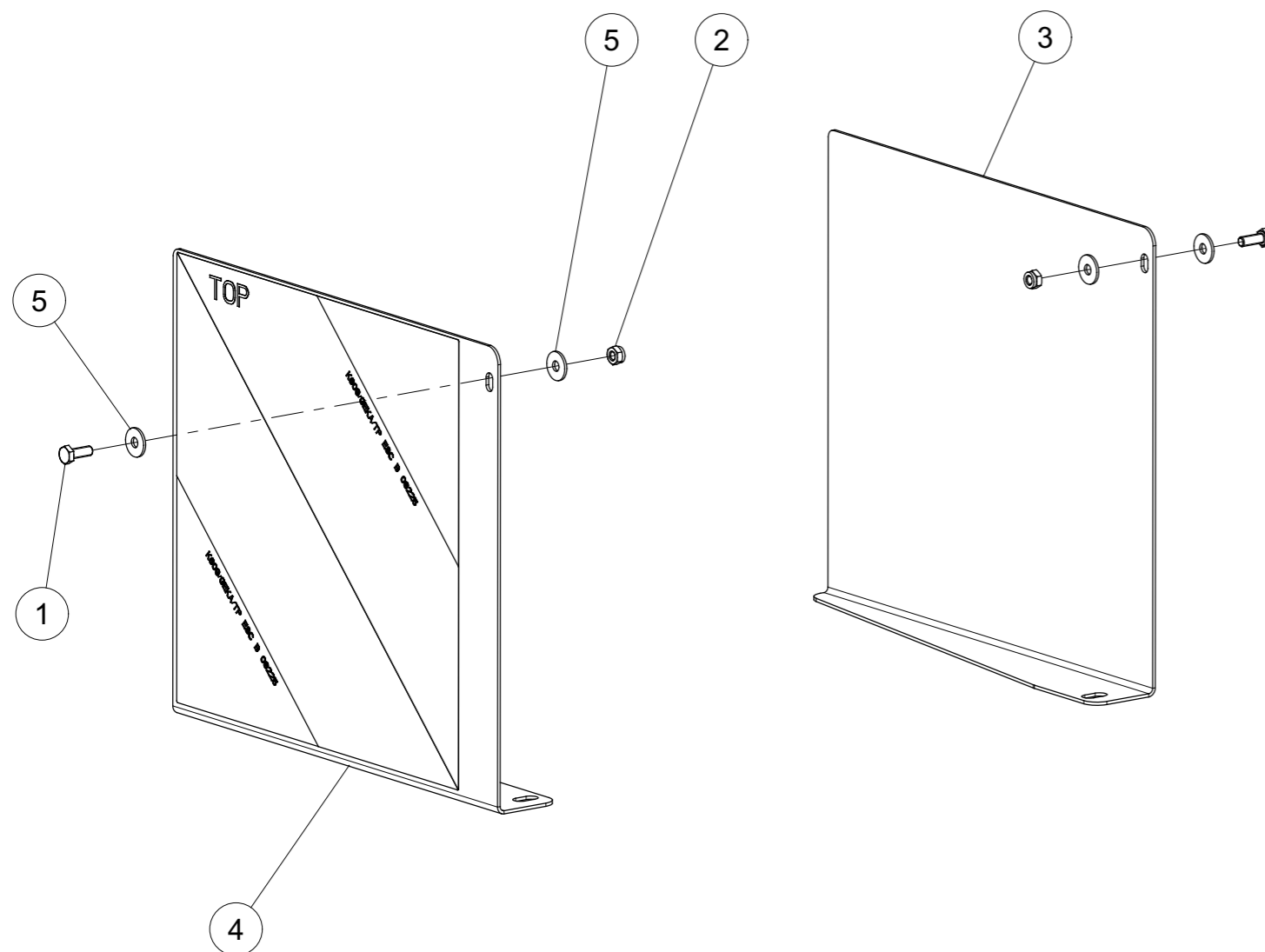



GRÉGOIRE-BESSON FRANCE

49230 Montfaucon / Montigné-sur-Moine
France
Tél. (+33) 2 41 64 72 67
Fax (+33) 2 41 64 67 73
contactfr@gregoirebesson.fr
www.gregoire-besson.com

Grégoire-Besson GmbH

Am Rabewerk 1
49152 Bad Essen
Deutschland
Tél. +49 (0) 54 72 771 - 0
Fax +49 (0) 54 72 771 -195
info@rabe-agri.eu
www.rabe-gb.de

GREGOIRE-BESSON UK LIMITED

Spalding Road - Bourne - Lincs. PE10 0AU.
England
Phone : +441778423787
Fax : +441778394431
email
www.gregoire-besson.co.uk

GRÉGOIRE-BESSON CANADA INC

4480, Rue Martineau - St Hyacinthe (P. Québec) - J2R 1V1
Canada
Tel : (1) 450 799 56 15
Fax : (1) 450 799 56 29
info@gregoirebesson.ca
www.gregoire-besson.com

GREGOIRE-BESSON POLSKA Sp.zo.o.

Kowanówko
ul. Obornicka 1a - 64-600 Oborniki
Polska
Tel: (+48) 61 297 75 30
fax: (+48) 61 297 22 62
gbesson@poczta.onet.pl
www.gregoire-besson.pl

Представительство Rabe по России и Беларуси

308006, г.Белгород, ул. Корочанская 132 А,
Россия (RUSSIA)
тел./факс: +7(4722)58-70-35,58-70-36
rabe.russia@gmail.ru, rabe.belarus@gmail.com
www.gregoire-besson.com

ТОВ «ГРЕГУАР-БЕССОН УКРАЇНА»

18028, Україна, Черкаська обл.
м. Черкаси, вул. Рози Люксембург, буд. 202.
Украина (UKRAINE)
тел. / факс : +38 (0472) 71-28-23
rabe.ukrainia@yandex.ua
www.gregoire-besson.com

GREGOIRE-BESSON BEIJING OFFICE

法国格力格尔-贝松公司 北京代表处
100025北京市朝阳区延静里中街3号长信大厦220室
China
电话 : 0086-10-65 08 06 40
传真 : 0086-10-65 08 06 41
www.gregoire-besson.com