

Bestell-Nr. ET2213DE
(Bestell-Nr. Betriebsanleitung 9900.00.17DE03)

--	--	--	--	--	--	--	--	--

Maschinen-Nr.

Ersatzteilliste

Kreiseleggen

Corvus PKE Br.5

Corvex P Br. 6



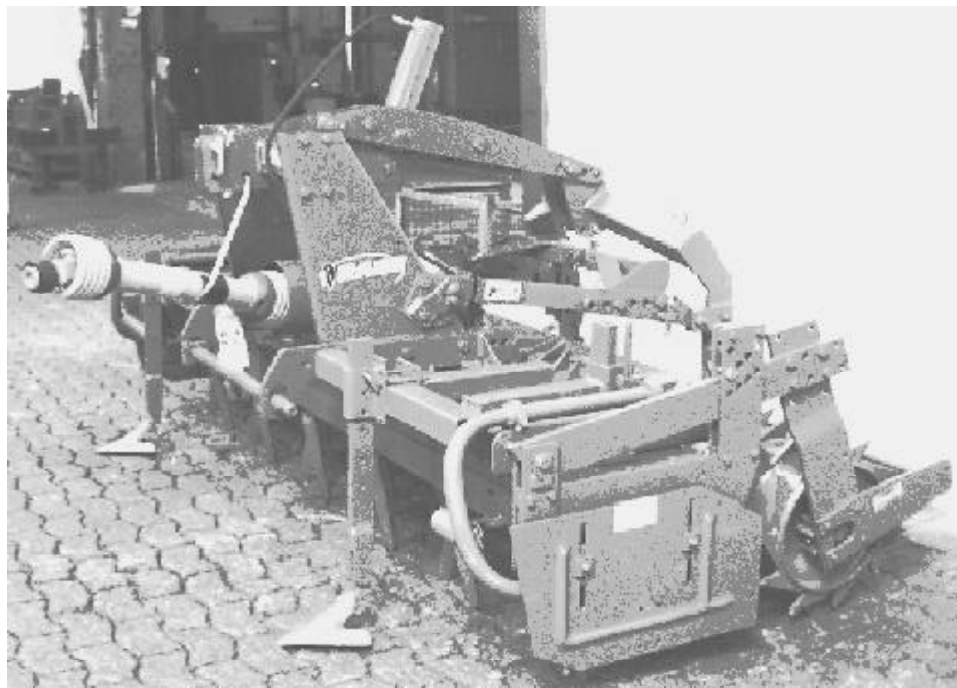

Référence ET2213FR
(Référence pour notice d'instruction 9900.00.17FR03)

--	--	--	--	--	--	--	--	--

Numéro machine

Liste des pièces de rechange

Herses rotatives

Corvus PKE Série 5

Corvex P Série 6



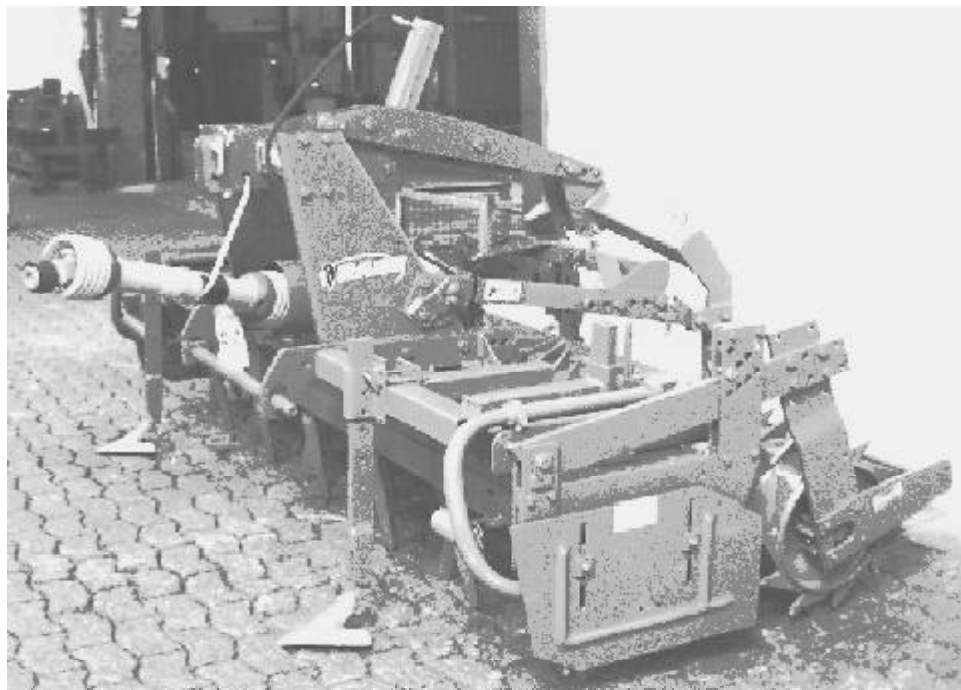

Order No. ET2213GB
(Order No. of operating instruction 9900.00.17GB03)

--	--	--	--	--	--	--	--	--

Serial number

Spare Parts List

Rotary Harrow

Corvus PKE Serie 5

Corvex P Serie 6



A	Turm, Werkzeugträger	Headstock, trough	Tête, caisson
B	Seitenblech	Side plate	Tôle laterale
B1	Abstellstütze	Stand	Bequille
C	Stab- und Zahnwalzen	Rollers	Rouleaux
C1	Gefederte Walzenabstützung	Spring tension	Rouleau monté sur ressort
C2	Polygonwalze	Polygon roller	Rouleau polygone
D	Antrieb	Drive	Entrainement
D1	Schnellwechselsystem	Quick-Fit tines	Kit de demontage rapide
E	Wechselradgetriebe	Gearbox	Boîtier de vitesse
E1	Wechselradgetr. mit Durchtr.	Gearbox with PTO through drive	Boîtier de vitesse avec prise de force arr.
E2	Schutz f. Durchtr.	Cover	Protection
F	Englandschutz	Protection -GB-	Protection -GB-
G	Prallblech	Clod bar	Chicane
H	Träger für Radspurlockerer	Bracket for eradicator	Support pour effaceur
J	Radspurlockerer	Eradicator	Effaceur de trace
K	Leitblech	Deflector	Deflecteur
L	Dreipunktgestänge mechan.	Rear hitch mechan.	Attelage 3-points mechan.
M	Drill-Lift	Drill-Lift	Drill-Lift
N	Hydraulischer Aushub	Hydraulic lifting	Relevage hydraulique
O	Zylinder (hydr.Aushub)	Cylinder (hydr.lifting)	Verin (relevage hydr.)
P	Hubbegrenzung	Lift limiter	Butée de limit.de course
R	Satteldreieck	A-frame (male)	Triangle d'attelage
S	Beleuchtungseinrichtung	Rear light kit	Kit d'éclairage
T	Segment-Schutzschiene hinten	Protection bar rear	Barre de protection arrière

Corvus PKE Br.5, Corvex P Br.6

U	Aufbausatz für ME(L)-A	Hitch for ME(L)-A	Kit adaption pour ME(L)-A
V	Frontanbau	Front mounting	Montage poussée

2213_A

Turm, Werkzeugträger
Headstock, trough
Tête, caisson

Corvus PKE Br.5, Corvex P Br.6

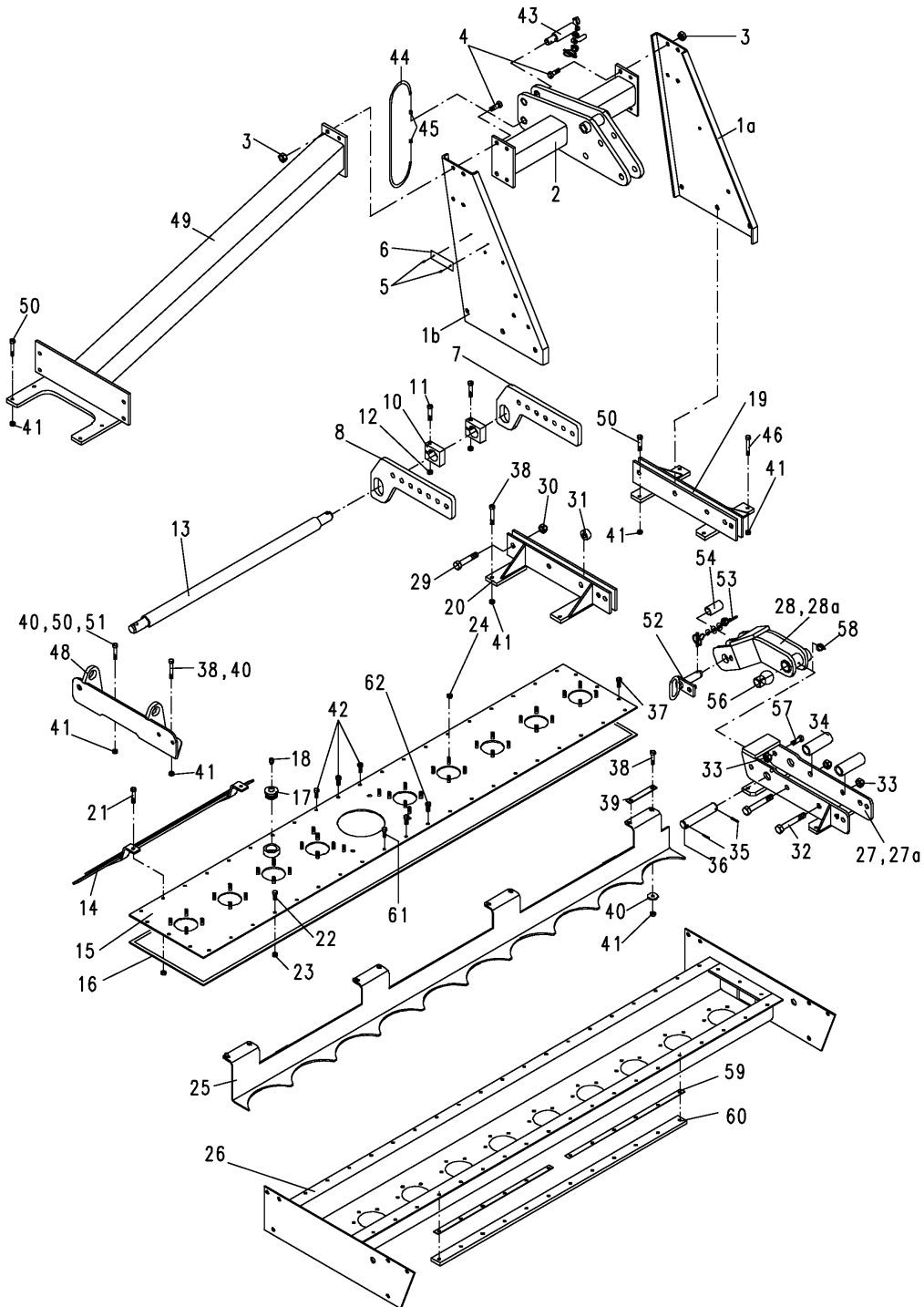

2213_A

 Turm, Werkzeugträger
 Headstock, trough
 Tête, caisson

Corvus PKE Br.5, Corvex P Br.6

Bild Ref. Fig.	Bestellnr. Part-No. Référence	Stck. Qty. Qte.	Bezeichnung	Technische Angaben Technical data Données techniques	Description	Désignation
1a	8435.20.04	1	Turmblech, rechts		Headstock r.h.	Tôle potence droit
1b	8435.20.03	1	Turmblech, links		Headstock l.h.	Tôle potence gauche
2	8435.21.01	1	Turmverbindung		Connecter	Assemblage
3	8405.00.18	8	Poly-Stop-Sechskantmutter	M16x1,5	Poly-Stop nut	Ecrou Poly-Stop
4	960D161545N A	8	Sechskantschraube	M16x1,5x45 DIN960-10.9 vz.	Hex. bolt	Vis 6 pans
4	960D161560M	8	Sechskantschraube	M16x1,5x60 DIN960-12.9	Hex. bolt	Vis 6 pans
5	1476D410	2	Halbrundkerbnagel	4x10 DIN1476	Rivet	Rivet
6	1000.99.01	1	Typenschild		ID-plate	ID-plaque
7	8435.19.10	1	Anschlußschiene		Connecting rail	Porte à visser
8	8435.19.05	1	Anschlußstück		Connecting bracket r.h.	Support à visser, droit
10	8413.00.41	2	Klemmstück		Clamp plate	Pièce de serrage
11	931D1280M	2	Sechskantschraube	M12x80 DIN931-12.9	Hex. bolt	Vis 6 pans
12	934D12M	2	Sechskantmutter	M12 DIN934-12	Hex. nut	Ecrou 6 pans
13	8406.28.00	1	Dreipunktachse	Kat.3 kurz (short/court)	3-point shaft	Axe 3-points
13	8007.17.05	1	Dreipunktachse	Kat.3, DA-75	3-point shaft	Axe 3-points
13	8007.17.02	1	Dreipunktachse	Kat.2, DA-793	3-point shaft	Axe 3-points
14	8437.61.03	1	Beinschutz, links	3,0 m	Safety cover	Protecteur
14	8437.61.04	1	Beinschutz, rechts	3,0 m	Safety cover r.h.	Protecteur droit
14	8437.61.07	1	Beinschutz, links	4,0 m	Safety cover	Protecteur
14	8437.61.08	1	Beinschutz, rechts	4,0 m	Safety cover r.h.	Protecteur droit
14	8437.61.09	1	Beinschutz, links	4,5 m	Safety cover	Protecteur
14	8437.61.10	1	Beinschutz, rechts	4,5 m	Safety cover r.h.	Protecteur droit
15	8427.39.06	1	Abdeckblech	3,0 m	Endcap	Couvercle
15	8427.39.07	1	Abdeckblech	4,0 m	Endcap	Couvercle
15	8427.39.05	1	Abdeckblech	4,5 m	Endcap	Couvercle
16	8409.31.09	1	Flachdichtung	3,0 m	Seal	Joint
16	8409.31.10	1	Flachdichtung	4,0 m	Seal	Joint
16	8409.31.16	1	Flachdichtung	4,5 m	Seal	Joint
17	8404.24.00	1	Verschußschraube	R 1 1/2"	Hexagon head plug	Bouchon fileté
18	8404.47.00	1	Be- und Entlüftungsfilter		Breather	Reniflard
19	8435.11.02	1	Turmhalterung, rechts		Bracket, r.h.	Support, droit
20	8435.11.01	1	Turmhalterung, links		Bracket, l.h.	Support, gauche
21	933D1235N		Sechskantschraube	M12x35 DIN933-10.9	Hex. bolt	Vis 6 pans
22	933D1225N		Sechskantschraube	M12x25 DIN933-10.9	Hex. bolt	Vis 6 pans
23	980DV12NA		Sicherungsmutter	VM12 DIN980-10 vz.	Lock nut	Ecrou frein
24	980DV10NA		Sicherungsmutter	VM10 DIN980-10 vz.	Lock nut	Ecrou frein
25	8435.18.03	1	Schutzschiene, links	3,0 m	Protection bar l.h.	Barre de protect. gauche

2213_A

Turm, Werkzeugträger
Headstock, trough
Tête, caisson

Corvus PKE Br.5, Corvex P Br.6

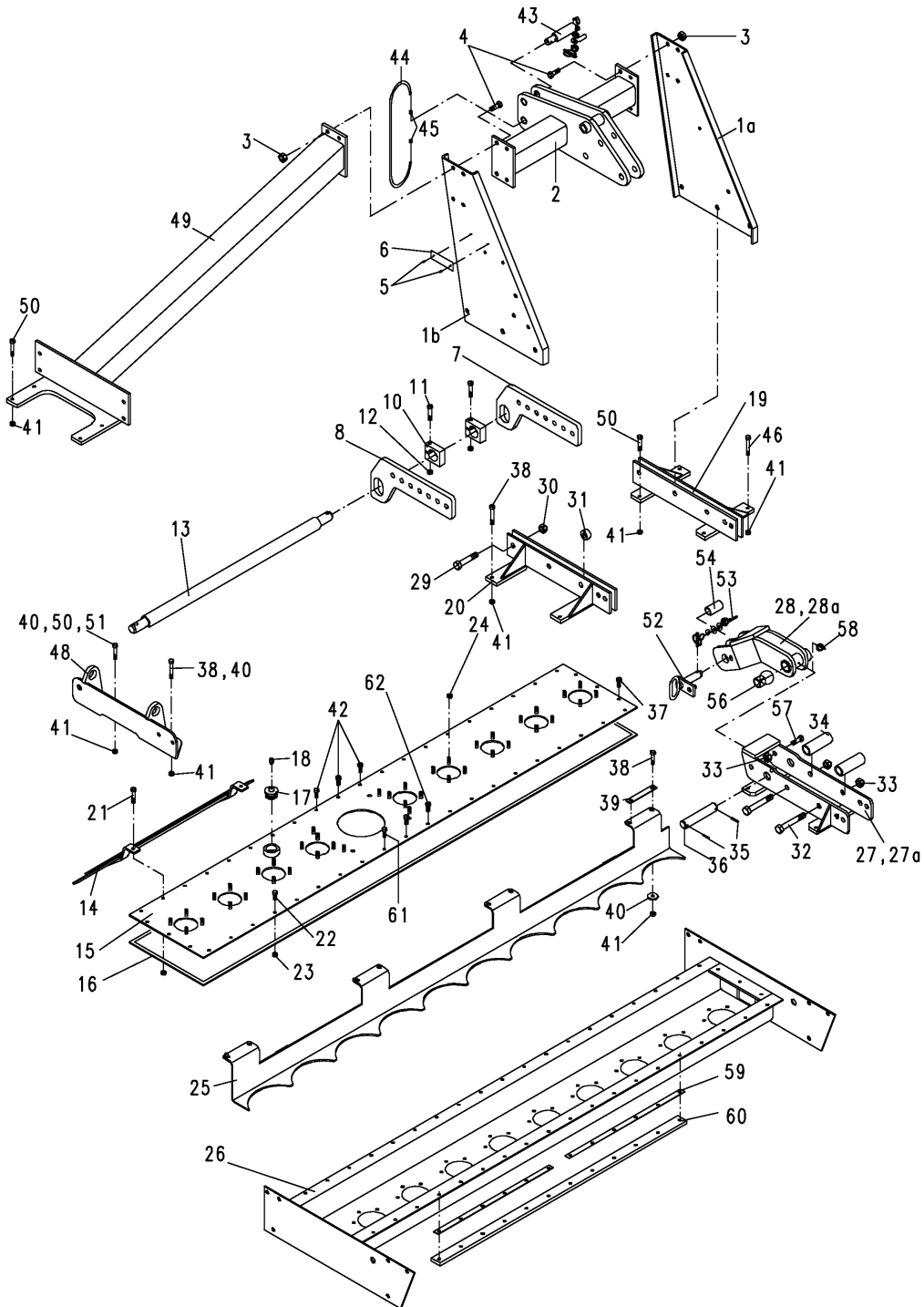

2213_A

 Turm, Werkzeugträger
 Headstock, trough
 Tête, caisson

Corvus PKE Br.5, Corvex P Br. 6

Bild Ref. Fig.	Bestellnr. Part-No. Référence	Stck. Qty. Qte.	Bezeichnung	Technische Angaben Technical data Données techniques	Description	Désignation
25	8435.18.07	1	Schutzschiene, vorn li.	4,0m	Rear protection front l.h.	Barre de protection avant gauche
25	8435.18.08	1	Schutzschiene, vorn re.	4,0m	Rear protection front r.h.	Barre de protection avant droite
25	8435.18.09	1	Schutzschiene, vorn li.	4,5m	Rear protection front l.h.	Barre de protection avant gauche
25	8435.18.10	1	Schutzschiene, vorn re.	4,5m	Rear protection front r.h.	Barre de protection avant droite
26	8437.58.02	1	Werkzeugträger	3,0 m	Trough	Caisson
26	8437.58.04	1	Werkzeugträger	4,0 m	Trough	Caisson
26	8437.58.05	1	Werkzeugträger	4,5 m	Trough	Caisson
27	8437.68.01	1	Turmhalterung, li.		Bracket, l.h.	Support, gauche
27a	8437.68.02	1	Turmhalterung, re.		Bracket, r.h.	Support, droit
28	8437.69.01	1	Anlenkung, re.		Link arm r.h.	Bras réglable droit
28a	8437.69.02	1	Anlenkung, li.		Link arm l.h.	Bras réglable gau.
29	960D201570N	6	Sechskantschraube	M20x1,5x70 -10.9	Hex. bolt	Vis 6 pans
30	980DV2015N	6	Sicherungsmutter	VM20x1,5-10.9	Lock nut	Ecrou frein
32	931D20180P	4	Sechskantschraube	M20x180 -8.8	Hex. bolt	Vis 6 pans
33	980DV20PA	6	Sicherungsmutter	VM20	Lock nut	Ecrou frein
34	SR33745X121	4	Rohr	L=121	Pipe	Tube
35	1000.14.01	2	Bolzen		Pin	Axe
36	1481D850A	4	Spannstift	8x50	Dowel Pin	Goupille serrage
37	8426.13.07		Verbus-Ripp 6ktschr.	M12x30-100	Bolt	Vis
38	933D1245M	4	Sechskantschraube	M12x45 -12.9	Hex. bolt	Vis 6 pans
39	8411.00.29	4	Unterlage		Shim	Cale
40	6436.60.03		Scheibe	C-13	Washer	Rondelle
41	980DV12M		Sicherungsmutter	VM12	Lock nut	Ecrou frein
42	933D1240N	3	Sechskantschraube	M12x40 -10.9	Hex. bolt	Vis 6 pans
43	8413.31.00	1	OBERLENKERSTOCK	Kat.2	TOP LINK PIN	AXE 3 POINTS
43	8413.58.00	1	OBERLENKERSTOCK	Kat.3	TOP LINK PIN	AXE 3 POINTS
44	8405.00.19	1	Bügel		Fastener	Support
45	8405.00.34	2	Lamellenstopfen		Plug	Bouchon
46	931D1265M	6	Sechskantschraube	M12x65 -12.9	Hex. bolt	Vis 6 pans
48	8437.60.01	1	Seitenblechträger, links		Bracket l.h.	Support gauche
48	8437.60.02	1	Seitenblechträger, rechts		Bracket r.h.	Support droit
49	8435.22.01	1	Turmabstützung, li.	4,0 m	Strut l.h.	Support gauche
49	8435.22.02	1	Turmabstützung, re.	4,0 m	Strut r.h.	Support droit
50	931D1255M	4	Sechskantschraube	M12x55 -12.9	Hex. bolt	Vis 6 pans
52	8432.75.01	2	U.L.-Bolzen	Kat.2/3	Lower link pin	Piton interieur
53	6344.40.03	2	Sicherungskette kpl.		Safety chain cpl.	Chainette de securité cpl.
54	8432.45.01	2	Reduzierbuchse	65-28/36x50	Bush	Baque

2213_A

Turm, Werkzeugträger
Headstock, trough
Tête, caisson

Corvus PKE Br.5, Corvex P Br.6

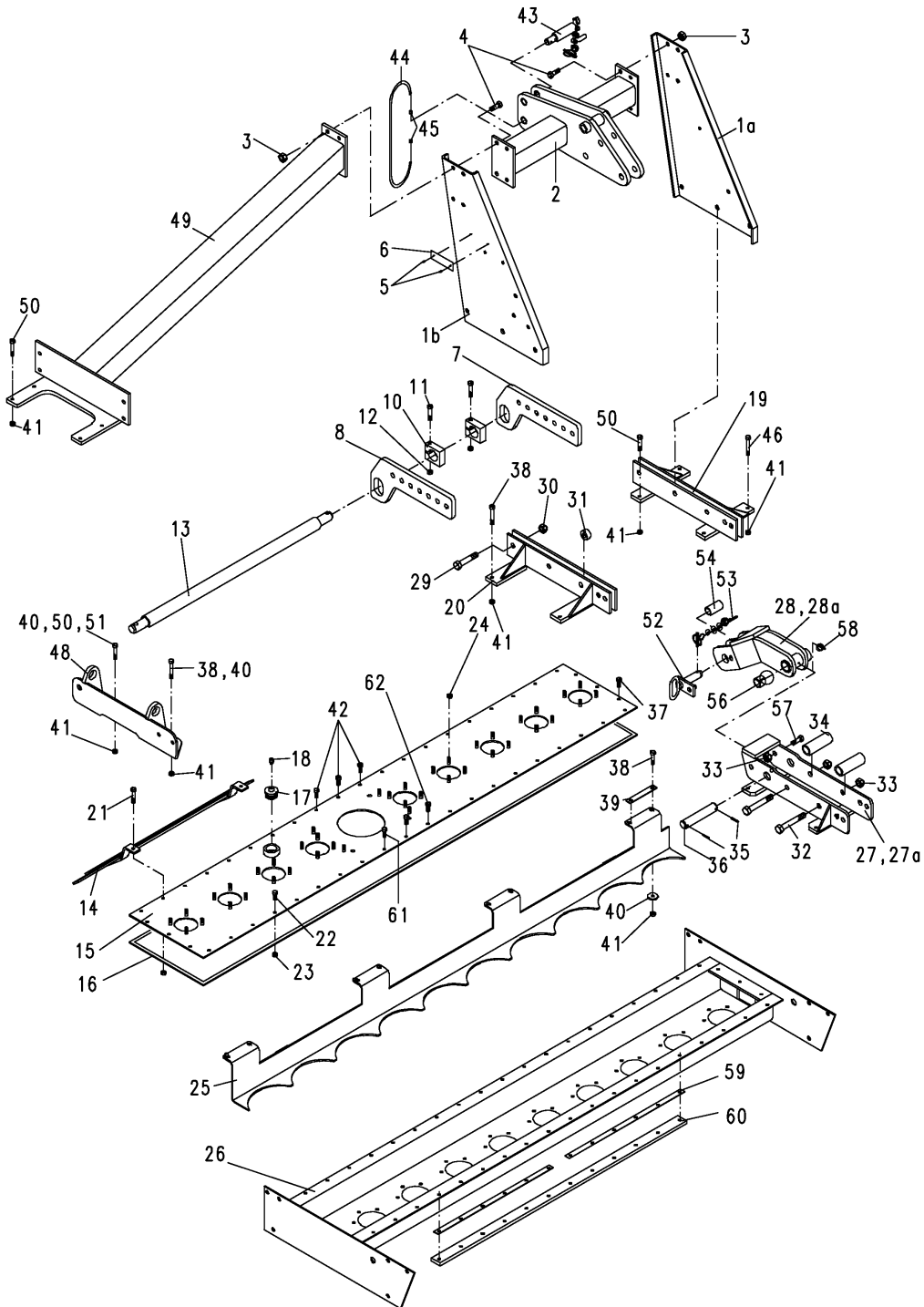

2213_A

 Turm, Werkzeugträger
 Headstock, trough
 Tête, caisson

Corvus PKE Br.5, Corvex P Br.6

Bild Ref. Fig.	Bestellnr. Part-No. Référence	Stck. Qty. Qte.	Bezeichnung	Technische Angaben Technical data Données techniques	Description	Désignation
54	8432.45.01	2	Reduzierbuchse	65-28/36x50	Bush	Baque
56	1498D354030	4	Buchse	EG 35/40x30 DIN1498	Bush	Douille
57	933D2045P	2	Sechskantschraube	M20x45 DIN933-8.8	Hex. bolt	Vis 6 pans
58	4716.43.00	2	Schmiernippel	H2 8x1 KX-2	Grease nipple	Graisneur
59	8437.00.61	2	Unterlage		Shim	Cale
60	8437.00.60	1	Leiste		Strip	Listeau
61	931D1250P	2	Sechskantschraube	M12x50 DIN931-8.8	Hex. bolt	Vis 6 pans
62	931D1255N	1	Sechskantschraube	M12 x 55 DIN931-10.9	Hex. bolt	Vis 6 pans
63			Zinkenträger, lang rechts	3,0m	Harrow bar long r.h.	Support de dente long droit

2213_B

Seitenblech
Side plate
Tôle laterale

Corvus PKE Br.5, Corvex P Br.6

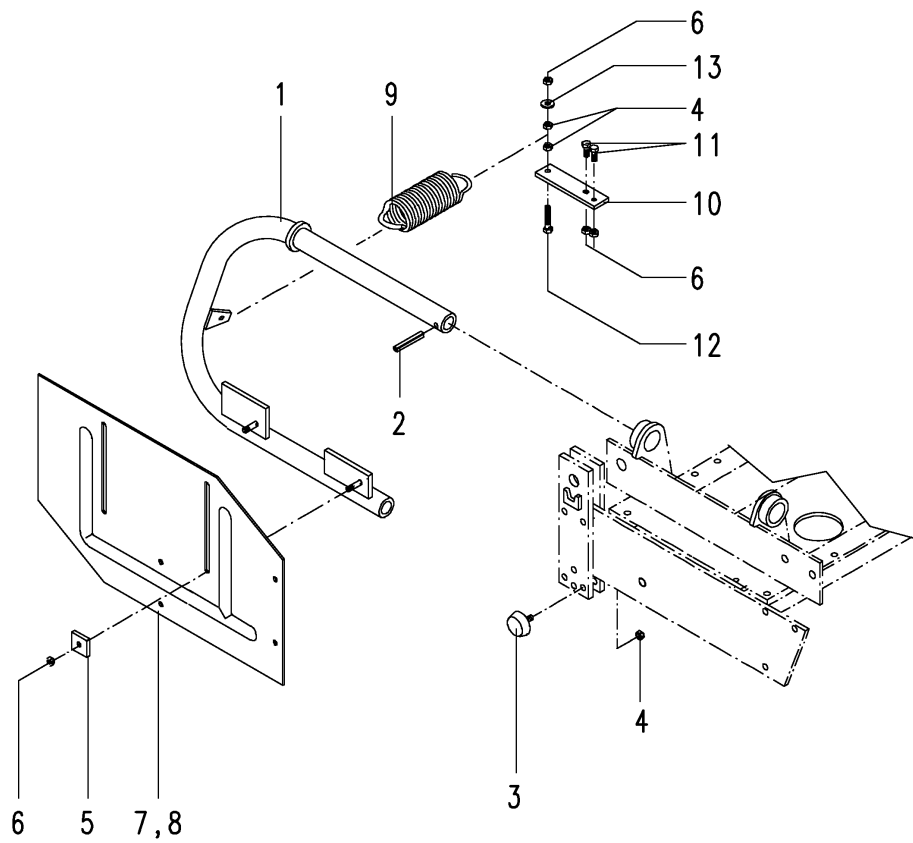

2213_B

 Seitenblech
 Side plate
 Tôle laterale

Corvus PKE Br.5, Corvex P Br.6

Bild Ref. Fig.	Bestellnr. Part-No. Référence	Stck. Qty. Qte.	Bezeichnung	Technische Angaben Technical data Données techniques	Description	Désignation
	8432.68.01	1	SEITENBLECH KPL.		SIDE PLATE CPL.	TOLE LATERALE CPL.
1	8432.67.01	1	Seitenblechträger -links-		Side plate arm l.h.	Bras de tôle laterale gauche
1	8432.67.02	1	Seitenblechträger -rechts-		Side plate arm r.h.	Bras de tôle laterale droit
2	1481D850	2	Spannstift	8x50 DIN1481	Dowel Pin	Goupille serrage
3	8432.00.30	2	Anschlagpuffer		Limiter	Battée
4	934D10PA	6	Sechskantmutter	M10 DIN934-8 vz.	Hex. nut	Ecrou 6 pans
5	6436.60.03	4	Scheibe	C-13	Washer	Rondelle
6	980DV10PA	10	Sicherungsmutter	VM10 DIN980-8 vz.	Lock nut	Ecrou frein
7	8413.86.01	1	Seitenblech, links		Side plate l.h.	Tôle laterale gauche
8	8413.86.02	1	Seitenblech, rechts		Side plate r.h.	Tôle laterale droit
9	6334.09.05	2	Zugfeder	CF-292	Tension spring	Ressort
10	8432.68.02	2	Hebel		Lever	Levier
11	933D1035PA	4	Sechskantschraube	M10x35 DIN933-8.8 vz.	Hex. bolt	Vis 6 pans
12	933D1050PA	2	Sechskantschraube	M10x50 DIN933-8.8 vz.	Hex. bolt	Vis 6 pans
13	440DR11A	2	Scheibe	R11 DIN440 vz.	Washer	Rondelle
14			Zinkenträger, lang rechts	3,0m	Harrow bar long r.h.	Support de dente long droit

2213_B1

Abstellstütze
Stand
Bequille

Corvus PKE Br.5, Corvex P Br.6

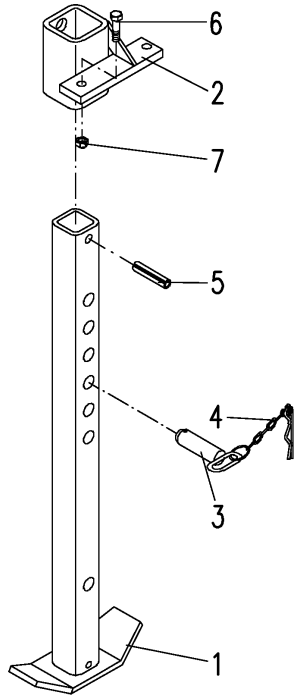

2213_B1

 Abstellstütze
 Stand
 Bequille

Corvus PKE Br.5, Corvex P Br.6

Bild Ref. Fig.	Bestellnr. Part-No. Référence	Stck. Qty. Qte.	Bezeichnung	Technische Angaben Technical data Données techniques	Description	Désignation
1-6	8437.65.01	1	ABSTELLSTÜTZE KPL.		STAND CPL.	BEQUILLE CPL.
1	8431.31.01	1	Abstellstütze		Stand	Bequille
2	8437.66.01	1	Stützenhalter		Bracket	Support
3+4	7212.05.03	1	STECKSTOCK KPL.		PIN CPL.	AXE CPL.
3	7212.05.00	1	Steckstock		Pin	Axe
4	6344.40.08	1	Sicherungskette kpl.		Safety chain cpl.	Chainette de sécurité cpl.
5	1481D1360	1	Spannstift	13x60 DIN1481	Dowel Pin	Goupille serrage
6	931D1255M	2	Sechskantschraube	M12x55 DIN931-12.9	Hex. bolt	Vis 6 pans
7	980DV12NA	2	Sicherungsmutter	VM12 DIN980-10 vz.	Lock nut	Ecrou frein

2213_C

Stab- und Zahnwalzen
Rollers
Rouleaux

Corvus PKE Br.5, Corvex P Br.6

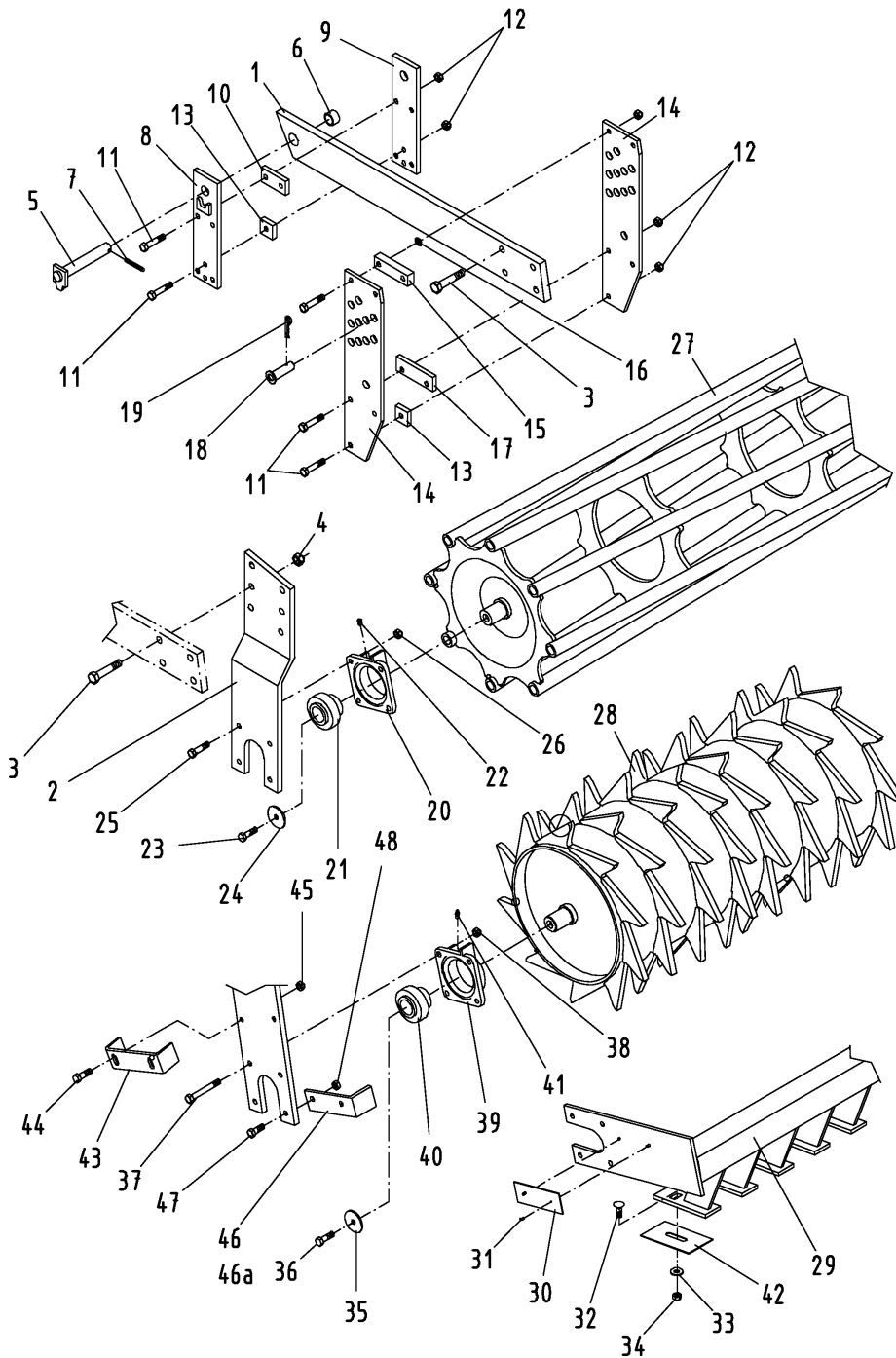

2213_C

 Stab- und Zahnwalzen
 Rollers
 Rouleaux

Corvus PKE Br.5, Corvex P Br.6

Bild Ref. Fig.	Bestellnr. Part-No. Référence	Stck. Qty. Qte.	Bezeichnung	Technische Angaben Technical data Données techniques	Description	Désignation
1	8435.00.52	2	Stellarm		Lever	Levier de réglage
2	8437.78.02	1	Lagerarm, links	3,0m - 4,5m	Roller arm l.h.	Bras de palier gauche
2	8437.78.03	1	Lagerarm, rechts	3,0m - 4,5m	Roller arm r.h.	Bras de palier droit
3	960D161560M	8	Sechskantschraube	M16x1,5x60 DIN960-12.9	Hex. bolt	Vis 6 pans
4	8405.00.18	8	Poly-Stop-Sechskantmutter	M16x1,5	Poly-Stop nut	Ecrou Poly-Stop
5	8018.66.02	2	Bolzen		Pin	Axe
6	1498D253220	2	Buchse	EG 25/32x20 DIN1498	Bush	Douille
7	1481D840A	2	Spannstift	8x40 DIN1481 vz.	Dowel Pin	Goupille serrage
8	8432.12.01	2	Führungsplatte, außen		Outer plate	Plaque extérieur
9	8432.12.02	2	Platte		Plate	Plaque
10	8432.00.19	2	Distanzstück		Spacer	Entretoise
11	931D1260N	16	Sechskantschraube	M12x60 DIN931-10.9	Hex. bolt	Vis 6 pans
12	980DV12NA	16	Sicherungsmutter	VM12 DIN980-10 vz.	Lock nut	Ecrou frein
13	8432.00.18	4	Distanzstück		Spacer	Entretoise
14	8437.00.40	4	Stelleiste		Arm	Bras
15	8433.00.11	2	Lasche		Latch	Plat
16	126D14	4	Scheibe	14 DIN126	Washer	Rondelle
17	8433.00.12	2	Distanzstück		Spacer	Entretoise
18	8404.45.00	2	Steckstock verzinkt		Pin	Axe
19	4716.35.00	2	Federsteckstock	BTB-4	R-dip	Goupille beta
20-22	8432.23.01	2	FLANSCHLAGER KPL.	Di= Ø40 mm	BEARING CPL.	PALIER CPL.
20	8432.23.02	2	Flanschlager		Bearing	Palier
21	8432.23.03	2	Spannlager	GNVE 40KRRBCC	Bearing	Roulement
22	71412DA81	2	Schmiernippel	AM8x1 DIN71412	Grease nipple	Graisseur
23	933D1235N	2	Sechskantschraube	M12x35 DIN933-10.9	Hex. bolt	Vis 6 pans
24	8432.00.34	2	Scheibe		Washer	Rondelle
25	931D1245N	8	Sechskantschraube	M12x45 DIN931-10.9	Hex. bolt	Vis 6 pans
26	980DV12NA	8	Sicherungsmutter	VM12 DIN980-10 vz.	Lock nut	Ecrou frein
27	8406.19.05	1	Stabpackerwalze	3,0m Ø440	Crumbler roller	Rouleau à barres
27	8406.74.19	1	Stabpackerwalze	3,0m Ø540	Crumbler roller	Rouleau à barres
27	8404.41.00	1	Stabpackerwalze	4,0m Ø440	Crumbler roller	Rouleau à barres
28	6810.01.10	1	Zahnpackerwalze	GZW 510/3,0m	Packer roller	Rouleau packer
28	6810.01.05	1	Zahnpackerwalze	GZW 510/4,0m	Packer roller	Rouleau packer
28	6810.01.06	1	Zahnpackerwalze	GZW 510/4,5m	Packer roller	Rouleau packer
29	8406.53.35	1	Abstreifer	GZW 510/3,0m	Scraper	Décrottoir
29	8406.53.04	1	Abstreifer	GZW 510/4,0m	Scraper	Décrottoir
29	8406.53.29	1	Abstreifer	GZW 510/4,5m	Scraper	Décrottoir
30	4716.37.00	1	Typenschild	SX-4	ID-plate	ID-plaque

2213_C

Stab- und Zahnwalzen
 Rollers
 Rouleaux

Corvus PKE Br.5, Corvex P Br.6

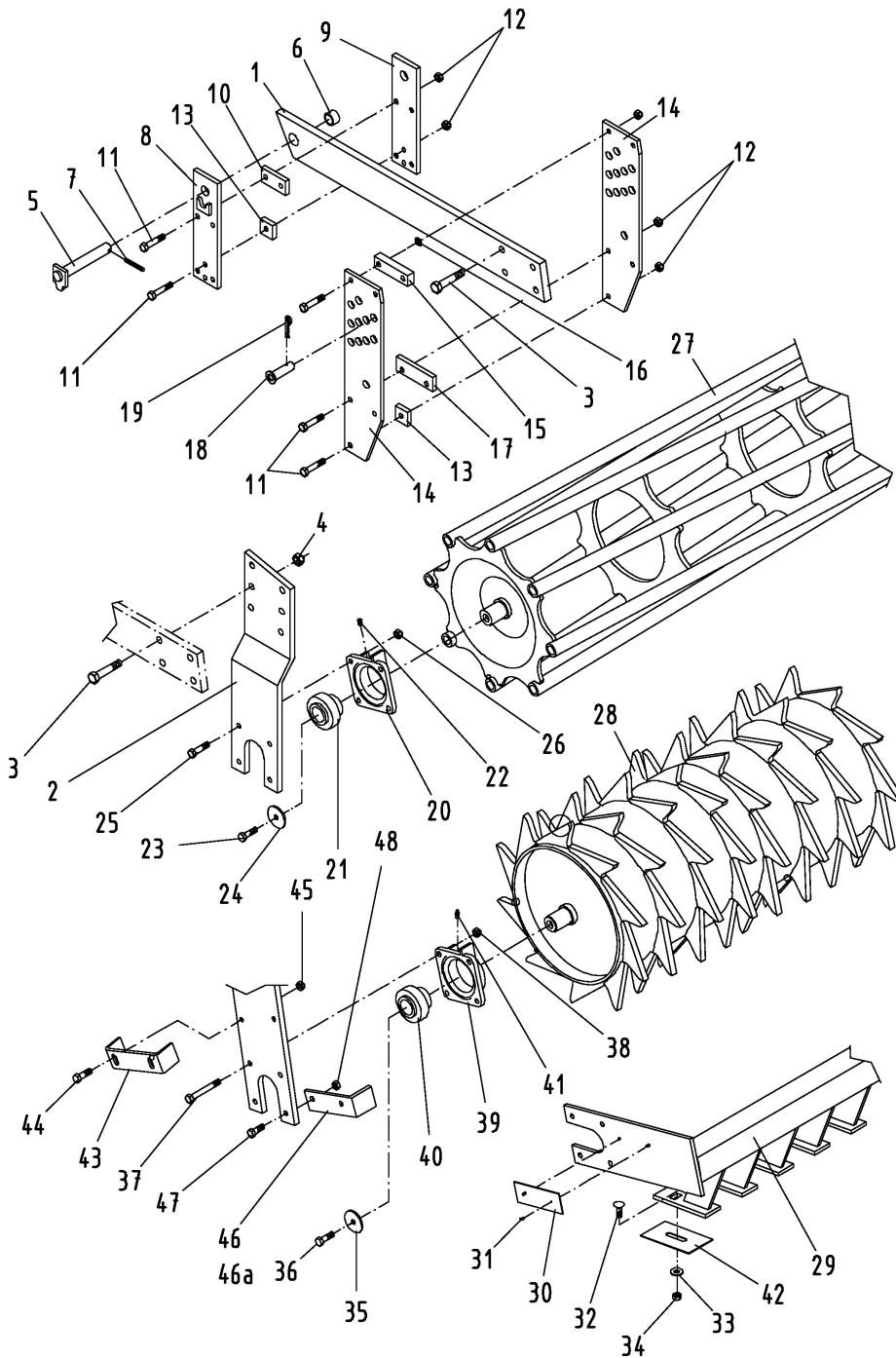

2213_C

 Stab- und Zahnwalzen
 Rollers
 Rouleaux

Corvus PKE Br.5, Corvex P Br.6

Bild Ref. Fig.	Bestellnr. Part-No. Référence	Stck. Qty. Qte.	Bezeichnung	Technische Angaben Technical data Données techniques	Description	Désignation
31	1476D410	2	Halbrundkerbnagel	4x10 DIN1476	Rivet	Rivet
32	603D1230PA	24,3	Flachrundschraube	M12x30 DIN603-8.8 vz.	Bolt	Vis
33	7349D13A	24,3	Scheibe	13 DIN7349 vz.	Washer	Rondelle
34	934D12PA	24,3	Sechskantmutter	M12 DIN934-8 vz.	Hex. nut	Ecrou 6 pans
35	8434.29.09	2	Scheibe		Washer	Rondelle
36	933D1235N	2	Sechskantschraube	M12x35 DIN933-10.9	Hex. bolt	Vis 6 pans
37	931D1290N	8	Sechskantschraube	M12x90 DIN931-10.9	Hex. bolt	Vis 6 pans
38	980DV12NA	8	Sicherungsmutter	VM12 DIN980-10 vz.	Lock nut	Ecrou frein
39-41	8434.29.01	2	FLANSCHLAGER KPL.	Di= Ø55 mm	BEARING CPL.	PALIER CPL.
39	8434.29.02	2	Flanschlager		Bearing	Palier
40	8434.29.03	2	Spannlager	PDFN 160-55-26	Bearing	Roulement
41	71412DB81	2	Schmiernippel	BM8x1 DIN71412	Grease nipple	Graisseur
42	8405.00.27	24,3	Abstreiferblech		Scraper plate	Tôle de décrottoir
42	8406.00.09	24,3	Abstreiferblech hartbeschicht.	GZW 510	Scraper plate hard coated	Tôle de décrottoir dur
43	8434.49.15	2	Seitenabstreifer	GZW	Scraper	Décrottoir
43	8434.49.16	2	Seitenabstreifer, hartbeschicht.	GZW	Scraper hard coated	Décrottoir dur
44	933D1235NA	4	Sechskantschraube	M12x35 DIN933-10.9 vz.	Hex. bolt	Vis 6 pans
45	980DV12NA	4	Sicherungsmutter	VM12 DIN980-10 vz.	Lock nut	Ecrou frein
46-48	8434.56.01	1	INNENABSTREIFER	GZW	SCRAPER CPL.	DECROTTOIR CPL.
46	8434.55.01	1	Abstreifer, links		Scraper l.h.	Barre décrott. gauche
46a	8434.55.02	1	Abstreifer, rechts		Scraper r.h.	Barre décrott. droit
47	933D1240P	4	Sechskantschraube	M12x40 DIN933-8.8	Hex. bolt	Vis 6 pans
48	980DV12PA	4	Sicherungsmutter	VM12 DIN980-8 vz.	Lock nut	Ecrou frein

2213_C1

Gefederte Walzenabstützung
Spring tension
Rouleau monté sur ressort

Corvus PKE Br.5, Corvex P Br.6

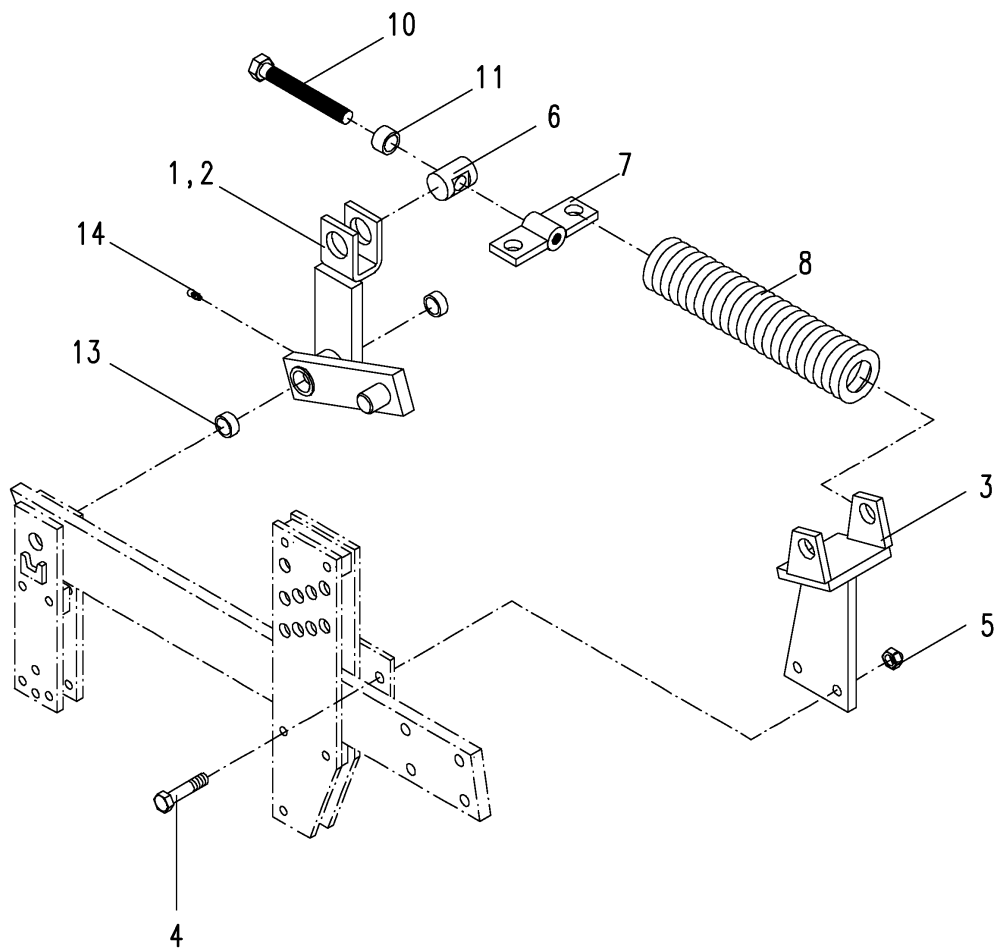

2213_C1

 Gefederte Walzenabstützung
 Spring tension
 Rouleau monté sur ressort

Corvus PKE Br.5, Corvex P Br.6

Bild Ref. Fig.	Bestellnr. Part-No. Référence	Stck. Qty. Qte.	Bezeichnung	Technische Angaben Technical data Données techniques	Description	Désignation
1	8432.89.01	1	Federhalter, vorn links		Front springholder l.h.	Support avant gauche
2	8432.89.02	1	Federhalter, vorn rechts		Front springholder r.h.	Support avant droit
3	8432.88.01	2	Federhalter, hinten		Springholder rear	Support de ressort arr.
4	960D161550N	4	Sechskantschraube	M16x1,5x50 DIN960-10.9	Hex. bolt	Vis 6 pans
5	8405.00.18	4	Poly-Stop-Sechskantmutter	M16x1,5	Poly-Stop nut	Ecrou Poly-Stop
6	6329.00.01	2	Spindellager	LB-53	Spindle guide	Palier
7	8413.65.00	2	Federspanner	2 Fed.(springs/ressorts)	Tensioner	Tendeur
8	8404.30.11	4	Zugfeder	CF-314	Tension spring	Ressort
10	933D20200P	2	Sechskantschraube	M20x200 DIN933-8.8	Hex. bolt	Vis 6 pans
11	8411.88.01	2	Distanzrohr		Spacer	Entretoise
13	1498D253214	4	Buchse	EG 25/32x14 DIN1498	Bush	Douille
14	4716.38.00	2	Schmiernippel	H1 8x1 KX-1	Grease nipple	Graisseur

2213_C2

Polygonwalze
Polygon roller
Rouleau polygone

Corvus PKE Br.5, Corvex P Br.6

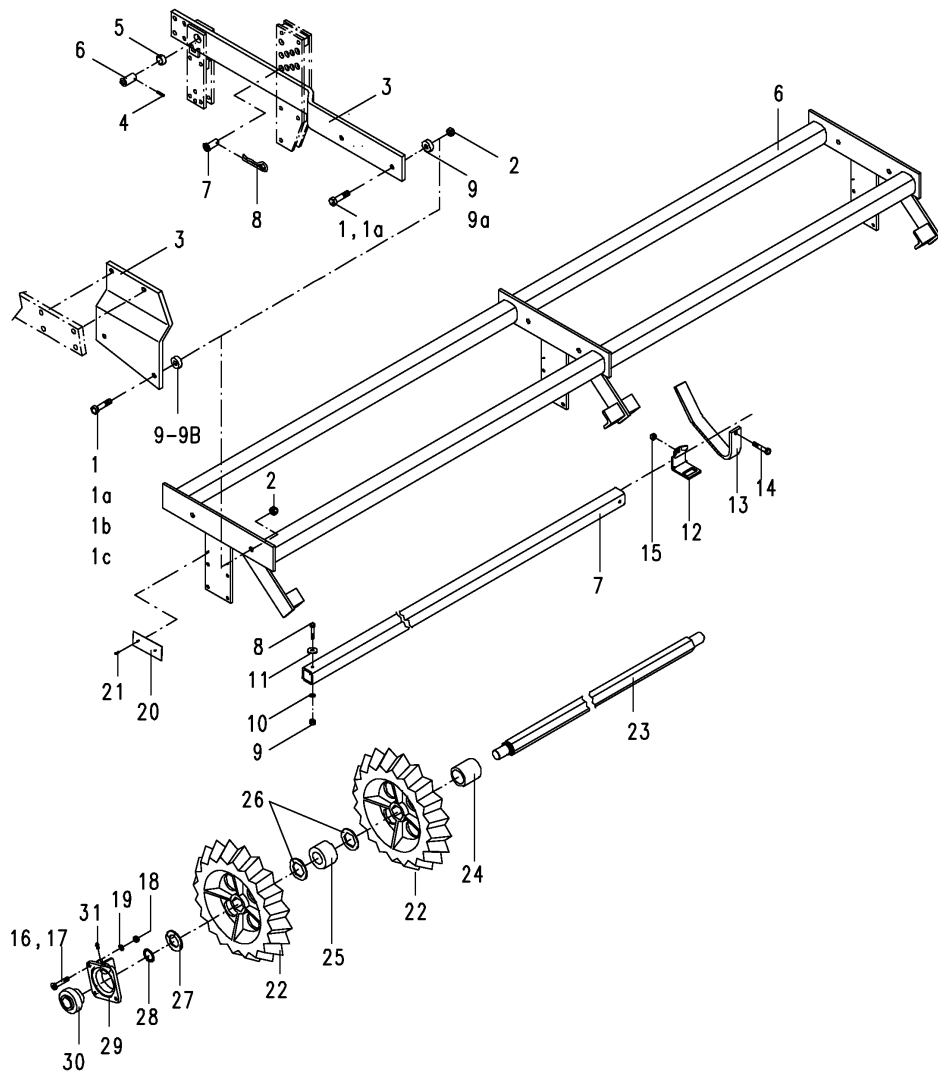

2213_C2

 Polygonwalze
 Polygon roller
 Rouleau polygone

Corvus PKE Br.5, Corvex P Br.6

Bild Ref. Fig.	Bestellnr. Part-No. Référence	Stck. Qty. Qte.	Bezeichnung	Technische Angaben Technical data Données techniques	Description	Désignation
1-9	6809.26.01	1	SEITENARME KPL.	MKE/PKE 2,0 M-4,0 M	SIDE ARMS CPL.	BRAS LATÉRALE CPL.
1a-9a	6809.26.02	1	SEITENARME KPL.	MKE/PKE 4,5 M	SIDE ARMS CPL.	BRAS LATÉRALE CPL.
1	933D1645P	4	Sechskantschraube	M16x45 DIN 933-8.8	Hex. bolt	Vis 6 pans
1a	931D1660P	4	Sechskantschraube	M16x60 DIN931-8.8	Hex. bolt	Vis 6 pans
2	980DV16P	4	Sicherungsmutter	VM16 DIN980-8	Lock nut	Ecrou frein
3	6809.27.01	1	Seitenarm, rechts		Side arm r.h.	Bras laterale droit
3	6809.27.02	1	Seitenarm, links		Side arm l.h.	Bras laterale gauche
4	1481D636A	2	Spannstift	6x36 DIN1481 vz.	Dowel Pin	Goupille serrage
5	1498D253214	2	Buchse	EG 25/32x14 DIN1498	Bush	Douille
6	8409.99.01	2	Steckstock		Pin	Axe
7	8409.99.02	2	Steckstock		Pin	Axe
8	4716.35.00	2	Federsteckstock	BTB-4	R-clip	Goupille beta
9	6809.14.03	4	Distanzplatte	L=8 mm	Spacer plate	Entretoise
9a	6809.14.02	4	Distanzplatte	L=10 mm	Spacer plate	Entretoise
1-3	6809.26.05	1	LAGERARME KPL.	CKE, VKE, HKE 3,0 M	ROLLER ARMS CPL.	BRAS DE PALIER CPL.
1a-9b	6809.26.06	1	LAGERARME KPL.	CKE, VKE, HKE 4,0 M	ROLLER ARMS CPL.	BRAS DE PALIER CPL.
1b-9a	6809.26.07	1	LAGERARME KPL.	CKE, VKE, HKE 4,5 M	ROLLER ARMS CPL.	BRAS DE PALIER CPL.
1a-9b	6809.26.08	1	LAGERARME KPL.	CKE, VKE, HKE 5,0 M	ROLLER ARMS CPL.	BRAS DE PALIER CPL.
1c-9a,b	6809.26.09	1	LAGERARME KPL.	CKE, VKE, HKE 6,0 M	ROLLER ARMS CPL.	BRAS DE PALIER CPL.
1	933D1645P	4	Sechskantschraube	M16x45 DIN 933-8.8	Hex. bolt	Vis 6 pans
1a	931D1660P	4	Sechskantschraube	M16x60 DIN931-8.8	Hex. bolt	Vis 6 pans
1b	931D1665P	4	Sechskantschraube	M16x65 DIN931-8.8	Hex. bolt	Vis 6 pans
1c	931D1670P	4	Sechskantschraube	M16x70 DIN931-8.8	Hex. bolt	Vis 6 pans
2	980DV16P	4	Sicherungsmutter	VM16 DIN980-8	Lock nut	Ecrou frein
3	6809.57.01	1	Lagerarm, links	3,0 m	Roller arm l.h.	Bras de palier gauche
3	6809.57.02	1	Lagerarm, rechts	3,0 m	Roller arm r.h.	Bras de palier droit
3	6809.29.01	1	Lagerarm, links	4,0 m-6,0 m	Roller arm l.h.	Bras de palier gauche
3	6809.29.02	1	Lagerarm, rechts	4,0 m-6,0 m	Roller arm r.h.	Bras de palier droit
9a	6809.14.02	4	Distanzplatte	L=10 mm	Spacer plate	Entretoise
9b	6809.14.01	4	Distanzplatte	L=15 mm	Spacer plate	Entretoise
6	6809.24.02	1	Tragrahmen	2,5 m	Bracket	Support
6	6809.24.03	1	Tragrahmen	3,0 m	Bracket	Support
6	6809.24.05	1	Tragrahmen	4,0 m	Bracket	Support
6	6809.24.06	1	Tragrahmen	4,5 m	Bracket	Support
6	6809.24.07	1	Tragrahmen	5,0 m	Bracket	Support
6	6809.24.08	1	Tragrahmen	6,0 m	Bracket	Support
7	6809.05.01	1	Abstreiferschiene	1,50 m	Scraper rail	Porte decrotoir

2213_C2

Polygonwalze
 Polygon roller
 Rouleau polygone

Corvus PKE Br.5, Corvex P Br.6

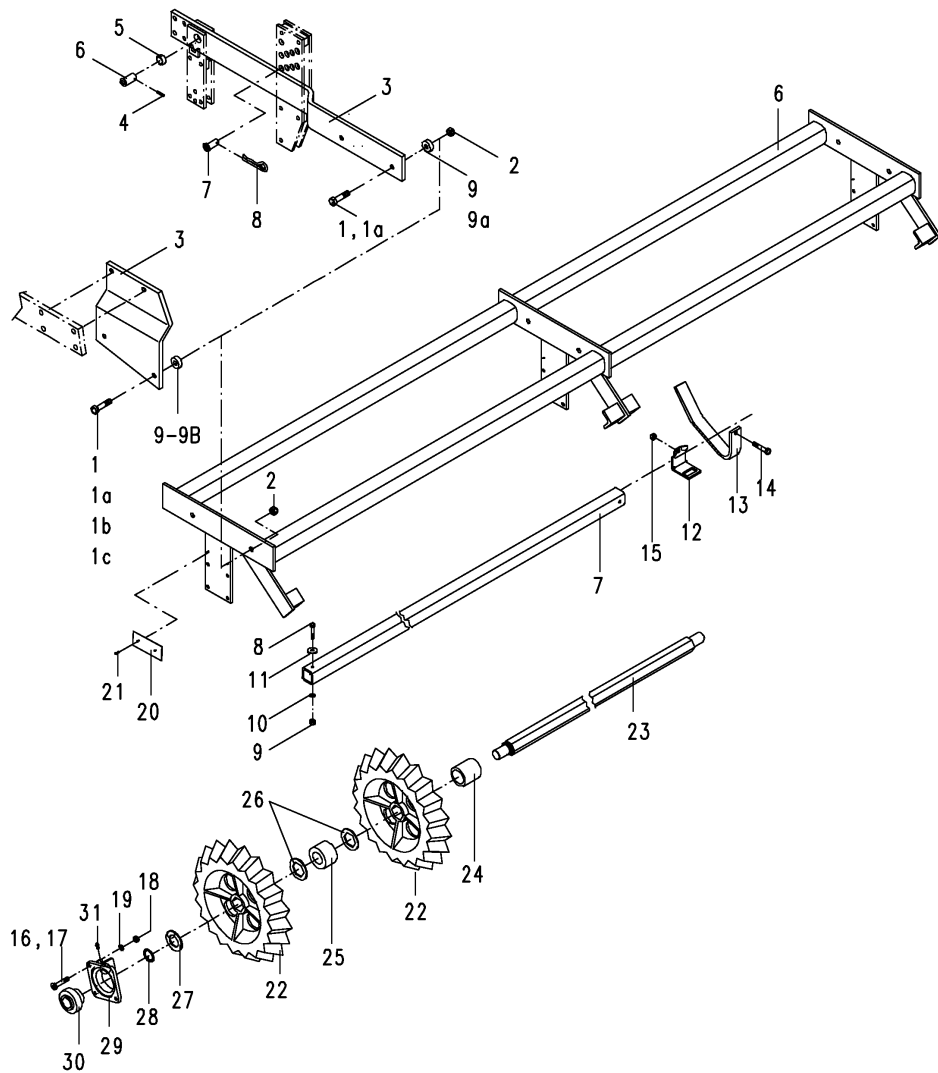

2213_C2

 Polygonwalze
 Polygon roller
 Rouleau polygone

Corvus PKE Br.5, Corvex P Br.6

Bild Ref. Fig.	Bestellnr. Part-No. Référence	Stck. Qty. Qte.	Bezeichnung	Technische Angaben Technical data Données techniques	Description	Désignation
7	6809.05.02	1	Abstreiferschiene	1,25 m	Scraper rail	Porte decrottoir
7	6809.05.03	1	Abstreiferschiene	1,00 m	Scraper rail	Porte decrottoir
7	6809.05.07	1	Abstreiferschiene	1,35m	Scraper rail	Porte decrottoir
7	6809.05.08	1	Abstreiferschiene	1,55 m	Scraper rail	Porte decrottoir
8	931D1075NA	4,6	Sechskantschraube	M10x75 DIN931-8.8 verz.	Hex. bolt	Vis 6 pans
9	934D10N	4,6	Sechskantmutter	M10 DIN934-10	Hex. nut	Ecrou 6 pans
10	127DA10A	4,6	Federring	A10 DIN127 vz.	Springwasher	Rondelle grower
11	440DR11A	4,6	Scheibe	R11 DIN440 vz.	Washer	Rondelle
12	6252.12.00		Befestigungsplatte		Plate	Plaquette
13	6809.04.06		Abstreifer	B=45 mm	Scraper	Décrottoir
14	931D1280P		Sechskantschraube	M12x80 DIN931-8.8	Hex. bolt	Vis 6 pans
15	980DV12PA		Sicherungsmutter	VM12 DIN980-8 vz.	Lock nut	Ecrou frein
16	933D1240P	8	Sechskantschraube	M12x40 DIN933-8.8	Hex. bolt	Vis 6 pans
17	931D1250P	4,8	Sechskantschraube	M12x50 DIN931-8.8	Hex. bolt	Vis 6 pans
18	934D12PA	12,1	Sechskantmutter	M12 DIN934-8 vz.	Hex. nut	Ecrou 6 pans
19	127DA12A	12,1	Federring	A12 DIN127 vz.	Springwasher	Rondelle grower
22-31	6809.61.03	1	WALZENMONTAGE	1,50 M	ROLLER	MONTAGE ROULEAUX
22-31	6809.61.04	1	WALZENMONTAGE	1,25 M	ROLLER	MONTAGE ROULEAUX
22-31	6809.61.05	1	WALZENMONTAGE	1,00 M	ROLLER	MONTAGE ROULEAUX
22-31	6809.61.07	1	WALZENMONTAGE	1,35 M	ROLLER	MONTAGE ROULEAUX
22-31	6809.61.08	1	WALZENMONTAGE	1,55 M	ROLLER	MONTAGE ROULEAUX
22	6809.01.02	8-13	Polygonring	Ø450 mm	Polygonring	Disc polygone
23	6809.55.01	1	Sechskantachse	L=1448 mm	Hexagon axle	Axe à six pans
23	6809.55.02	1	Sechskantachse	L=1208 mm	Hexagon axle	Axe à six pans
23	6809.55.03	1	Sechskantachse	L=968 mm	Hexagon axle	Axe à six pans
23	6809.55.07	1	Sechskantachse	L=1328 mm	Hexagon axle	Axe à six pans
23	6809.55.08	1	Sechskantachse	L=1568 mm	Hexagon axle	Axe à six pans
24	6809.04.04	5-10	Rohr		Pipe	Tube
25	6809.60.01	1	Ausgleichsfeder		Spring	Ressort
26	6809.61.01	3,4	Ausgleichscheibe		Shim ring	Rondelle
27	6809.61.02	2	Distanzscheibe		Spacer	Entretoise
28	471D452.5	2	Sicherungsring	45x2,5 DIN471	Circlip	Circlip
29-31	6809.23.01	2	FLANSLAGER KPL.	Ø35	BEARING CPL.	PALIER CPL.
29	8409.00.41	2	Flanschlager		Bearing	Palier
30	8020.81.02	2	Lager		Bearing	Palier
31	71412DA81	2	Schmiernippel	AM8x1 DIN71412	Grease nippel	Graisneur

2213_D

Antrieb
Drive
Entrainement

Corvus PKE Br.5, Corvex P Br.6

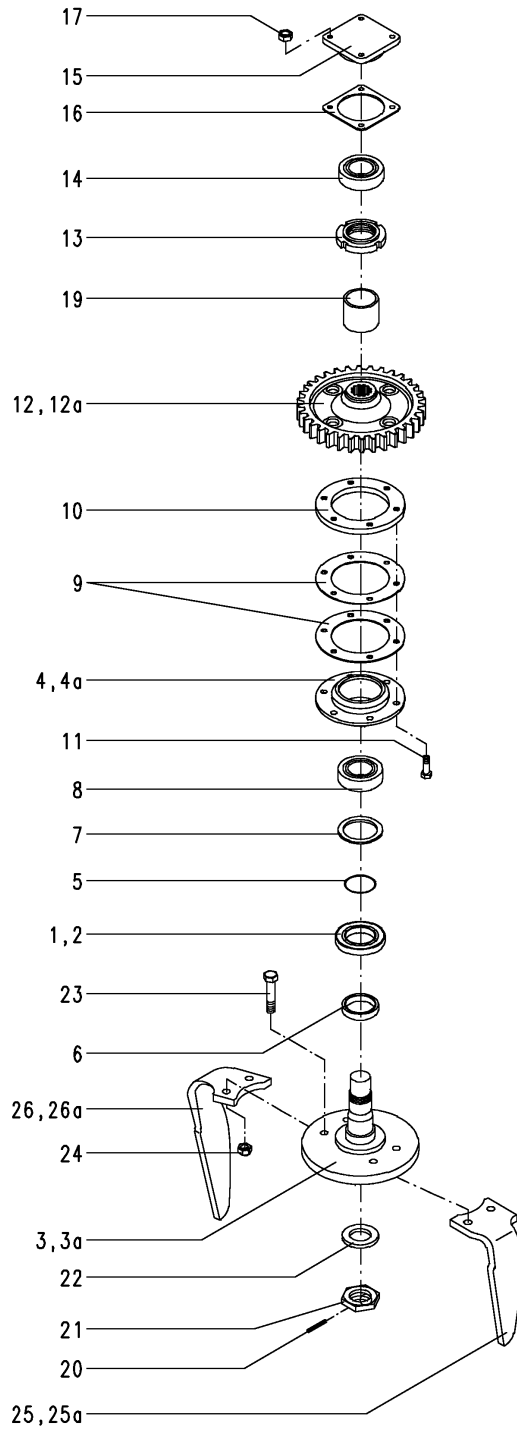

2213_D

 Antrieb
 Drive
 Entraînement

Corvus PKE Br.5, Corvex P Br.6

Bild Ref. Fig.	Bestellnr. Part-No. Référence	Stck. Qty. Qte.	Bezeichnung	Technische Angaben Technical data Données techniques	Description	Désignation
1	8433.00.13		Wellendichtring	70/100/10	Shaft sealing ring	Joint de arbre
2	8404.27.00		Gamma-Ring	RB-70X90X5,5	Gamma ring	Joint gamma
3	8413.00.17		Welle+Messerhalter, links		Shaft with kniftein holder	Arbre porte couteau
3a	8413.00.14	1	Messerhalter		Holder	Porte bêche
4	8413.00.20		Lagerflansch		Bearing flange	Bride support
4a	8413.00.21	1	Lagerflansch Mitte		Bearing flange	Bride support
5	8404.26.06		O-Ring	55x2	O-seal	Joint torique
6	8413.00.18		Laufring		Ring	Baque
7	472D1003		Sicherungsring	100x3 DIN472	Circlip	Circlip
8	625D6211		Rillenkugellager	6211 DIN625	Ball bearing	Roulement à billes
9	8413.00.23		Lagerflanschdichtung		Seal	Joint
10	8413.00.22		Bodenverstärkung		Reinforcement	Renforcement
11	8426.13.07		Verbus-Ripp-Sechskantsc hraube	M12x30-100	Verbus-Ripp bolt	Boulon hex. indesserable
12	8413.00.15		Zahnrad	Z 49	Gear	Rou dentré
12a	8413.00.11	1	Zahnrad	Z 49	Gear	Rou dentré
13	8413.00.32		Nutmutter	PM 50x1,5 SSN 546	Key nut	Ecrou à garges
14	625D62082RS		Rillenkugellager	6208 2RS DIN625	Ball bearing	Roulement à billes
15	8427.11.00		Lagerdeckel		Bearing cover	Couvercle
16	8427.12.00		Lagerdeckeldichtung		Seal	Joint
17	980DV10NA		Sicherungsmutter	VM10 DIN980-10 vz.	Lock nut	Ecrou frein
19	8437.00.08	1	Distanzhülse		Spacer	Bague entretoise
20	1481D650	1	Spannstift	6x50 DIN1481	Dowel Pin	Goupille serrage
21	937D3615P	1	Kronenmutter	M36x1,5 DIN937-8	Castellated nut	Ecrou crânelé
22	126D36		Scheibe	36 DIN126	Washer	Rondelle
23	960D161565M		Sechskantschraube	M16x1,5x65 DIN960-12.9	Hex. bolt	Vis 6 pans
24	8405.00.18		Poly-Stop-Sechskantmutt er	M16x1,5	Poly-Stop nut	Ecrou Poly-Stop
25	8404.50.01		Kreismesser, rechts	KG-30	Knife tine	Couteau
25a	8411.62.03		RABID-Kreismesser, rechts	KG-30 Z	Knife tine-RABID-	Couteau-RABID-
26	8404.50.02		Kreismesser, links	KG-30 L	Knife tine	Couteau
26a	8411.62.04		RABID-Kreismesser, links	KG-30 LZ	Knife tine-RABID-	Couteau-RABID-

2213_D1

Schnellwechselsystem
Quick-Fit tines
Kit de demontage rapide

Corvus PKE Br.5, Corvex P Br. 6

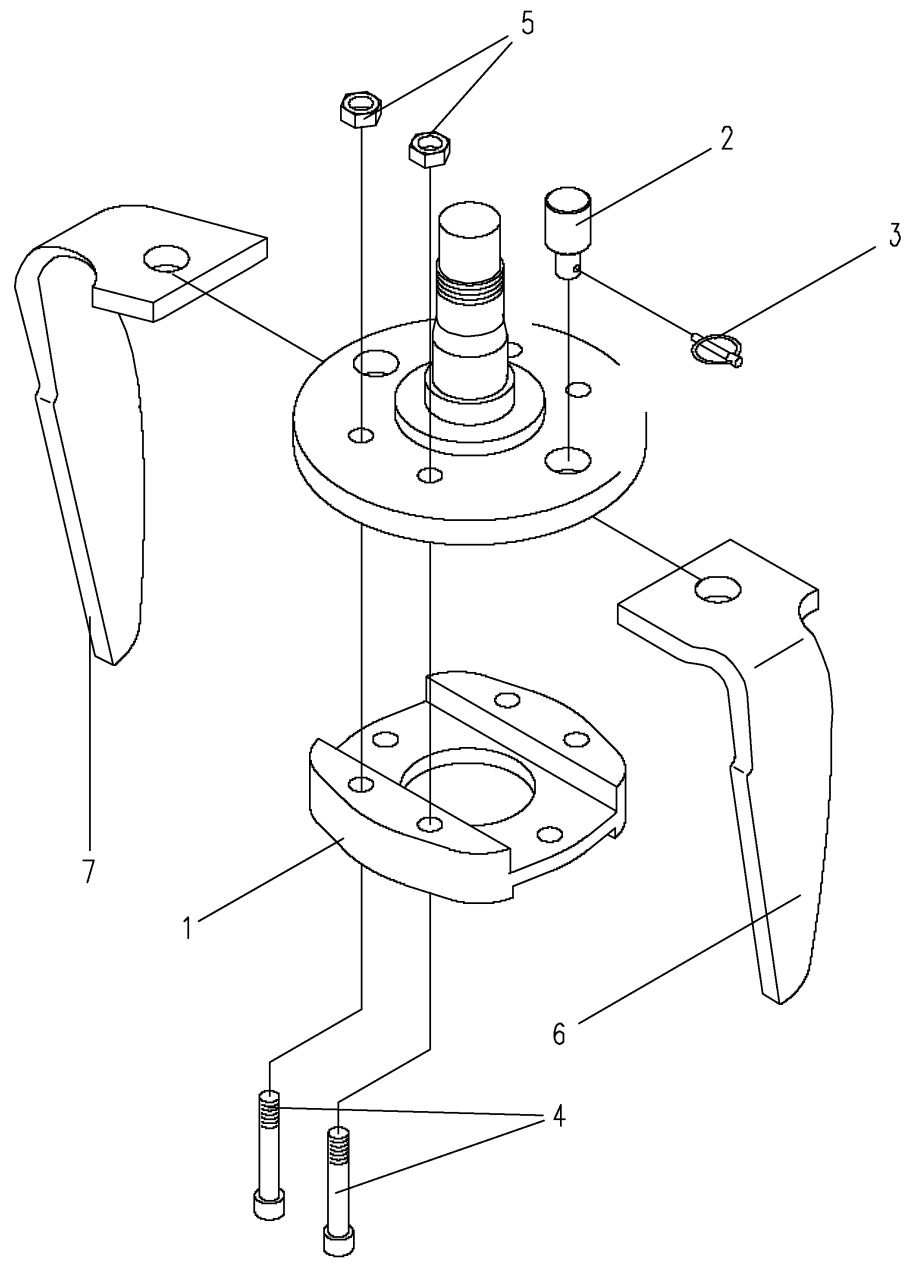

2213_D1

 Schnellwechselsystem
 Quick-Fit tines
 Kit de demontage rapide

Corvus PKE Br.5, Corvex P Br.6

Bild Ref. Fig.	Bestellnr. Part-No. Référence	Stck. Qty. Qte.	Bezeichnung	Technische Angaben Technical data Données techniques	Description	Désignation
1-5	8437.75.01	1	SCHNELLWECHSELSYS T.	Typ "Corvex"	QUICK-FIT TINES	KIT DE DEMONT.RAPIDE
1	8437.74.02	1	Grundplatte		Connecting plate	Plaque à visser
2	8437.75.02	2	Bolzen		Pin	Axe
3	8405.12.11	2	Sicherheits-Klappstecker	5x21	Linch-pin	Goupille auto.
4	912D161570M	4	Zylinderschraube	M16x1,5x70 DIN912-12.9	Spline screw	Vis cylindrique
5	8405.00.18	4	Poly-Stop-Sechskantmutter	M16x1,5	Poly-Stop nut	Ecrou Poly-Stop
6	8437.77.01	1	Kreismesser, rechts	KG-34	Knife tine	Couteau
6	8411.62.15	1	RABID-Kreismesser, rechts	KG-34 Z	Knife tine-RABID-	Couteau-RABID-
7	8437.77.02	1	Kreismesser, links	KG-34 L	Knife tine	Couteau
7	8411.62.16	1	RABID-Kreismesser, links	KG-34 LZ	Knife tine-RABID-	Couteau-RABID-

2213_E

Wechselradgetriebe
Gearbox
Boîtier de vitesse

Corvus PKE Br.5, Corvex P Br.6

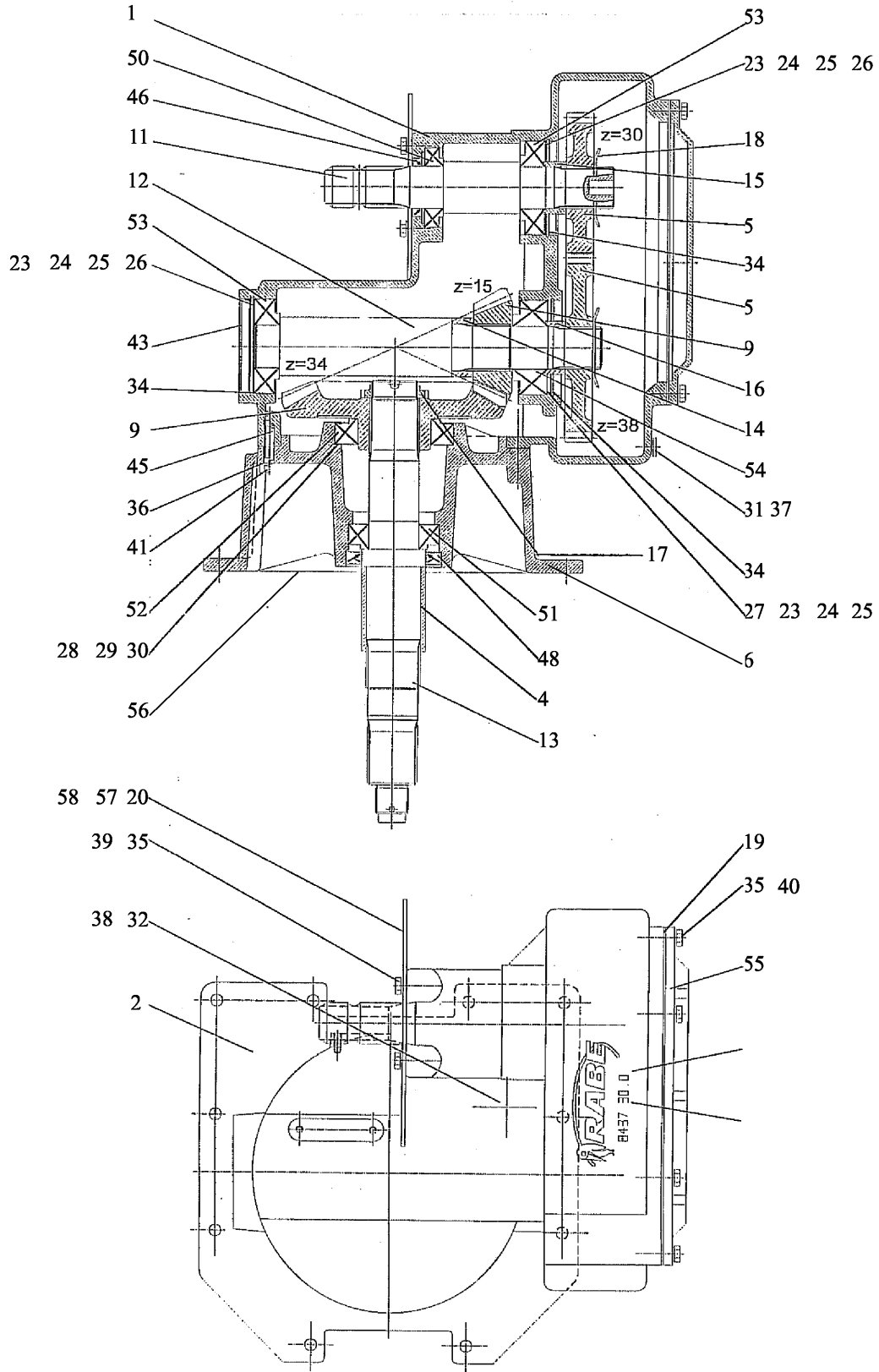

2213_E

 Wechselradgetriebe
 Gearbox
 Boîtier de vitesse

Corvus PKE Br.5, Corvex P Br.6

Bild Ref. Fig.	Bestellnr. Part-No. Référence	Stck. Qty. Qte.	Bezeichnung	Technische Angaben Technical data Données techniques	Description	Désignation
	8437.90.01	1	GETRIEBE	3,0 m+4,0 m	GEARBOX	BOITIER DE VITESSE
	8437.90.02	1	GETRIEBE	4,5 m	GEARBOX	BOITIER DE VITESSE
1	8437.70.11	1	Gehäuse		Housing	Carter
2	8437.70.12	1	Lagergehäuse		Bearing housing	Braquette
4	8437.90.11	1	Distanzbuchse		Spacer	Bague entretoise
5	8437.73.03	1	Wechselradsatz	Z 30/38	Change gear kit	Jeu de pignon interchange.
5	8437.73.01	1	Wechselradsatz	Z 25/43	Change gear kit	Jeu de pignon interchange.
5	8437.73.02	1	Wechselradsatz	Z 27/41	Change gear kit	Jeu de pignon interchange.
5	8437.73.04	1	Wechselradsatz	Z 32/36	Change gear kit	Jeu de pignon interchange.
5	8437.73.05	1	Wechselradsatz	Z 33/35	Change gear kit	Jeu de pignon interchange.
6	8437.90.13	1	Gehäusesockel		Base	Base
9	8437.70.35	1	Kegeltrieb kpl.	Z 15/34, 3,0 m+4,0 m	Bevel gear set	Paire de pignons coniques
9	8437.70.36	1	Kegeltrieb kpl.	Z 15/34, 2,5 m+4,5 m	Bevel gear set	Paire de pignons coniques
11	8437.70.17	1	Antriebswelle		Input shaft	Arbre d'entree
12	8437.70.18	1	Ritzelwelle		Pinion shaft	Arbre intermediaire
13	8437.90.10	1	Getriebewelle		Shaft	Arbre
14	8437.70.23	1	Buchse		Bush	Douille
15	8437.70.24	1	Buchse		Bush	Douille
16	8437.70.25	1	Buchse		Bush	Douille
17	8437.70.20	1	Nutmutter	M50x1,5	Key nut	Ecrou à garges
18	8437.70.21	2	Feder		Spring	Ressort
19	8437.70.22	1	Deckeldichtung		Packing	Joint de couvercle
20	8437.70.26	1	Blech		Plate	Tôle
23	988D851001	2	Paßscheibe	85x100x1 DIN988	Gauge washer	Cale d'ajustage
24	988D851000.1	6	Paßscheibe	85x100x0,1 DIN988	Gauge washer	Cale d'ajustage
25	988D851000.2	6	Paßscheibe	85x100x0,2 DIN988	Gauge washer	Cale d'ajustage
26	988D851000.3	4	Paßscheibe	85x100x0,3 DIN988	Gauge washer	Cale d'ajustage
27	988DS85100	1	Stützscheibe	S 85x100 DIN988	Supporting washer	Rondelle pour bague
28	988D1101300.1	2	Paßscheibe	110x130x0,1 DIN988	Gauge washer	Cale d'ajustage
29	988D1101300.2	2	Paßscheibe	110x130x0,2 DIN988	Gauge washer	Cale d'ajustage
30	988D1101300.3	2	Paßscheibe	110x130x0,3 DIN988	Gauge washer	Cale d'ajustage
31	7603DA162215 CU	1	Dichtring	A 16x22x1,5 DIN7603-CU	Seal ring	Joint
32	7603DA26322 CU	1	Dichtring	A 26x32x2 DIN7603-CU	Seal ring	Joint
34	472D1003	3	Sicherungsring	100x3 DIN472	Circlip	Circlip
35	127DA8A	13	Federring	A8 DIN127 vz.	Springwasher	Rondelle grower

2213_E

Wechselradgetriebe
Gearbox
Boîtier de vitesse

Corvus PKE Br.5, Corvex P Br.6

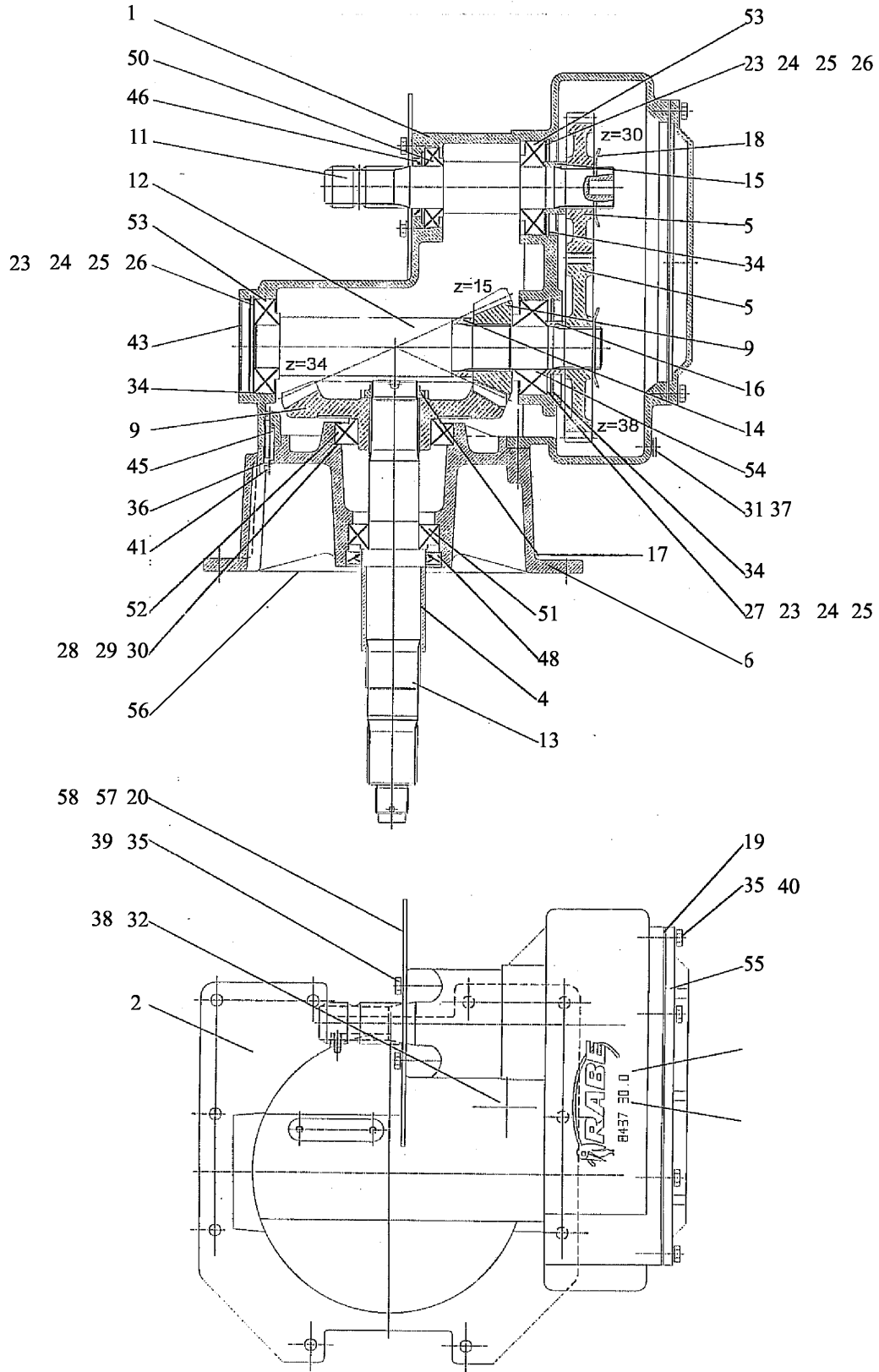

2213_E

 Wechselradgetriebe
 Gearbox
 Boîtier de vitesse

Corvus PKE Br.5, Corvex P Br.6

Bild Ref. Fig.	Bestellnr. Part-No. Référence	Stck. Qty. Qte.	Bezeichnung	Technische Angaben Technical data Données techniques	Description	Désignation
36	WAL596279	8	Scheibe	A 12 Form M verzinkt	Washer	Rondelle
37	908D1615V	1	Verschlußschraube	M16x1,5 DIN908-5.8	Hexagon head plug	Bouchon fileté
38	908D2615V	1	Verschlußschraube	M26x1,5 DIN908-5.8	Hexagon head plug	Bouchon fileté
39	933D816P	2	Sechskantschraube	M8x16 DIN933-8.8	Hex. bolt	Vis 6 pans
40	933D825P	11	Sechskantschraube	M8x25 DIN933-8.8	Hex. bolt	Vis 6 pans
41	933D1240N	8	Sechskantschraube	M12x40 DIN933-10.9	Hex. bolt	Vis 6 pans
43	WAL593767	1	Verschlußkappe		End lid	Couvercle de fermé
45	6325D10M636	2	Zylinderstift	10m6 x36 DIN6325	Cylindrical dovel	Goupille fendue
46	3760D456210B A	1	Wellendichtring	45x62x10 BA DIN3760	Shaft sealing ring	Joint de arbre
48	3760D7010513 B2	1	Wellendichtring	70x105x13 B2 DIN3760	Shaft sealing ring	Joint de arbre
50	720D30209	1	Kegelrollenlager	30209 DIN720	Taper roller bearing	Roulement à rouleaux
51	720D30211	1	Kegelrollenlager	30211 DIN720	Taper roller bearing	Roulement à rouleaux
52	720D30215	1	Kegelrollenlager	30215 DIN720	Taper roller bearing	Roulement à rouleaux
53	720D30309	2	Kegelrollenlager	30309 DIN720	Taper roller bearing	Roulement à rouleaux
54	720D32309	1	Kegelrollenlager	32309 DIN720	Taper roller bearing	Roulement à rouleaux
55	8437.70.13	1	Deckel		Lid	Couvercle
56	8437.00.30	1	Getriebedichtung		Gasket	Joint de boîte de vitesse
57	8437.72.99	1	Schutz kpl.		Cover cpl.	Protection cpl.
58	933D820PA	2	Sechskantschraube	M8x20 DIN933-8.8 vz.	Hex. bolt	Vis 6 pans
	GETRIEBEOEL /5	4,5	Getriebeöl	Hypoid GL 5 SAE 90	Gear oil	Huile

2213_E1

Wechselradgetr. mit Durchtr.
Gearbox with PTO through drive
Boîtier de vitesse avec prise de
force arr.

Corvus PKE Br.5, Corvex P Br.6

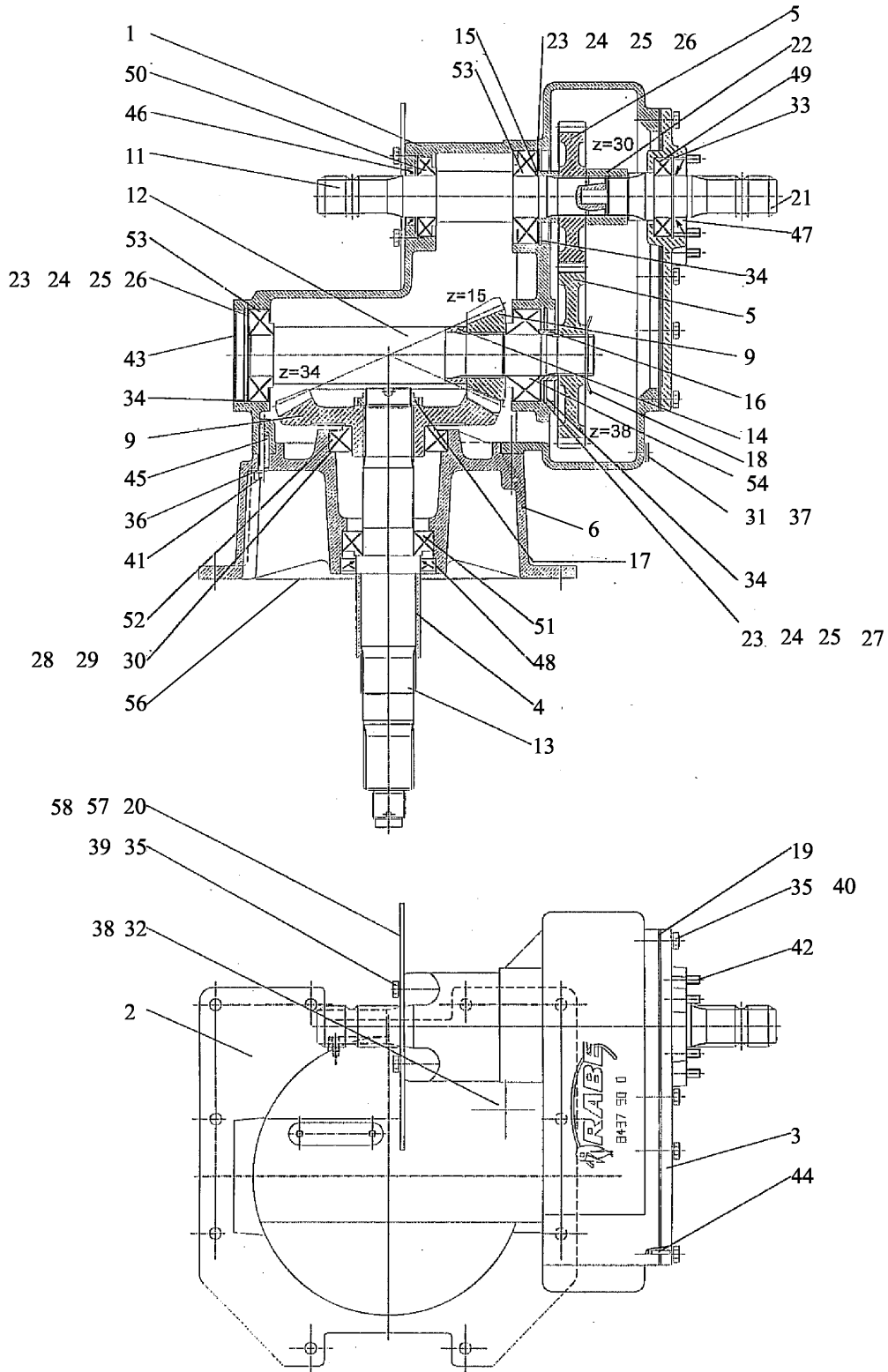

2213_E1

 Wechselradgetr. mit Durchtr.
 Gearbox with PTO through drive
 Boîtier de vitesse avec prise de
 force arr.

Corvus PKE Br.5, Corvex P Br.6

Bild Ref. Fig.	Bestellnr. Part-No. Référence	Stck. Qty. Qte.	Bezeichnung	Technische Angaben Technical data Données techniques	Description	Désignation
	8437.90.03	1	GETRIEBE M. DURCHTR.	1 3/4", 3,0 m+4,0 m	GEARBOX+THROU.D RIV.	BOITIER+PRISE DE FORCE A
	8437.90.04	1	GETRIEBE M. DURCHTR.	1 3/4", 4,5 m	GEARBOX+THROU.D RIV.	BOITIER+PRISE DE FORCE A
	8437.90.05	1	GETRIEBE M. DURCHTR.	1 3/8", 3,0 m+4,0 m	GEARBOX+THROU.D RIV.	BOITIER+PRISE DE FORCE A
	8437.90.06	1	GETRIEBE M. DURCHTR.	1 3/8", 4,5 m	GEARBOX+THROU.D RIV.	BOITIER+PRISE DE FORCE A
	8437.91.50	1	DURCHTR.-NACHRÜSTUNG	1 3/4"	PTO THROUGH DRIVE	PRISE DE FORCE ARR.
	8437.91.51	1	DURCHTR.-NACHRÜSTUNG	1 3/8"	PTO THROUGH DRIVE	PRISE DE FORCE ARR.
1	8437.70.11	1	Gehäuse		Housing	Carter
2	8437.70.12	1	Lagergehäuse		Bearing housing	Braquette
3	8437.70.42	1	Deckel f. Durchtrieb		Cover	Couvercle
4	8437.90.11	1	Distanzbuchse		Spacer	Bague entretoise
5	8437.73.03	1	Wechselradsatz	Z 30/38	Change gear kit	Jeu de pignon interchange.
5	8437.73.01	1	Wechselradsatz	Z 25/43	Change gear kit	Jeu de pignon interchange.
5	8437.73.02	1	Wechselradsatz	Z 27/41	Change gear kit	Jeu de pignon interchange.
5	8437.73.04	1	Wechselradsatz	Z 32/36	Change gear kit	Jeu de pignon interchange.
5	8437.73.05	1	Wechselradsatz	Z 33/35	Change gear kit	Jeu de pignon interchange.
6	8437.90.13	1	Gehäusesockel		Base	Base
9	8437.70.35	1	Kegeltrieb kpl.	Z 15/34, 3,0 m+4,0 m	Bevel gear set	Paire de pignons coniques
9	8437.70.36	1	Kegeltrieb kpl.	Z 15/34, 2,5 m+4,5 m	Bevel gear set	Paire de pignons coniques
11	8437.70.17	1	Antriebswelle		Input shaft	Arbre d'entree
12	8437.70.18	1	Ritzelwelle		Pinion shaft	Arbre intermediaire
13	8437.90.10	1	Getriebewelle		Shaft	Arbre
14	8437.70.23	1	Buchse		Bush	Douille
15	8437.70.24	1	Buchse		Bush	Douille
16	8437.70.25	1	Buchse		Bush	Douille
17	8437.70.20	1	Nutmutter	M50x1,5	Key nut	Ecrou à garges
18	8437.70.21	2	Feder		Spring	Ressort
19	8437.70.22	1	Deckeldichtung		Packing	Joint de couvercle
20	8437.70.26	1	Blech		Plate	Tôle
21	8437.70.40	1	Durchtriebswelle	1 3/8"	Input shaft	Arbre d'entree
21	8437.70.41	1	Durchtriebswelle	1 3/4"	Input shaft	Arbre d'entree
22	8437.70.44	1	Buchse		Bush	Douille
23	988D851001	2	Paßscheibe	85x100x1 DIN988	Gauge washer	Cale d'ajustage
24	988D851000.1	6	Paßscheibe	85x100x0,1 DIN988	Gauge washer	Cale d'ajustage
25	988D851000.2	6	Paßscheibe	85x100x0,2 DIN988	Gauge washer	Cale d'ajustage
26	988D851000.3	4	Paßscheibe	85x100x0,3 DIN988	Gauge washer	Cale d'ajustage

2213_E1

Wechselradgetr. mit Durchtr.
Gearbox with PTO through drive
Boîtier de vitesse avec prise de
force arr.

Corvus PKE Br.5, Corvex P Br.6

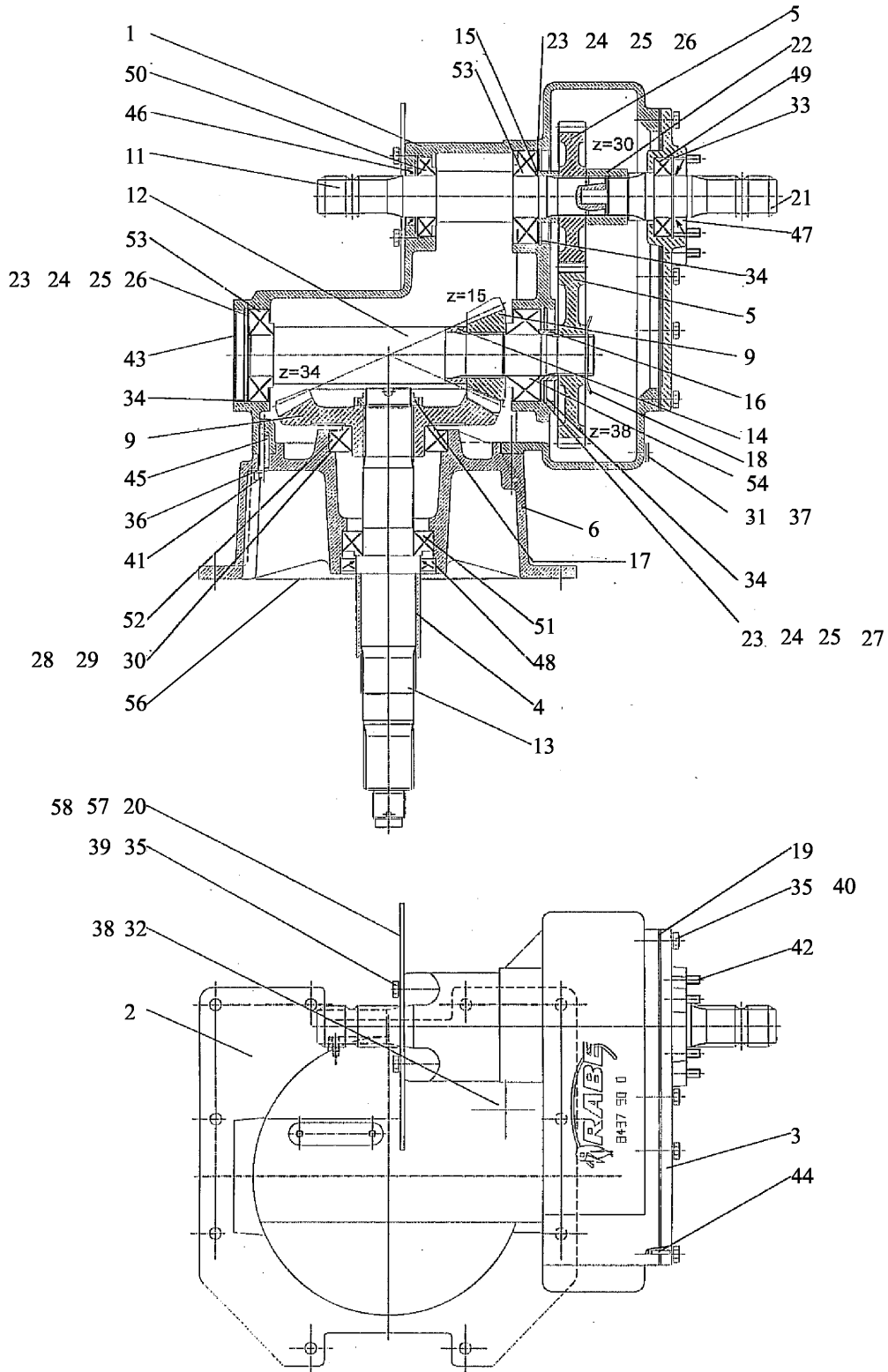

2213_E1

 Wechselradgetr. mit Durchtr.
 Gearbox with PTO through drive
 Boîtier de vitesse avec prise de
 force arr.

Corvus PKE Br.5, Corvex P Br.6

Bild Ref. Fig.	Bestellnr. Part-No. Référence	Stck. Qty. Qte.	Bezeichnung	Technische Angaben Technical data Données techniques	Description	Désignation
27	988DS85100	1	Stützscheibe	S 85x100 DIN988	Supporting washer	Rondelle pour bague
28	988D1101300.1	2	Paßscheibe	110x130x0,1 DIN988	Gauge washer	Cale d'ajustage
29	988D1101300.2	2	Paßscheibe	110x130x0,2 DIN988	Gauge washer	Cale d'ajustage
30	988D1101300.3	2	Paßscheibe	110x130x0,3 DIN988	Gauge washer	Cale d'ajustage
31	7603DA162215 CU	1	Dichtring	A 16x22x1,5 DIN7603-CU	Seal ring	Joint
32	7603DA26322 CU	1	Dichtring	A 26x32x2 DIN7603-CU	Seal ring	Joint
33	472D853	1	Sicherungsring	85x3 DIN472	Circlip	Circlip
34	472D1003	3	Sicherungsring	100x3 DIN472	Circlip	Circlip
35	127DA8A	13	Federring	A8 DIN127 vz.	Springwasher	Rondelle grower
36	WAL596279	8	Scheibe	A 12 Form M verzinkt	Washer	Rondelle
37	908D1615V	1	Verschlußschraube	M16x1,5 DIN908-5.8	Hexagon head plug	Bouchon fileté
38	908D2615V	1	Verschlußschraube	M26x1,5 DIN908-5.8	Hexagon head plug	Bouchon fileté
39	933D816P	2	Sechskantschraube	M8x16 DIN933-8.8	Hex. bolt	Vis 6 pans
40	933D825P	11	Sechskantschraube	M8x25 DIN933-8.8	Hex. bolt	Vis 6 pans
41	933D1240N	8	Sechskantschraube	M12x40 DIN933-10.9	Hex. bolt	Vis 6 pans
42	913D1030N	4	Gewindestift	M10x30 DIN913-10.9	Threaded pin	Vis sans fete
43	WAL593767	1	Verschlußkappe		End lid	Couvercle de fermé
44	6325D8M628	2	Zylinderstift	8m6 x28 DIN6325	Cylindrical dovel	Goupille fendue
45	6325D10M636	2	Zylinderstift	10m6 x36 DIN6325	Cylindrical dovel	Goupille fendue
46	3760D456210B A	1	Wellendichtring	45x62x10 BA DIN3760	Shaft sealing ring	Joint de arbre
47	3760D458513B 2	1	Wellendichtring	45x85x13 B2 DIN3760	Shaft sealing ring	Joint de arbre
48	3760D7010513 B2	1	Wellendichtring	70x105x13 B2 DIN3760	Shaft sealing ring	Joint de arbre
49	625D6209	1	Rillenkugellager	6209 DIN625	Ball bearing	Roulement à billes
50	720D30209	1	Kegelrollenlager	30209 DIN720	Taper roller bearing	Roulement à rouleaux
51	720D30211	1	Kegelrollenlager	30211 DIN720	Taper roller bearing	Roulement à rouleaux
52	720D30215	1	Kegelrollenlager	30215 DIN720	Taper roller bearing	Roulement à rouleaux
53	720D30309	2	Kegelrollenlager	30309 DIN720	Taper roller bearing	Roulement à rouleaux
54	720D32309	1	Kegelrollenlager	32309 DIN720	Taper roller bearing	Roulement à rouleaux
55	8437.70.13	1	Deckel		Lid	Couvercle
56	8437.00.30	1	Getriebedichtung		Gasket	Joint de boîte de vitesse
57	8437.72.99	1	Schutz kpl.		Cover cpl.	Protection cpl.
58	933D820PA	2	Sechskantschraube	M8x20 DIN933-8.8 vz.	Hex. bolt	Vis 6 pans
	GETRIEBEOEL /5	4,5	Getriebeöl	Hypoid GL 5 SAE 90	Gear oil	Huile

2213_E2

Schutz f. Durchtr.
Cover
Protection

Corvus PKE Br.5, Corvex P Br.6

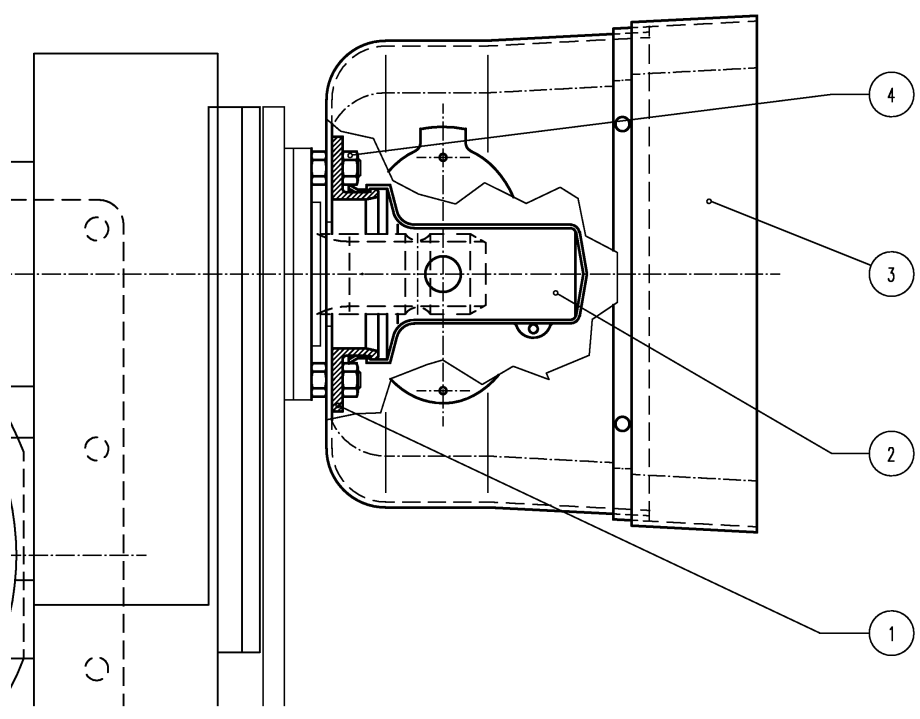

2213_E2

 Schutz f. Durchtr.
 Cover
 Protection

Corvus PKE Br.5, Corvex P Br.6

Bild Ref. Fig.	Bestellnr. Part-No. Référence	Stck. Qty. Qte.	Bezeichnung	Technische Angaben Technical data Données techniques	Description	Désignation
1-4	8437.10.06	1	SCHUTZ F. DURCHTR.		COVER CPL.	PROTECTION CPL.
1	8437.10.08	1	Adapterring		Ring	Bague
2	8435.03.09	1	Zapfwelenschutz		PTO shield	Dispositif de protection
3	8437.10.07	1	Schutztopf		Safety shield	Bol protecteur
4	934D10PA	4	Sechskantmutter	M10 DIN934-8 vz.	Hex. nut	Ecrou 6 pans

2213_F

Englandschutz
Protection -GB-
Protection -GB-

Corvus PKE Br.5, Corvex P Br.6

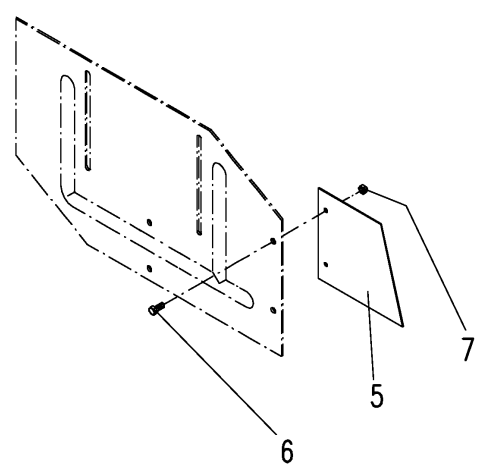
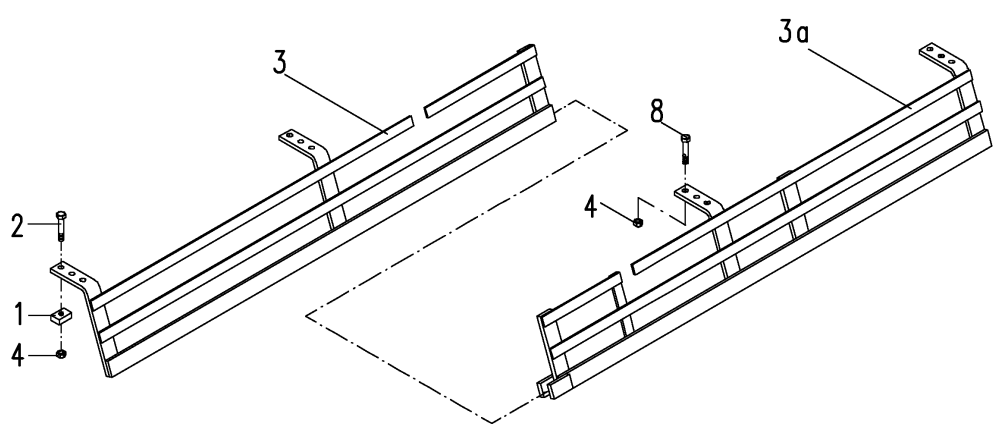

2213_F

 Englandschutz
 Protection -GB-
 Protection -GB-

Corvus PKE Br.5, Corvex P Br.6

Bild Ref. Fig.	Bestellnr. Part-No. Référence	Stck. Qty. Qte.	Bezeichnung	Technische Angaben Technical data Données techniques	Description	Désignation
1	8413.00.37	2	Unterlage		Shim	Cale
2	931D1255N	4	Sechskantschraube	M12 x 55 DIN931-10.9	Hex. bolt	Vis 6 pans
3	8412.57.04	1	Schutzgitter, hinten links	3,0 m	Rear protection l.h.	Protection arrière gauche
3	8412.57.06	1	Schutzgitter, hinten links	4,0 m	Rear protection l.h.	Protection arrière gauche
3	8412.57.36	1	Schutzgitter, hinten links	4,5 m	Rear protection l.h.	Protection arrière gauche
3a	8412.57.03	1	Schutzgitter, hinten rechts	3,0 m	Rear protection r.h.	Protection arrière droit
3a	8412.57.05	1	Schutzgitter, hinten rechts	4,0 m	Rear protection r.h.	Protection arrière droit
3a	8412.57.35	1	Schutzgitter, hinten rechts	4,5 m	Rear protection r.h.	Protection arrière droit
4	980DV12NA	4	Sicherungsmutter	VM12 DIN980-10 vz.	Lock nut	Ecrou frein
5	8412.59.01	2	Seitenschutz		Lock plate	Tôle de sécurité
6	933D1020P	4	Sechskantschraube	M10x20 DIN933-8.8	Hex. bolt	Vis 6 pans
7	980DV10PA	4	Sicherungsmutter	VM10 DIN980-8 vz.	Lock nut	Ecrou frein
8	931D1240N	4	Sechskantschraube	M12x40 DIN931-10.9	Hex. bolt	Vis 6 pans

2213_G

Prallblech
Clod bar
Chicane

Corvus PKE Br.5, Corvex P Br.6

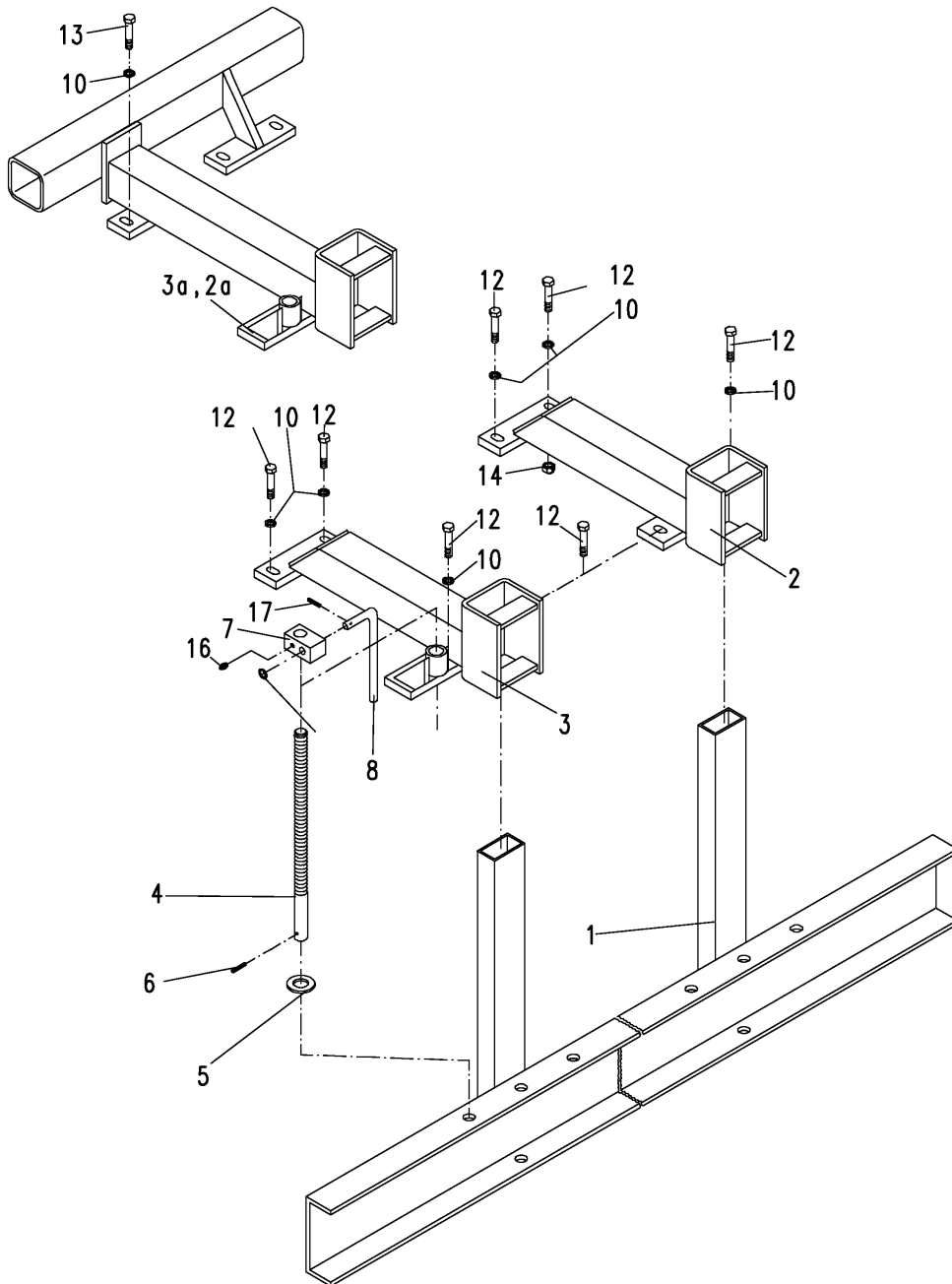

2213_G

 Prallblech
 Clod bar
 Chicane

Corvus PKE Br.5, Corvex P Br.6

Bild Ref. Fig.	Bestellnr. Part-No. Référence	Stck. Qty. Qte.	Bezeichnung	Technische Angaben Technical data Données techniques	Description	Désignation
1	8437.84.02	1	Prallschiene	(Corvus/Corvex) MKE/M 2,5m	Clod bar	Chicane
1	8437.84.03	1	Prallschiene	2,5m	Clod bar	Chicane
1	8437.84.04	1	Prallschiene	3,0m	Clod bar	Chicane
1	8437.84.05	1	Prallschiene	3,5m	Clod bar	Chicane
1	8437.84.06	1	Prallschiene	4,0m	Clod bar	Chicane
1	8437.84.07	1	Prallschiene	4,5m	Clod bar	Chicane
2	8413.52.01	1	Träger rechts		Bracket	Support
3	8413.52.02	1	Träger links		Bracket	Support
2a	8426.40.02	1	Kombiträger, rechts	(Corvus) 2,5m	Combi bracket r.h.	Support combi.droit
3a	8426.40.01	1	Kombiträger, links	(Corvus) 2,5m	Combi bracket l.h.	Support combi.gauche
4	8437.83.02	2	Spindel, verzinkt		Spindle	Manivelle
5	126D26A	2	Scheibe	26 DIN126 vz.	Washer	Rondelle
6	1481D860A	2	Spannstift	8x60 DIN1481 vz.	Dowel Pin	Goupille serrage
7	8413.54.02	2	Spindelverstellung		Depth adjust.	Goupille élastique
8	8409.00.34	2	Drehgriff		Crank	Broche
9	126D14	2	Scheibe	14 DIN126	Washer	Rondelle
10	7349D13A	8	Scheibe	13 DIN7349 vz.	Washer	Rondelle
11	8413.00.37	2	Unterlage		Shim	Cale
12	931D1245M	8,10	Sechskantschraube	M12x45 DIN931-12.9	Hex. bolt	Vis 6 pans
13	931D1255N	2	Sechskantschraube	M12 x 55 DIN931-10.9	Hex. bolt	Vis 6 pans
14	980DV12NA	8,12	Sicherungsmutter	VM12 DIN980-10 vz.	Lock nut	Ecrou frein
16	71412DA81	2	Schmiernippel	AM8x1 DIN71412	Grease nipple	Graisser
17	1481D530A	2	Spannstift	5x30 DIN1481 vz.	Dowel Pin	Goupille serrage

2213_H

Träger für Radspurlockerer
Bracket for eradicator
Support pour effaceur

Corvus PKE Br.5, Corvex P Br.6

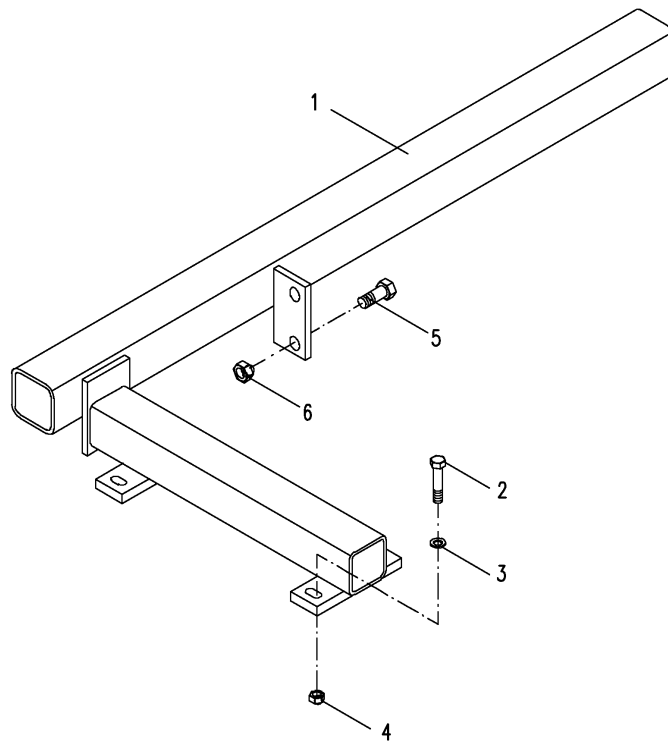

2213_H

 Träger für Radspurlockerer
 Bracket for eradicator
 Support pour effaceur

Corvus PKE Br.5, Corvex P Br.6

Bild Ref. Fig.	Bestellnr. Part-No. Référence	Stck. Qty. Qte.	Bezeichnung	Technische Angaben Technical data Données techniques	Description	Désignation
1	8426.40.01	1	Kombiträger, links	(Corvus) 2,5m	Combi bracket l.h.	Support combi.gauche
1	8426.40.02	1	Kombiträger, rechts	(Corvus) 2,5m	Combi bracket r.h.	Support combi.droit
1	8426.57.01	1	Kombiträger, links	Corvus PKE 2,5m Br.3	Combi bracket l.h.	Support combi.gauche
1	8426.57.02	1	Kombiträger, rechts	Corvus PKE 2,5m Br.3	Combi bracket r.h.	Support combi.droit
1	8426.37.09	1	Träger	(Corvus) 3,0m	Bracket	Support
1	8426.37.10	1	Träger	Corvus PKE	Bracket	Support
1	8426.39.01	1	Träger links	Br.3+CKE=3,0m (Corvus) 4,0m+ 4,5m	Bracket	Support
1	8426.39.02	1	Träger rechts	(Corvus) 4,0m+ 4,5m	Bracket	Support
1	8426.39.04	1	Träger, links	CorvusPKE Br.3+CKE=4+4,5m	Bracket l.h.	Support gauche
1	8426.39.05	1	Träger, rechts	CorvusPKE Br.3+CKE=4+4,5m	Bracket r.h.	Support droit
2	931D1245N		Sechskantschraube	M12x45 DIN931-10.9	Hex. bolt	Vis 6 pans
2	931D1255N		Sechskantschraube	M12 x 55 DIN931-10.9	Hex. bolt	Vis 6 pans
3	7349D13A		Scheibe	13 DIN7349 vz.	Washer	Rondelle
4	980DV12NA		Sicherungsmutter	VM12 DIN980-10 vz.	Lock nut	Ecrou frein
5	933D1640P		Sechskantschraube	M16x40 DIN933-8.8	Hex. bolt	Vis 6 pans
6	980DV16P		Sicherungsmutter	VM16 DIN980-8	Lock nut	Ecrou frein

2213_J

Radspurlockerer
Eradicator
Effaceur de trace

Corvus PKE Br.5, Corvex P Br.6

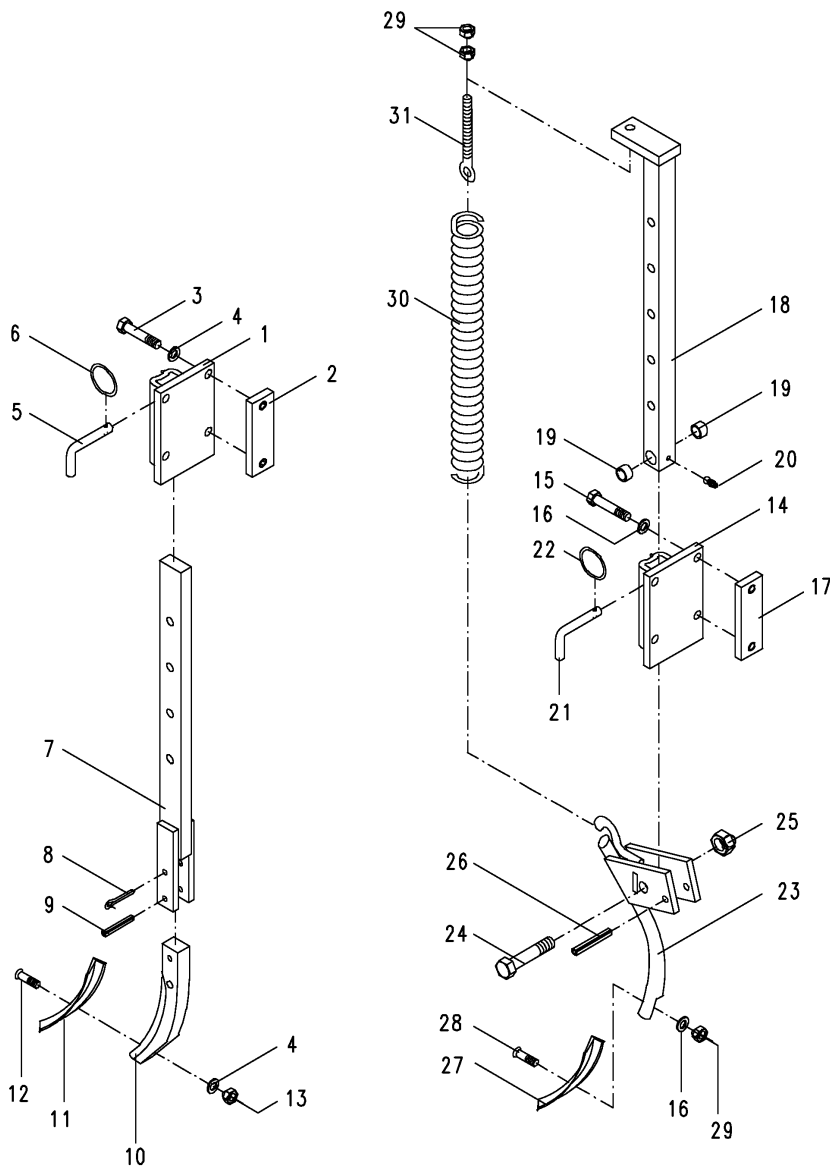

2213_J

 Radspurlockerer
 Eradicator
 Effaceur de trace

Corvus PKE Br.5, Corvex P Br.6

Bild Ref. Fig.	Bestellnr. Part-No. Référence	Stck. Qty. Qte.	Bezeichnung	Technische Angaben Technical data Données techniques	Description	Désignation
1	6241.39.00	1	Halter		Bracket	Support
2	6241.94.02	2	Gewindelasche		Latch	Plat
3	931D12110P	4	Sechskantschraube	M12x110 DIN931-8.8	Hex. bolt	Vis 6 pans
4	127DA12A	5	Federring	A12 DIN127 vz.	Springwasher	Rondelle grower
5	6241.29.02	1	Steckstock	TB-12x50	Pin	Axe
6	6608.12.07	1	Sicherungsring	3A D2076C vz.	Circlip	Circlip
7	6241.31.00	1	Stiel		Stalk	Tige
8	94D850	1	Splint	8x50 DIN94	Splint pin	Goupille fendue
9	1481D1045	1	Spannstift	10x45 DIN1481	Dowel Pin	Goupille serrage
9	1481D645	1	Spannstift	6x45 DIN1481	Dowel Pin	Goupille serrage
10	8007.24.04	1	Znkenvorderteil		Tine	Support de soc
11	8007.30.01	1	Schar	GG-5	Share	Soc
12	8007.30.02	1	Scharschraube	SSS-12x40	Bolt	Vis
13	934D12PA	1	Sechskantmutter	M12 DIN934-8 vz.	Hex. nut	Ecrou 6 pans
14	6241.95.00	1	Tasche		Clamp plate	Console
15	931D12110P	4	Sechskantschraube	M12x110 DIN931-8.8	Hex. bolt	Vis 6 pans
16	127DA12A	5	Federring	A12 DIN127 vz.	Springwasher	Rondelle grower
17	6241.94.02	2	Gewindelasche		Latch	Plat
18	6241.96.00	1	Stiel		Stalk	Tige
19	1498D162012	2	Buchse	EG 16/20x12 DIN1498	Bush	Douille
20	4716.43.00	1	Schmiernippel	H2 8x1 KX-2	Grease nippel	Graisseur
21	6241.29.02	1	Steckstock	TB-12x50	Pin	Axe
22	6608.12.07	1	Sicherungsring	3A D2076C vz.	Circlip	Circlip
23	6241.97.00	1	Znken		Tine	Dent
24	960D161565P	1	Sechskantschraube	M16x1,5x65 DIN960-8.8	Hex. bolt	Vis 6 pans
25	980DV1615P	1	Sicherungsmutter	VM16x1,5 DIN980- 8	Lock nut	Ecrou frein
26	1481D1050	1	Spannstift	10x50 DIN1481	Dowel Pin	Goupille serrage
27	8007.30.01	1	Schar	GG-5	Share	Soc
28	8007.30.02	1	Scharschraube	SSS-12x40	Bolt	Vis
29	934D12PA	3	Sechskantmutter	M12 DIN934-8 vz.	Hex. nut	Ecrou 6 pans
30	6241.94.01	1	Zugfeder	CF-287	Tension spring	Ressort
31	6241.94.04	1	Augenschraube	OS-12x90	Eyebolt	Vis à oeil
32	BL10-70X150	2	Blech		Plate	Tôle

2213_K

Leitblech
Deflector
Deflecteur

Corvus PKE Br.5, Corvex P Br.6

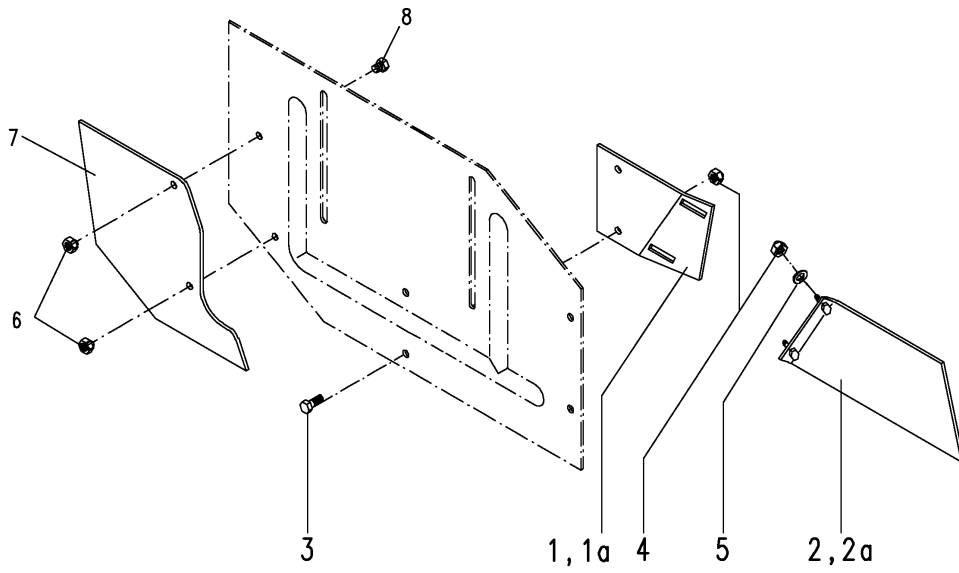

2213_K

 Leitblech
 Deflector
 Deflecteur

Corvus PKE Br.5, Corvex P Br.6

Bild Ref. Fig.	Bestellnr. Part-No. Référence	Stck. Qty. Qte.	Bezeichnung	Technische Angaben Technical data Données techniques	Description	Désignation
1	8413.55.01	1	Leitblech rechts		Deflector r.h.	Deflecteur droit
1a	8413.55.02	1	Leitblech links		Deflector l.h.	Deflecteur gauche
2	8413.56.03	1	Leitblech hinten rechts		Rear deflector r.h.	Deflecteur arrière droit
2a	8413.56.04	1	Leitblech hinten links		Rear deflector l.h.	Deflecteur arrière gauche
3	933D1025N	4	Sechskantschraube	M10x25 DIN933-10.9	Hex. bolt	Vis 6 pans
4	980DV10NA	8	Sicherungsmutter	VM10 DIN980-10 vz.	Lock nut	Ecrou frein
5	440DR11A	4	Scheibe	R11 DIN440 vz.	Washer	Rondelle
6	980DV10PA	4	Sicherungsmutter	VM10 DIN980-8 vz.	Lock nut	Ecrou frein
7	8437.71.10	2	Seitenschutz		Lock plate	Tôle de sécurité
8	933D1025P	4	Sechskantschraube	M10x25 DIN933- 8.8	Hex. bolt	Vis 6 pans

2213_L

Dreipunktgestänge mechan.
Rear hitch mechan.
Attelage 3-points mechan.

Corvus PKE Br.5, Corvex P Br.6

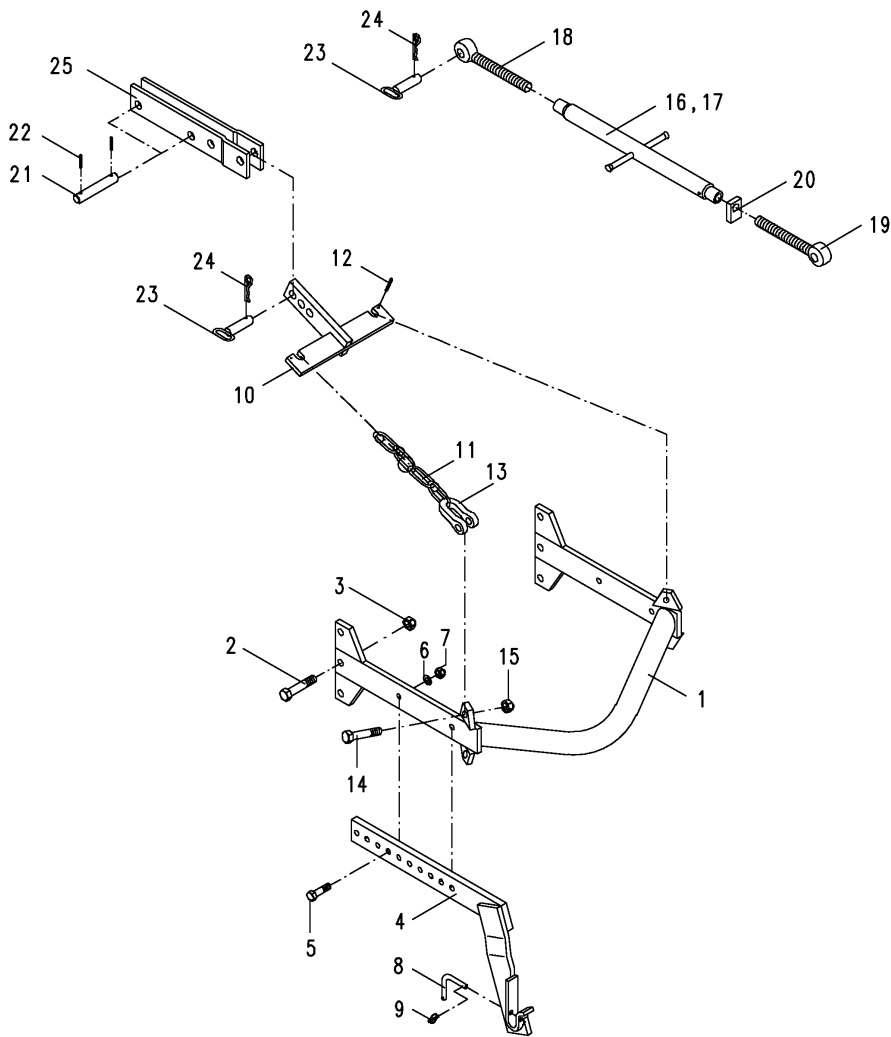

2213_L

 Dreipunktgestänge mechan.
 Rear hitch mechan.
 Attelage 3-points mechan.

Corvus PKE Br.5, Corvex P Br.6

Bild Ref. Fig.	Bestellnr. Part-No. Référence	Stck. Qty. Qte.	Bezeichnung	Technische Angaben Technical data Données techniques	Description	Désignation
1	8438.04.01	1	Grundrahmen		Frame	Bâti de base
2	931D2080P	2	Sechskantschraube	M20x80 DIN931-8.8	Hex. bolt	Vis 6 pans
3	980DV20P	2	Sicherungsmutter	VM20 DIN980-8	Lock nut	Ecrou frein
4	8405.25.01	1	Anbauarm, rechts	Kat.2	Arm r.h.	Bras droit
4	8405.25.02	1	Anbauarm, links	Kat.2	Arm l.h.	Bras gauche
4	8405.45.01	1	Anbauarm, rechts	Kat.3 kurz (short, court)	Arm r.h.	Bras droit
4	8405.45.02	1	Anbauarm, links	Kat.3 kurz (short, court)	Arm l.h.	Bras gauche
4	8405.46.01	1	Anbauarm, rechts	Kat.3	Arm r.h.	Bras droit
4	8405.46.02	1	Anbauarm, links	Kat.3	Arm l.h.	Bras gauche
5	931D1655N	4	Sechskantschraube	M16x55 DIN931-10.9	Hex. bolt	Vis 6 pans
6	127DB16A	4	Federring	B16 DIN127 vz.	Springwasher	Rondelle grower
7	934D16PA	4	Sechskantmutter	M16 DIN934-8 verz.	Hex. nut	Ecrou 6 pans
8	8405.12.08	2	Griff	TB-12x70	Handle	Broche
9	8405.12.09	2	Klappstecker	STB-4,5x340	Linch-pin	Goupille auto.
10	8405.40.00	1	Verstellstück		Adjuster	Pièce de réglage
11	763D0,656K13	2	Kette	0,656m-13 DIN763	Chain	Chaine
12	1481D636	2	Spannstift	6x36 DIN1481	Dowel Pin	Goupille serrage
13	82101DF1-1,6	2	Bügel	F1-1,6 DIN82101	Fastener	Support
14	931D2075P	2	Sechskantschraube	M20x75 DIN931-8.8	Hex. bolt	Vis 6 pans
15	936D20P	2	Sechskantmutter	M20 DIN936-8	Hex. nut	Ecrou 6 pans
16-20	8411.34.00	1	SPANNSCHLOSS		TURNBUCKLE	TIRANT
17-20	8409.36.00	1	SPANNSCHLOSS		TURNBUCKLE	TIRANT
16	8411.34.01	1	Spannschloßmutter	LPM-27x600	Turnbuckle nut	Ecrou tendeur
17	8409.36.01	1	Spannschloßmutter	LPM-27x800	Turnbuckle nut	Ecrou tendeur
18	6329.06.03	1	Ösenschraube	M27x240 L	Eyebolt	Piton
19	6329.06.04	1	Ösenschraube	M27x240	Eyebolt	Piton
20	4722.20.03	1	Kontermutter rechts		Counternut	Contre-écrou
21	8413.35.01	2	Turmbolzen verzinkt		Pin	Axe
22	1481D840A	4	Spannstift	8x40 DIN1481 vz.	Dowel Pin	Goupille serrage
23	7512.08.00	2	Steckstock TB-25X85 A	Steckstock TB-25X85 A	Pin	Axe
24	4716.35.00	2	Federsteckstock	BTB-4	R-clip	Goupille beta
25	8413.34.00	1	Turmanlenkung		Link arm	Bras réglable

2213_M

Drill-Lift
Drill-Lift
Drill-Lift

Corvus PKE Br.5, Corvex P Br.6

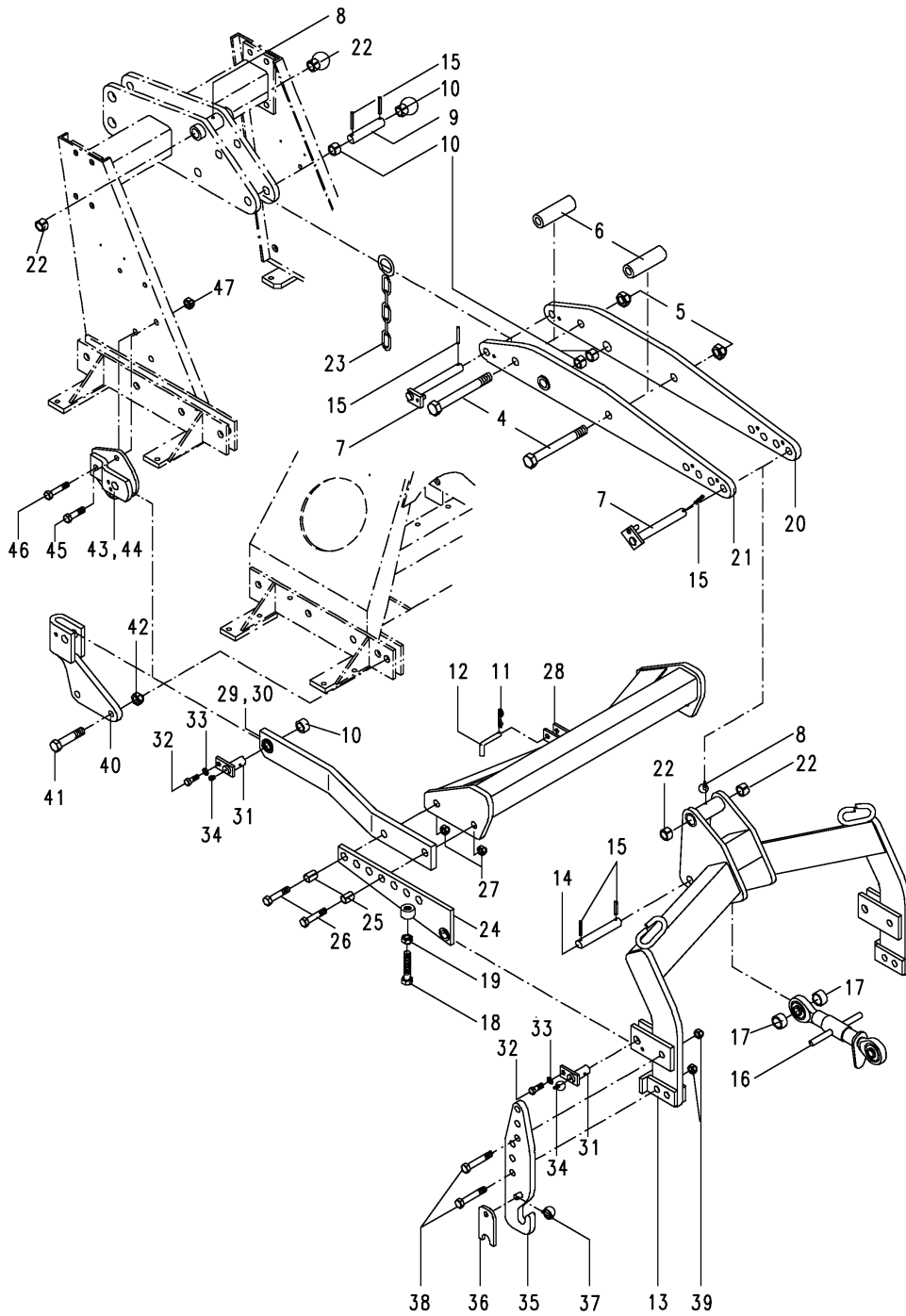

2213_M

 Drill-Lift
 Drill-Lift
 Drill-Lift

Corvus PKE Br.5, Corvex P Br.6

Bild Ref. Fig.	Bestellnr. Part-No. Référence	Stck. Qty. Qte.	Bezeichnung	Technische Angaben Technical data Données techniques	Description	Désignation
4	931D24200P	2	Sechskantschraube	M24x200 DIN931-8.8	Hex. bolt	Vis 6 pans
5	980DV24P	2	Sicherungsmutter	VM24 DIN980-8	Lock nut	Ecrou frein
6	7606.14.03	2	Distanzrohr		Spacer	Entretoise
7	8405.58.00	2	Hubbolzen verzinkt		Pin	Axe
8	4716.38.00	2	Schmiernippel	H1 8x1 KX-1	Grease nippel	Graisser
9	8413.35.01	1	Turmbolzen verzinkt		Pin	Axe
10	1498D253220	6	Buchse	EG 25/32x20 DIN1498	Bush	Douille
11	4716.35.00	1	Federsteckstock	BTB-4	R-clip	Goupille beta
12	6241.29.02	1	Steckstock	TB-12x50	Pin	Axe
13	7606.12.01	1	Hubturm		Lift headstock	Potence de relevage
14	7520.10.01	1	Lagerbolzen		Shaft	Axe
15	1481D840A	6	Spannstift	8x40 DIN1481 vz.	Dowel Pin	Goupille serrage
16	9108.78.01	1	Oberlenker	280-335	Top link	Axe 2 points
17	7606.14.04	2	Buchse		Bush	Douille
18	933D20100P	2	Sechskantschraube	M20x100 DIN933-8.8	Hex. bolt	Vis 6 pans
19	934D20PA	2	Sechskantmutter	M20 DIN934-8 vz.	Hex. nut	Ecrou 6 pans
20	7606.10.01	1	Hubarm, rechts		Lift arm r.h.	Bras interm. droit
21	7606.10.02	1	Hubarm, links		Lift arm l.h.	Bras interm. gauche
22	1498D253228	6	Buchse	EG 25/32x28 DIN1498	Bush	Douille
23	7606.13.01	1	Sicherungskette kpl.		Safety chain cpl.	Chainette de securité cpl.
24	7606.15.01	1	Verstellstück, links		Link arm l.h.	Bras gauche
24	7606.15.02	1	Verstellstück, rechts		Link arm r.h.	Bras droit
25	7002.05.00	4	Spannstift mit Wellenschlitz	25x32	Dowel pin	Goupille serrage
26	931D2075N	4	Sechskantschraube	M20x75 DIN931-10.9	Hex. bolt	Vis 6 pans
27	980DV20P	4	Sicherungsmutter	VM20 DIN980-8	Lock nut	Ecrou frein
28	7606.16.01	1	Querrohr		Cross bar	Tube transversal
29	7606.09.02	1	Seitenarm, links		Side arm l.h.	Bras laterale gauche
30	7606.09.01	1	Seitenarm, rechts		Side arm r.h.	Bras laterale droit
31	8413.38.00	4	Verstellarmbolzen verz.		Pin	Axe
32	933D1225NA	4	Sechskantschraube	M12x25 DIN933-10.9 vz.	Hex. bolt	Vis 6 pans
33	127DA12A	4	Federring	A12 DIN127 vz.	Springwasher	Rondelle grower
34	71412DB81	4	Schmiernippel	BM8x1 DIN71412	Grease nippel	Graisser
35	7606.11.01	1	Anlenkung, rechts	Kat. 2	Link arm r.h.	Bras réglable droit
35	7606.11.02	1	Anlenkung, links	Kat. 2	Link arm l.h.	Bras réglable gau.
35	7606.11.03	1	Anlenkung, rechts	Kat. 3	Link arm r.h.	Bras réglable droit
35	7606.11.04	1	Anlenkung, links	Kat. 3	Link arm l.h.	Bras réglable gau.
36	6336.72.01	2	Riegel	Kat. 2	Latch	Verrou
36	6336.72.02	2	Riegel	Kat. 3	Latch	Verrou

2213_M

Drill-Lift
Drill-Lift
Drill-Lift

Corvus PKE Br.5, Corvex P Br.6

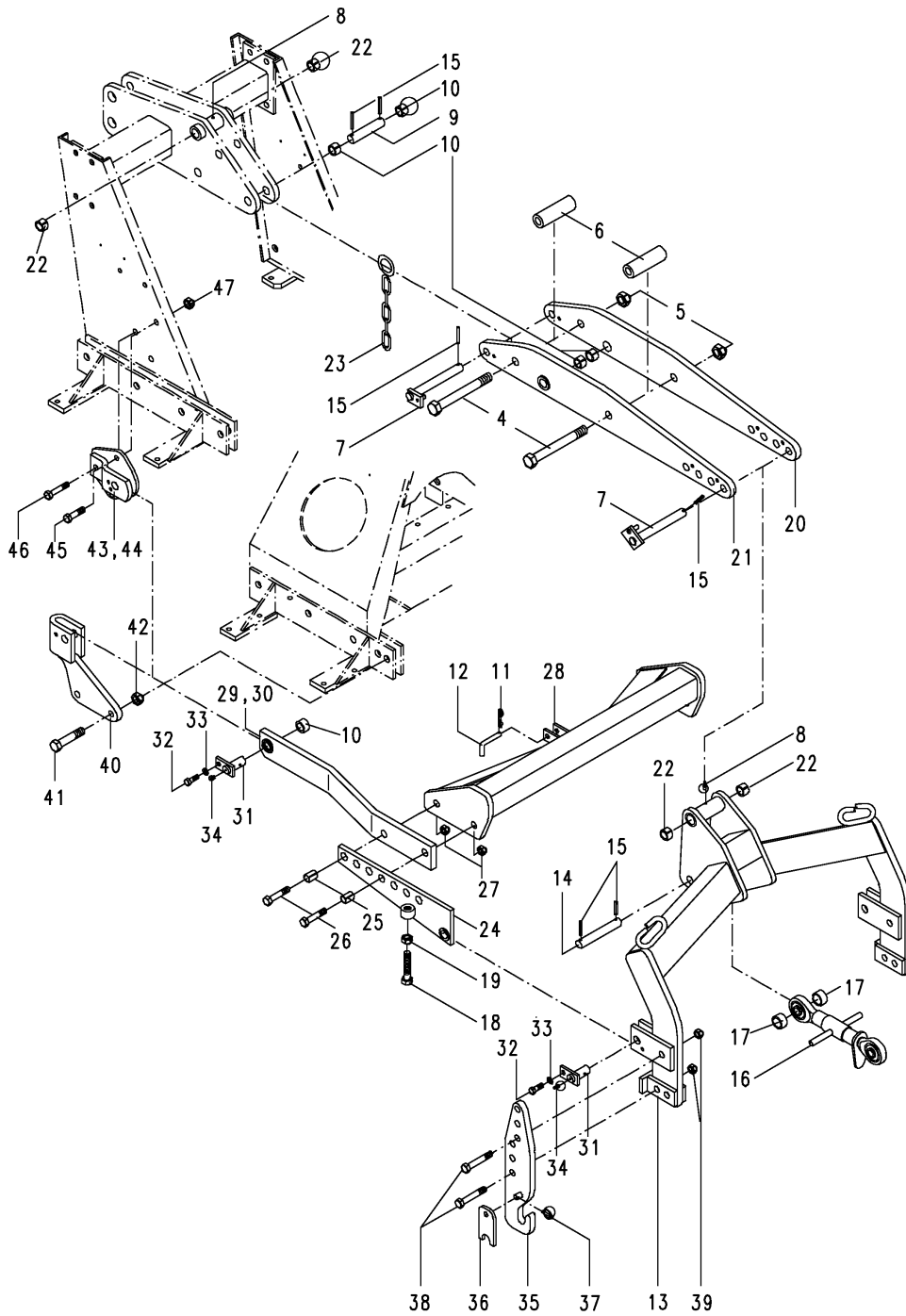

2213_M

 Drill-Lift
 Drill-Lift
 Drill-Lift

Corvus PKE Br.5, Corvex P Br.6

Bild Ref. Fig.	Bestellnr. Part-No. Référence	Stck. Qty. Qte.	Bezeichnung	Technische Angaben Technical data Données techniques	Description	Désignation
37	8405.12.09	2	Klappstecker	STB-4,5x340	Linch-pin	Goupille auto.
38	960D201590N	4	Sechskantschraube	M20x1,5x90 DIN960-10.9	Hex. bolt	Vis 6 pans
39	980DV2015N	4	Sicherungsmutter	VM20x1,5 DIN980-10	Lock nut	Ecrou frein
40	8435.15.01	1	Lagerbock, links		Bracket l.h.	Support gauche
40	8435.15.04	1	Lagerbock, rechts		Bracket r.h.	Support droit
41	960D201570N	4	Sechskantschraube	M20x1,5x70 DIN960-10.9	Hex. bolt	Vis 6 pans
42	980DV2015N	4	Sicherungsmutter	VM20x1,5 DIN980-10	Lock nut	Ecrou frein
43	7606.27.01	1	Halteflasche, links		Latch l.h.	Plat gauche
44	7606.27.02	1	Halteflasche, rechts		Latch r.h.	Plat droit
45	960D161545N A	4	Sechskantschraube	M16x1,5x45 DIN960-10.9 vz.	Hex. bolt	Vis 6 pans
46	960D161560M	2	Sechskantschraube	M16x1,5x60 DIN960-12.9	Hex. bolt	Vis 6 pans
47	8405.00.18	6	Poly-Stop-Sechskantmutter	M16x1,5	Poly-Stop nut	Ecrou Poly-Stop

2213_N

Hydraulischer Aushub
Hydraulic lifting
Relevage hydraulique

Corvus PKE Br.5, Corvex P Br.6

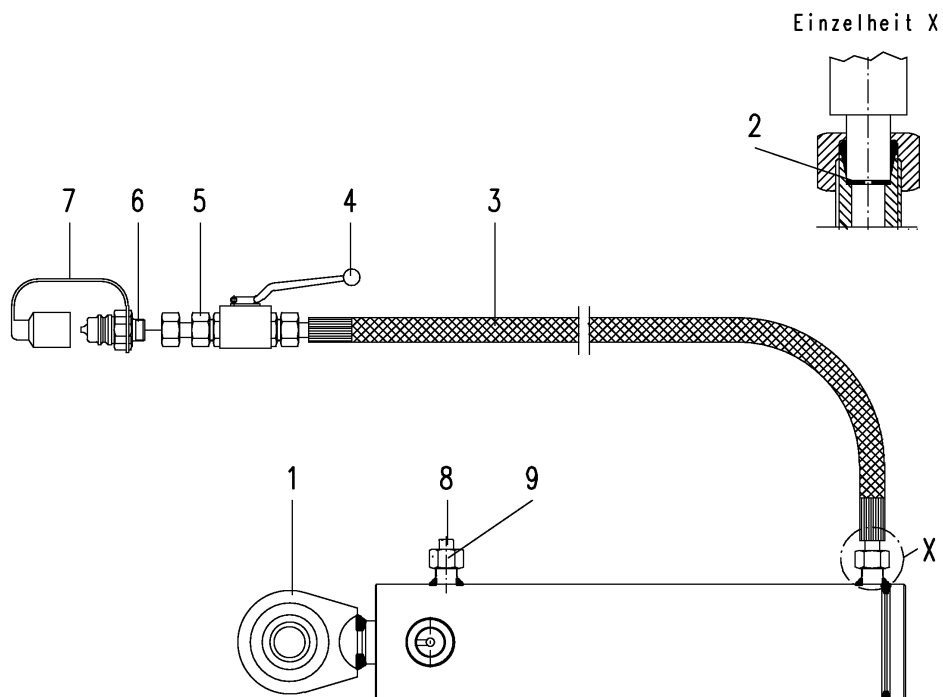

2213_N

 Hydraulischer Aushub
 Hydraulic lifting
 Relevage hydraulique

Corvus PKE Br.5, Corvex P Br.6

Bild Ref. Fig.	Bestellnr. Part-No. Référence	Stck. Qty. Qte.	Bezeichnung	Technische Angaben Technical data Données techniques	Description	Désignation
1-9	7606.06.01	1	HYDR. AUSHUB		HYDR. LIFTING	RELEVAGE HYDR.
1	8168.03.01	1	Zylinder	80/35/300	Cylinder	Verin
2	8132.06.04	1	Drosselscheibe	Ø2,5	Restrictive washer	Etranglement
3	8413.88.02	1	Hydraulikschlauch	L=1500 mm	Hydr. hose	Conduite flexible
4	4716.46.05	1	HD-Blockkugelhahn	NW-10	Ball valve	Robinet
5	4716.53.05	1	Hydraulikrohr kpl.	L=40 mm	Hydr.pipe cpl.	Tube cpl.
6	8132.01.00	1	Kupplungsstecker	ISO 5675	Coupling	Raccord
7	8132.05.01	1	Staubschutzkappe, rot		Dust cap red	Cache rouge
8	6432.58.23	1	Rohrverschlußbutzen	BUZ-12L/S	Nipple	Bouchon
9	4716.46.04	1	Überwurfmutter	M 12-L	Union nut	Ecrou-raccord

2213_O

Zylinder (hydr.Aushub)
Cylinder (hydr.lifting)
Verin (relevage hydr.)

Corvus PKE Br.5, Corvex P Br.6

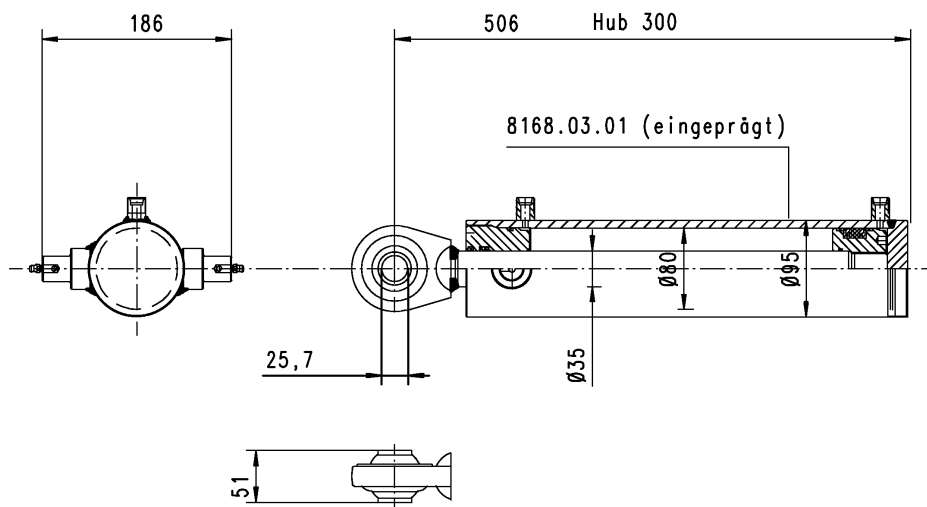

2213_O

Zylinder (hydr.Aushub)
Cylinder (hydr.lifting)
Verin (relevage hydr.)

Corvus PKE Br.5, Corvex P Br.6

Bild Ref. Fig.	Bestellnr. Part-No. Référence	Stck. Qty. Qte.	Bezeichnung	Technische Angaben Technical data Données techniques	Description	Désignation
	8168.03.01 8168.01.04		Zylinder Dichtungssatz	80/35/300	Cylinder Seal kit	Verin Jeu de joints

2213_P

Hubbegrenzung
Lift limiter
Butée de limit.de course

Corvus PKE Br.5, Corvex P Br.6

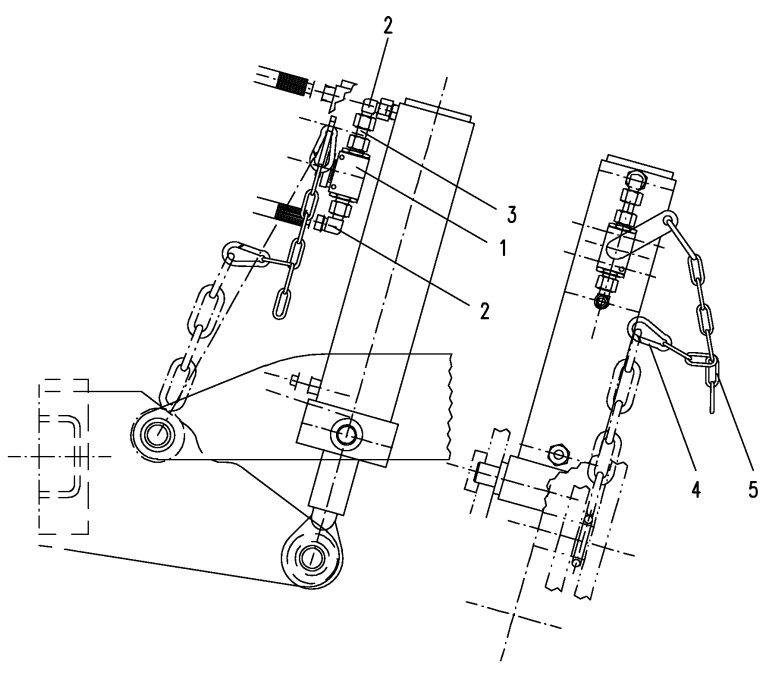

Nachrüstsatz

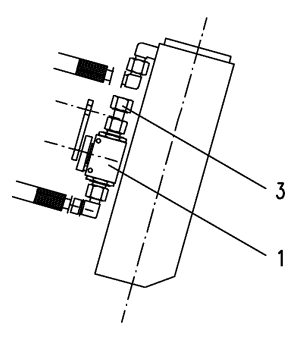

2213_P

 Hubbegrenzung
 Lift limiter
 Butée de limit.de course

Corvus PKE Br.5, Corvex P Br.6

Bild Ref. Fig.	Bestellnr. Part-No. Référence	Stck. Qty. Qte.	Bezeichnung	Technische Angaben Technical data Données techniques	Description	Désignation
1	8423.31.01	1	Hubbegrenzer		Lift limiter	Limiteur de levée
2	4716.52.11	2	Einstellb. Winkelverschraub.	EVW-12 L	Elbow coupling	Raccord
3	4716.53.05	1	Hydraulikrohr kpl.	L=40 mm	Hydr.pipe cpl.	Tube cpl.
4	8423.28.05	2	Feuerwehr-Karabinerhaken		Carbine swivel	Mousqueton
5	763D0,256K4	1	Kette	0,256 m DIN763-4	Chain	Chaîne
1-4	8423.80.05	1	NACHRÜST.HUBBEGR.		LIFT LIMITER KIT	KIT DE BUTEE LIMIT.

2213_R

Satteldreieck
A-frame (male)
Triangle d'attelage

Corvus PKE Br.5, Corvex P Br.6

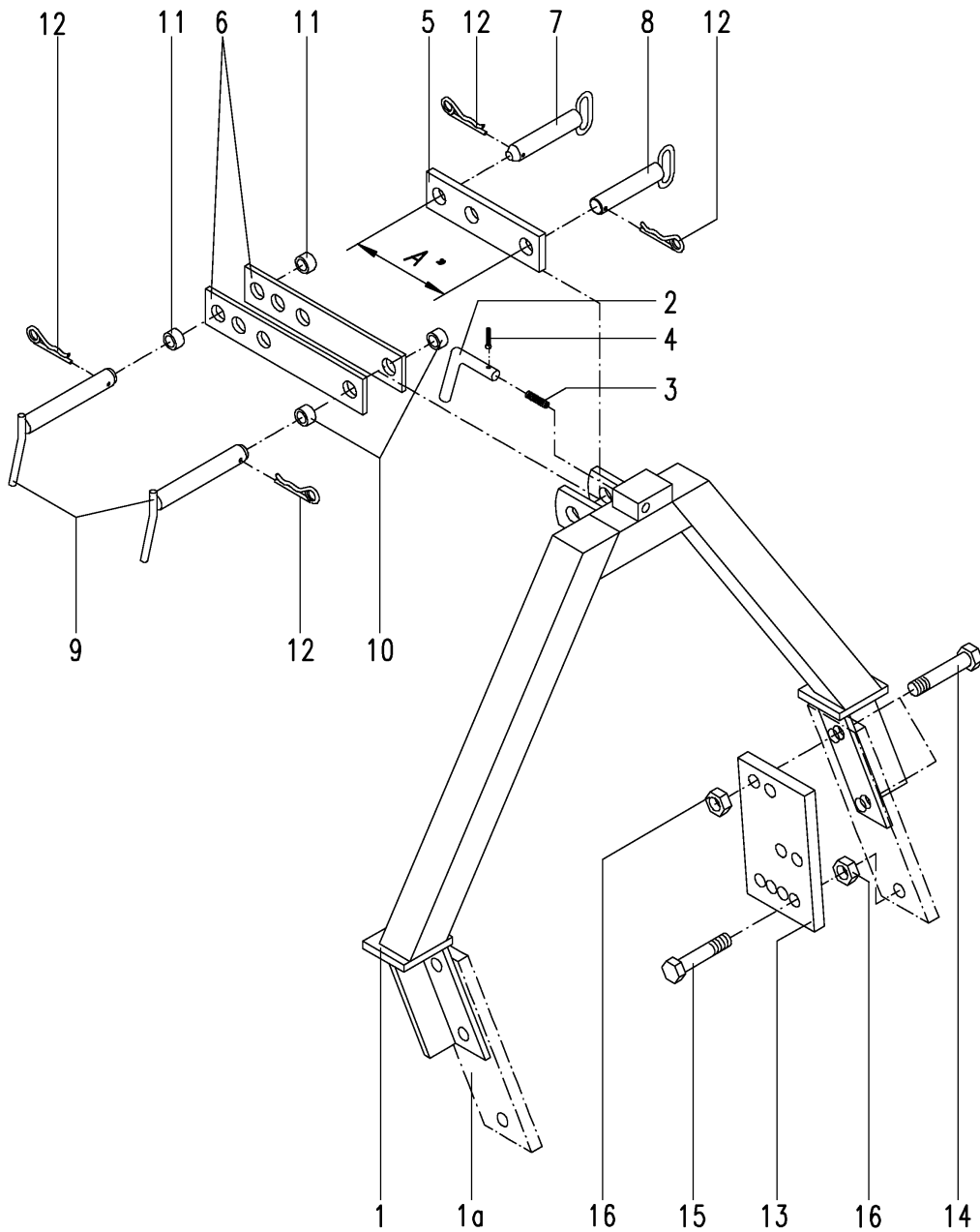

2213_R

 Satteldreieck
 A-frame (male)
 Triangle d'attelage

Corvus PKE Br.5, Corvex P Br.6

Bild Ref. Fig.	Bestellnr. Part-No. Référence	Stck. Qty. Qte.	Bezeichnung	Technische Angaben Technical data Données techniques	Description	Désignation
1	8426.30.00	1	Satteldreieck		A-frame (male)	Triangle d'attelage
1a	8426.31.00	1	Satteldreieck	MKE-Schaltgetr.	A-frame (male)	Triangle d'attelage
2	8412.55.05	1	Steckbolzen		Pin	Axe
3	8412.55.06	1	Druckfeder verzinkt		Compression spring	Ressort
4	8412.55.07	1	Spannstift	6x40 DIN1481 verz.	Dowel Pin	Goupille serrage
5	8419.03.01	1	Oberlenkerstrebe	A=170 mm (EMKE, WMKE)	Top link	Support
6	8412.55.02	2	Oberlenkerstrebe	A=222 mm (MKE-Schaltgetr., SKE)	Top link	Support
6	8412.55.03	2	Oberlenkerstrebe	A=262 mm	Top link	Support
6	8412.55.08	2	Oberlenkerstrebe	A=252 mm (MKE)	Top link	Support
6	8435.24.02	2	Oberlenkerstrebe	A=292 (CKE)	Top link	Support
6	8432.55.04	2	Oberlenkerstrebe	A=270 mm	Top link	Support
7	2614.18.00	1	Zugbolzen verzinkt		Pin	Axe
8	8007.13.00	1	Steckstock	TB-25x110 A	Pin	Axe
9	8404.74.00	2	Steckstock	TB-25x170 A	Pin	Axe
10	8412.55.04	2	Distanzrohr		Spacer	Entretoise
11	1498D253228	2	Buchse	EG 25/32x28 DIN1498	Bush	Douille
12	4716.35.00	2	Federsteckstock	BTB-4	R-clip	Goupille beta
13	8412.55.10	2	Verstellplatte		Adjust. Plate	Plaque de réglage
14	933D2050P	4	Sechskantschraube	M20x50 DIN933-8.8	Hex. bolt	Vis 6 pans
15	931D2070P	2	Sechskantschraube	M20x70 DIN931-8.8	Hex. bolt	Vis 6 pans
16	980DV20PA	6	Sicherungsmutter	VM20 DIN980-8 vz.	Lock nut	Ecrou frein

2213_S

Beleuchtungseinrichtung
Rear light kit
Kit d'éclairage

Corvus PKE Br.5, Corvex P Br.6

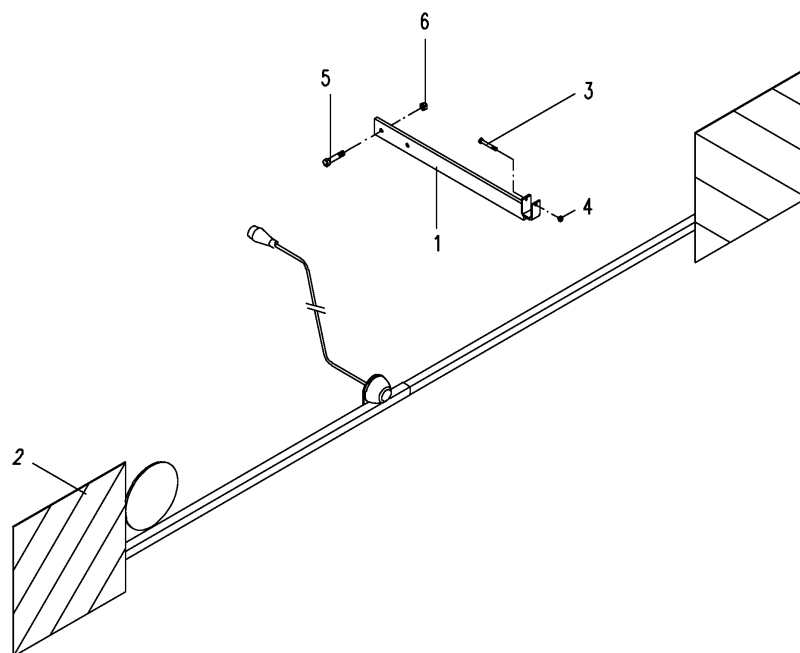

2213_S

 Beleuchtungseinrichtung
 Rear light kit
 Kit d'éclairage

Corvus PKE Br.5, Corvex P Br.6

Bild Ref. Fig.	Bestellnr. Part-No. Référence	Stck. Qty. Qte.	Bezeichnung	Technische Angaben Technical data Données techniques	Description	Désignation
1	8433.22.01	2	Leuchenträger		Indic. bracket	Support éclairage
2	6456.60.00	1	Stangenrückleuchte		Rear lights	Barre d'éclairage
3	931D855PA	2	Sechskantschraube	M8x55 DIN931-8.8 vz.	Hex. bolt	Vis 6 pans
4	315D8RA	2	Flügelmutter	M8 DIN315-5 vz.	Wing nut	Ecrou à ailettes
5	933D1230N	4	Sechskantschraube	M12x30 DIN933-10.9	Hex. bolt	Vis 6 pans
6	980DV12NA	4	Sicherungsmutter	VM12 DIN980-10 vz.	Lock nut	Ecrou frein

2213_T

Segment-Schutzschiene hinten
 Protection bar rear
 Barre de protection arrière

Corvus PKE Br.5, Corvex P Br.6

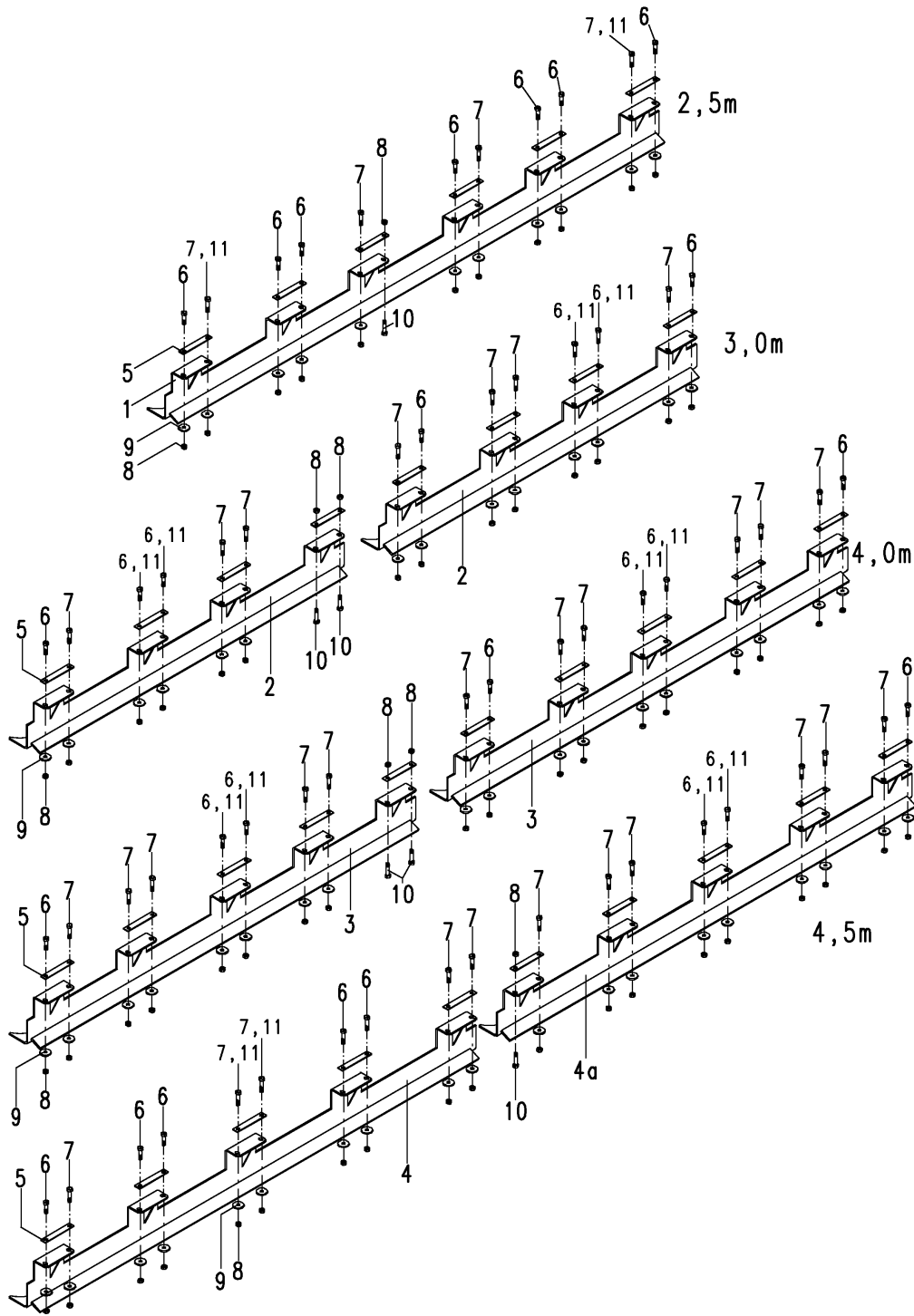

2213_T

 Segment-Schutzschiene hinten
 Protection bar rear
 Barre de protection arrière

Corvus PKE Br.5, Corvex P Br.6

Bild Ref. Fig.	Bestellnr. Part-No. Référence	Stck. Qty. Qte.	Bezeichnung	Technische Angaben Technical data Données techniques	Description	Désignation
1	8435.23.02	1	Schutzschiene hinten	2,5 m	Protection bar	Barre de protection
2	8435.23.03	2	Schutzschiene hinten	3,0 m	Protection bar	Barre de protection
3	8435.23.07	2	Schutzschiene hinten	4,0 m	Protection bar	Barre de protection
4	8435.23.09	1	Schutzschiene hinten links	4,5 m	Protection bar rear	Barre de protect.arrière
4a	8435.23.10	1	Schutzschiene hinten rechts	4,5 m	Protection bar rear	Barre de protect.arrière
5	8411.00.29		Unterlage		Shim	Cale
6	931D1245M		Sechskantschraube	M12x45 DIN931-12.9	Hex. bolt	Vis 6 pans
7	931D1255M		Sechskantschraube	M12x55 DIN931-12.9	Hex. bolt	Vis 6 pans
8	980DV12M		Sicherungsmutter	VM12 DIN980-12	Lock nut	Ecrou frein
9	7349D13A		Scheibe	13 DIN7349 vz.	Washer	Rondelle
10	8426.13.03		Verbus-Ripp-Sechskantschraube	M12x45-100	Verbus-Ripp bolt	Boulon hex. indesserable
11	931D1265M		Sechskantschraube	M12x65 DIN931-12.9	Hex. bolt	Vis 6 pans

2213_U

Aufbausatz für ME(L)-A
Hitch for ME(L)-A
Kit adaption pour ME(L)-A

Corvus PKE Br.5, Corvex P Br.6

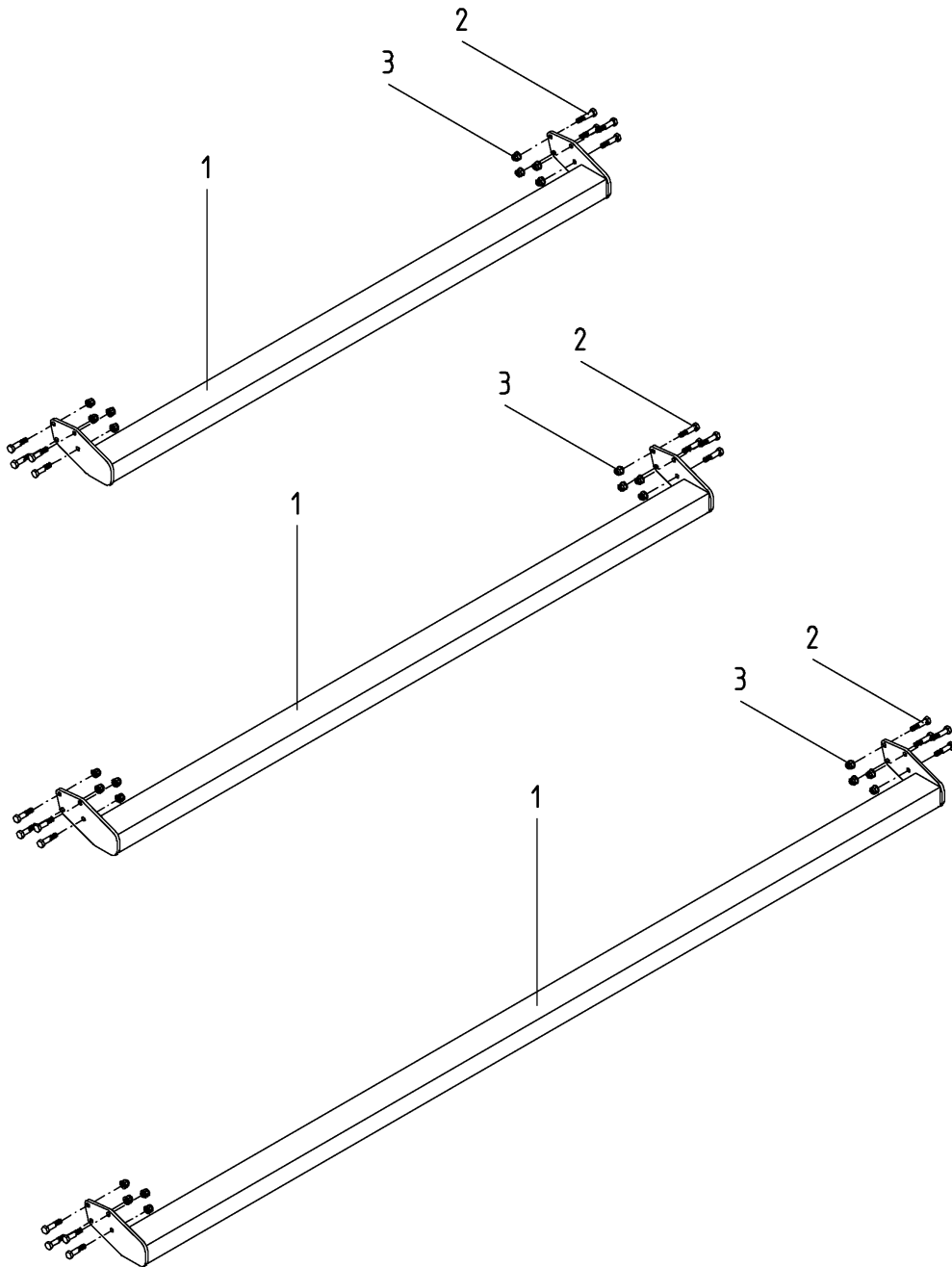

2213_U

 Aufbausatz für ME(L)-A
 Hitch for ME(L)-A
 Kit adaption pour ME(L)-A

Corvus PKE Br.5, Corvex P Br.6

Bild Ref. Fig.	Bestellnr. Part-No. Référence	Stck. Qty. Qte.	Bezeichnung	Technische Angaben Technical data Données techniques	Description	Désignation
1	8437.79.02	1	Querträger	Corvus/Corvex PKE, VKE 3,0m	Bracket	Support
1	8437.79.04	1	Querträger	Corvus/Corvex PKE 4,0m	Bracket	Support
1	8437.79.05	1	Querträger	Corvus/Corvex VKE 4,0m	Bracket	Support
2	960D161580M	8	Sechskantschraube	M16x1,5x80 DIN960-12.9	Hex. bolt	Vis 6 pans
3	8405.00.18	8	Poly-Stop-Sechskantmutter	M16x1,5	Poly-Stop nut	Ecrou Poly-Stop
	RIPA1		Bei (Mulch)-Rillenpackerwalze	RIPA 580, RIPA-M 600	For wetch-ring roller	Pour rouleau sillonneur
1	8437.87.02	1	Querträger	Corvus/Corvex PKE, VKE 3,0m	Bracket	Support
1	8437.87.04	1	Querträger	Corvus/Corvex PKE 4,0m	Bracket	Support
1	8437.87.05	1	Querträger	Corvus/Corvex VKE 4,0m	Bracket	Support
2	960D161580M	8	Sechskantschraube	M16x1,5x80 DIN960-12.9	Hex. bolt	Vis 6 pans
3	8405.00.18	8	Poly-Stop-Sechskantmutter	M16x1,5	Poly-Stop nut	Ecrou Poly-Stop

2213_V

Frontanbau
Front mounting
Montage poussée

Corvus PKE Br.5, Corvex P Br.6

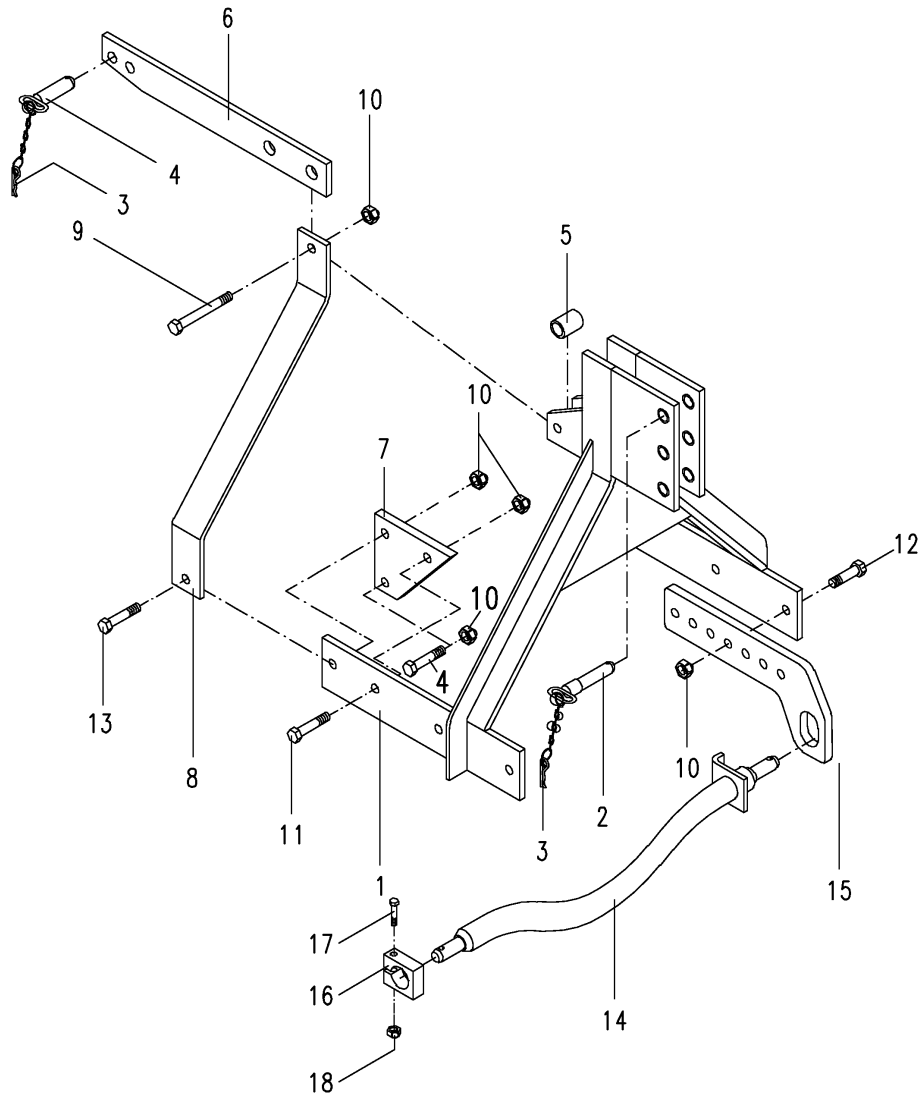

2213_V

 Frontanbau
 Front mounting
 Montage poussée

Corvus PKE Br.5, Corvex P Br.6

Bild Ref. Fig.	Bestellnr. Part-No. Référence	Stck. Qty. Qte.	Bezeichnung	Technische Angaben Technical data Données techniques	Description	Désignation
1	8406.65.00	1	Frontturm		Front headstock	Tête
2	6333.09.00	1	Ol-Stock	Kat.2	Top link pin	Axe 3 points
3	4716.35.00	2	Federsteckstock	BTB-4	R-clip	Goupille beta
4	8007.13.00	1	Steckstock	TB-25x110 A	Pin	Axe
5	8406.54.01	1	Distanzhülse		Spacer	Bague entretoise
6	8406.54.05	1	Turmstrebe	MKE -Br.2, EMKE,WMKE,LR	Strut	Support
7	8406.54.07	2	Anschraubplatte	MKE Br.3+, PKE,SKE,R+SR	Connecting plate	Plaque a visser
8	8406.54.03	2	Haltestrebe		Strut	Support
9	931D20140P	1	Sechskantschraube	M20x140 DIN931-8.8	Hex. bolt	Vis 6 pans
10	980DV20PA	11	Sicherungsmutter	VM20 DIN980-8 vz.	Lock nut	Ecrou frein
11	931D2065P	2	Sechskantschraube	M20x65 DIN931-8.8	Hex. bolt	Vis 6 pans
12	933D2060P	6	Sechskantschraube	M20x60 DIN933-8.8	Hex. bolt	Vis 6 pans
13	931D2075P	2	Sechskantschraube	M20x75 DIN931-8.8	Hex. bolt	Vis 6 pans
14	8406.66.00	1	Dreipunktachse	Kat.2	3-point shaft	Axe 3-points
15	8435.19.10	2	Anschlußschiene		Connecting rail	Porte à visser
16	8413.00.41	1	Klemmstück		Clamp plate	Pièce de serrage
17	931D1280M	1	Sechskantschraube	M12x80 DIN931-12.9	Hex. bolt	Vis 6 pans
18	934D12M	1	Sechskantmutter	M12 DIN934-12	Hex. nut	Ecrou 6 pans

Für Kunde
for customer
pour client

Rabewerk

Kundenzeichnungs-Nr.
Customer drawing No.
Réf. du plan client

8433.25.01

Maschinenart
Machine
Machine

Kreislegge

Type
Type
Type

VKE 300

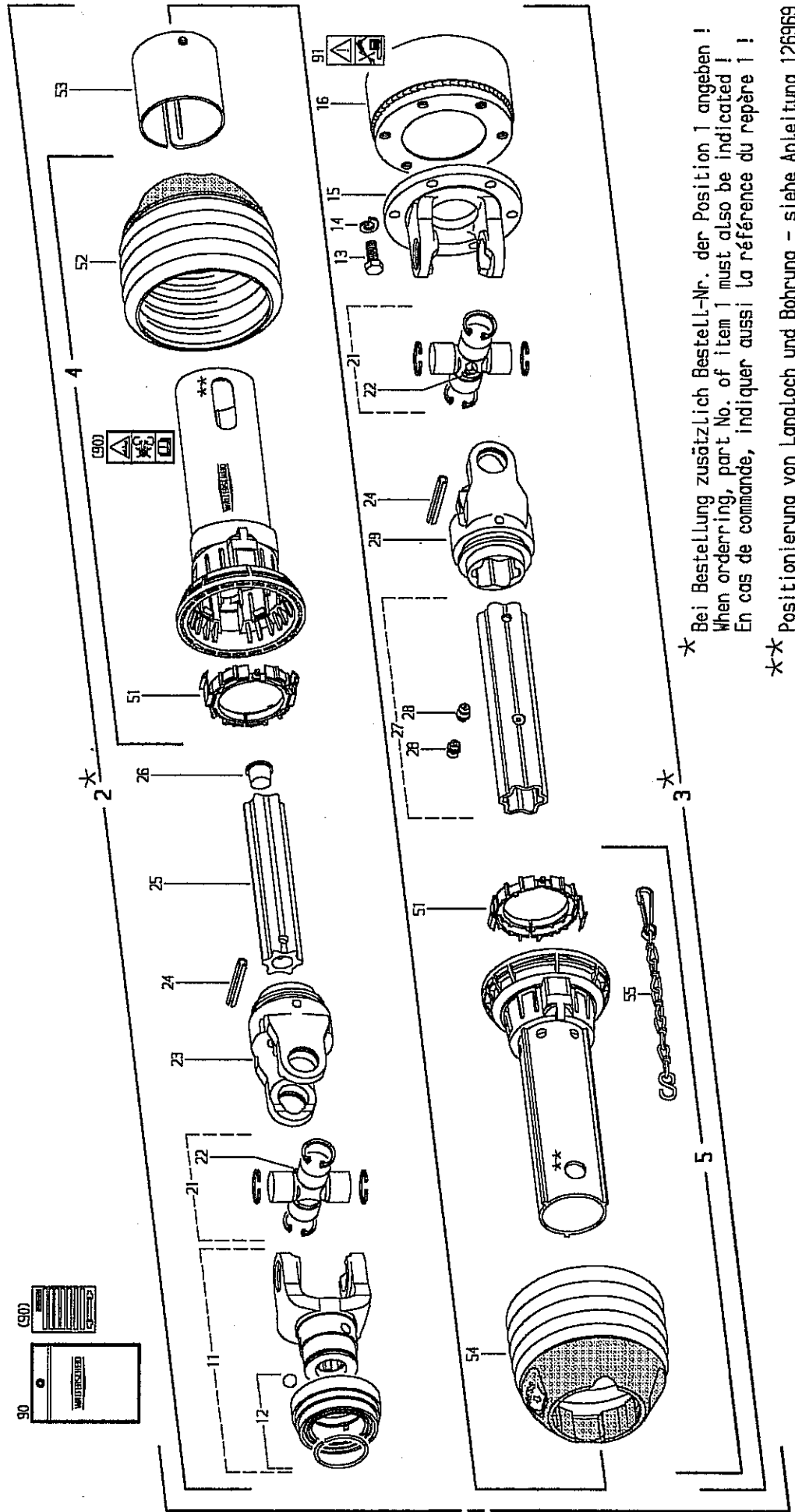

* Bei Bestellung zusätzlich Bestell-Nr. der Position 1 angeben !
When ordering, part No. of item 1 must also be indicated !
En cas de commande, indiquer aussi la référence du repère 1 !

** Positionierung von Langloch und Bohrung - siehe Anleitung 126969
Slot and hole positioning - see instructions 126969
Positionnement du trou oblong et du trou - voir notice 126969

Pos.-Nr. Item Réfère	GMN Wellenscheid Part No. Reference	Zeichnungs-Nr. Drawing No. Réf. du Plan	Stückzahl Quantity Quantité	Technische Angaben Technical data Données techniques	Benennung	Description	Désignation
1	129825	16449	1	P500-P620-760-K64/22R	Gelenkwelle mit Schutz	PTO drive shaft with guard	Transmission avec protecteur
2*			1	PH500-P620-678	Innere Gelenkwellenhälfte mit äußerer Schutzhälfte	Inner PTO drive shaft half with outer guard half	Demi-transmission intérieure avec demi-protecteur extérieur
3*			1	PH500-P620-653-K64/22R	Äußere Gelenkwellenhälfte mit innerer Schutzhälfte	Outer PTO drive shaft half with inner guard half	Demi-transmission extérieure avec demi-protecteur intérieur
4	116126	86.202	1	PH20-A1000-RP5	Äußere Schutzhälfte	Outer guard half	Demi-protecteur extérieur
5	116127	86.201	1	PH20-J1000-RP5-K	Innere Schutzhälfte	Shorten P6 tube by 495 mm	Raccourcir tube P6 de 495 mm
					PG-Rohr 495 mm kürzen	Shorten P6 tube by 495 mm	Raccourcir tube P6 de 495 mm
					PG-Trichter 1 Rippe(n) kürzen	Shorten P6 cone by 1 rib(s)	Raccourcir cone P6 de 1 onde(s)
11	366798	36.83.00	1	Q562500-1 3/8" (G)	Q5-Gabel komplett	Q5-yoke complete	Mâchoire Q5 complète
12	376106	agra-set. 123	1		Q5-Verschluß komplett; Größe C	Q5-Lock complete; size C	Verrouillage Q5 complet; type C
13	020531	60.06.05	6	D1N933-M12x30	Sechskantschraube	Hexagon screw	Boulon hexagonal
14	020106	60.83.00	6	D1N127-M12	Federring	Lock washer	Rondelle élastique
15	317807	36.19.02	1	F62500-TK138/12(G)	Flanschgabel	Flange yoke	Mâchoire à bride
16	129931	59.107.43	1	EK64/22R-1 3/4" (G)CC- TK138/M12(G); H=2000Nm	Nockenschaltkupplung; Rechtsdrehinn	Cam-type cut out clutch; right-hand rotation	Limiteur débrayable à comes; rotation à droite
21	121145	36.00.03	2		Kreuzgarnitur komplett	Cross and bearing kit complete	Bloc croisillon complet
22	084099	63.27.00	2	BR6x1	Kegel-Schmiernippel	Lubrication fitting	Graisseur
23	125356	36.13.21	1	R6 P500-54	Rillengabel	Inboard yoke	Mâchoire à gorge
24	304046	61.05.12	2	1508752-10x50	Spannstift	Spring-type straight pin	Soupille élastique
25	134357	75.44.21	1	S4V-680	Profilwelle; vergütet Rohr 60 mm kürzen	Profile shaft; tempered Shorten tube by 60 mm	Arbre profilé; trempé et revenu Raccourcir tube de 60 mm
26	043535	68.13.22	1	25 S	Koppe	Plug	Bouchon
27	119992	75.45.187	1	55H-595	Profilrohr mit Schmiernippel	Profile tube with lubrication fitting	Tube profilé avec graisseur
28	043427	63.11.02	2	AM6	Kegel-Schmiernippel	Lubrication fitting	Graisseur
29	125321	36.14.21	1	R6 P500-55	Rillengabel	Inboard yoke	Mâchoire à gorge
51	117229	86.20.00	2		Gleitring	Bearing ring	Bague de glissement
52	120025	86.24.05	1	n-RP5	Schutzrichter; n= Rippenanzahl	Guard cone; n= Number of ribs	Cône protecteur; n= Nombre d'ondes
53	198303	80.64.102	1		Abdeckung	Cover	Obturateur
54	120025	86.24.05	1	n-RP5	Schutzrichter; n= Rippenanzahl PG-Trichter 1 Rippe(n) kürzen	Guard cone; n= Number of ribs Shorten P6 cone by 1 rib(s)	Cône protecteur; n= Nombre d'ondes Raccourcir cone P6 de 1 onde(s)
55	044321	82.36.03	1		Haltekette	Safety chain	Chaînette
90	120777	agra-set. 209	1		Bedienungsanleitung (West) und GEFÄHRENHEITS-Aufkleber	Service instructions (West) and WARNING decal	Notice d'emploi (Ouest) et étiquette d'avertissement
91	117291	16.61.181	1		Verbotsaufkleber - Hochdruckreiniger	Prohibitive decal - high-pressure cleaner	Autocollant d'interdiction nettoyeur à haute pression



Kupplung
Clutch
Limiteur

EK64/22R-1 3/4" (6)CC-
TK138/M12 (6); M=2000Nm

Bestell-Nr.
Part No.
Référence

129931

Zeichnungs-Nr.
Drawing No.
Réf. du plan

59.107.43

Datum
Date

06.11.2003

Seite
Page

1

von
of
de

Für Kunde
for customer
pour client

Rabewerk

Kundenzeichnung-Nr.
Customer drawing No.
Réf. du plan client

Maschinenart
Machine
Machine

Type
Type
type

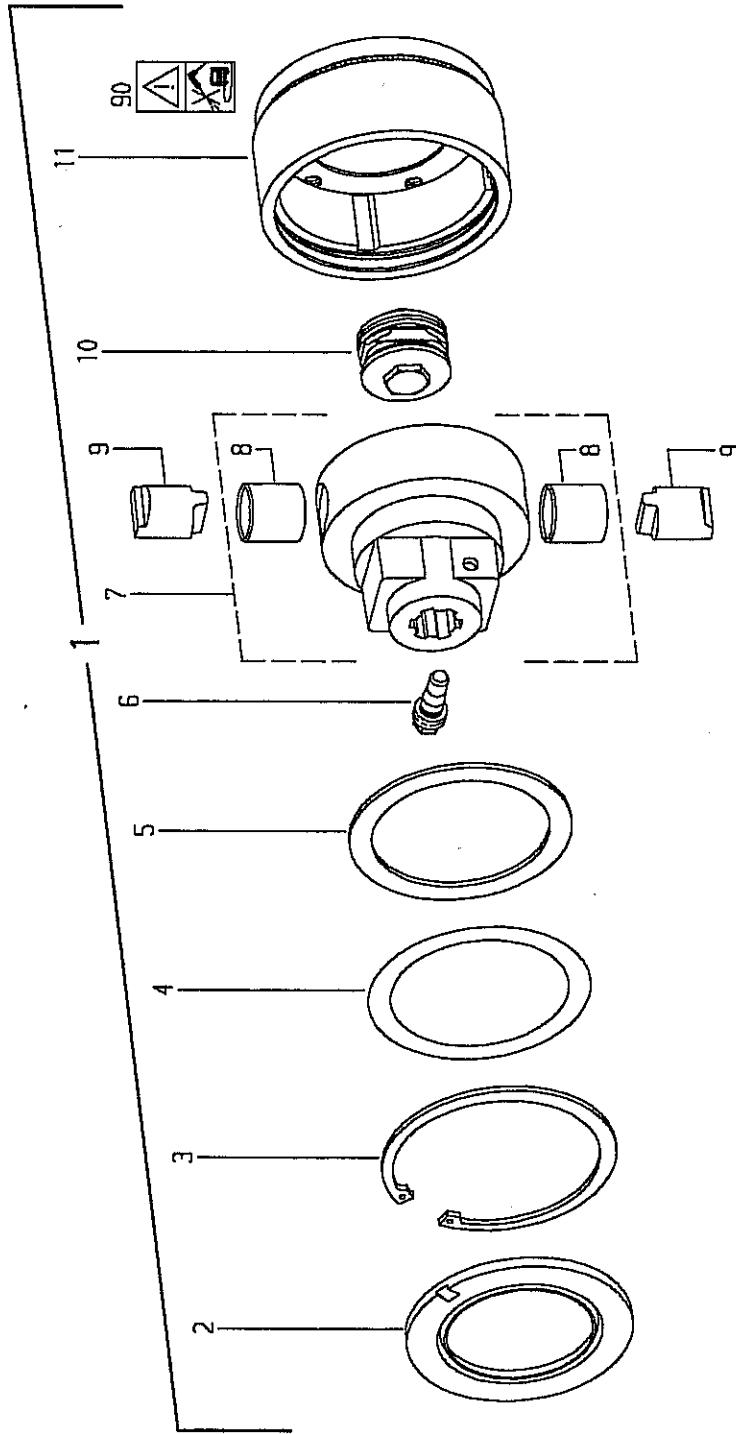

Pos.-Nr. Item Réfère	GKN Motorschild Bestell-Nr. Part No. Référence	Zeichnungs-Nr. Drawing No. Réf. au Plan	Robevark Bestell-Nr. Part No. Référence	Stückzahl Quantity Quantité	Technische Angaben Technical data Données techniques	Benennung	Description	Désignation
1	129931	59.107.43		1	EK64/22R-1 3/4" (6) CC- TK138/M12 (6); H=2000Nm	Nockenschaltkupplung; Rechtsdrehs inn	Cam-type cut out clutch; right-hand rotation	Limiteur débrayable à comes; rotation à droite
2	161459	68.18.01		1	152.5x59x8	Dichtring	Sealing ring	Joint
3	364499	62.46.00		1	DIN472-150x4	Sicherungsring	Retaining ring	Jonc
4	116143	agraaset 152				Paßscheiben-Satz		Jeu de rondelles de calage
5	364621	16.20.81		1	5120x150x3,5	Stützscheibe	Supporting ring	Rondelle pour bague de frein
6	107542	65.12.08		1	CC 1 3/4"	Klemm-Konus	Clamping cone	Cône de contrainte
7	128510	59.26.02		1	K64/22-1 3/4" (6) CC	Nabe komplett	Hub complete	Moyeu complet
8	128519	16.50.618		2	35x39x35	Buchse	Bush	Douille
9	127120	59.29.01		2	ø35	Sperrirocken	Locking cam	Came de blocage
10	129941	59.27.04		1	K64/22-MD200	Federpaket, montiert	Spring pack assembly	Bloc-ressort complet
11	129781	59.22.07		1	EK64/22-24R-TK138/M12 (6)	Kupplungsgehäuse; Rechtsdrehs inn	Clutch housing; right-hand rotation	Boîtier; rotation à droite
90	117291	16.61.181		1		Verbotsaufkleber - Hochdruckreintiger	Prohibitive decal -	Autocollant d'interdiction
	304291	agraaset 116		1	50 g	Spezialfett	Special grease	Lubrifiant spécial



Gelenkwelle
PTO drive shaft
Transmission

Bestell-Nr.
Part No.
Référence

Zeichnungs-Nr.
Drawing No.
Réf. du plan

Datum
Date
Date

Seite
Page
Page

von
of
de

für Kunde
for customer
pour client

Rabewerk

Kundenzeichnung-Nr.
Customer drawing No.
Réf. du plan client

Maschinenart
Machine
Machine

Kreiselegge

Type
Type
Type

PKE Rotor, SK 300-600

SR 250-400

Anschlußvariante-Schlepperseite
Connection variants-tractor side
Versions d'accouplement-côté tracteur

QSG250-

a = 1 3/8" (6)
b = 1 3/8" (21)
c = 1 3/4" (6)
d = 1 3/4" (20)

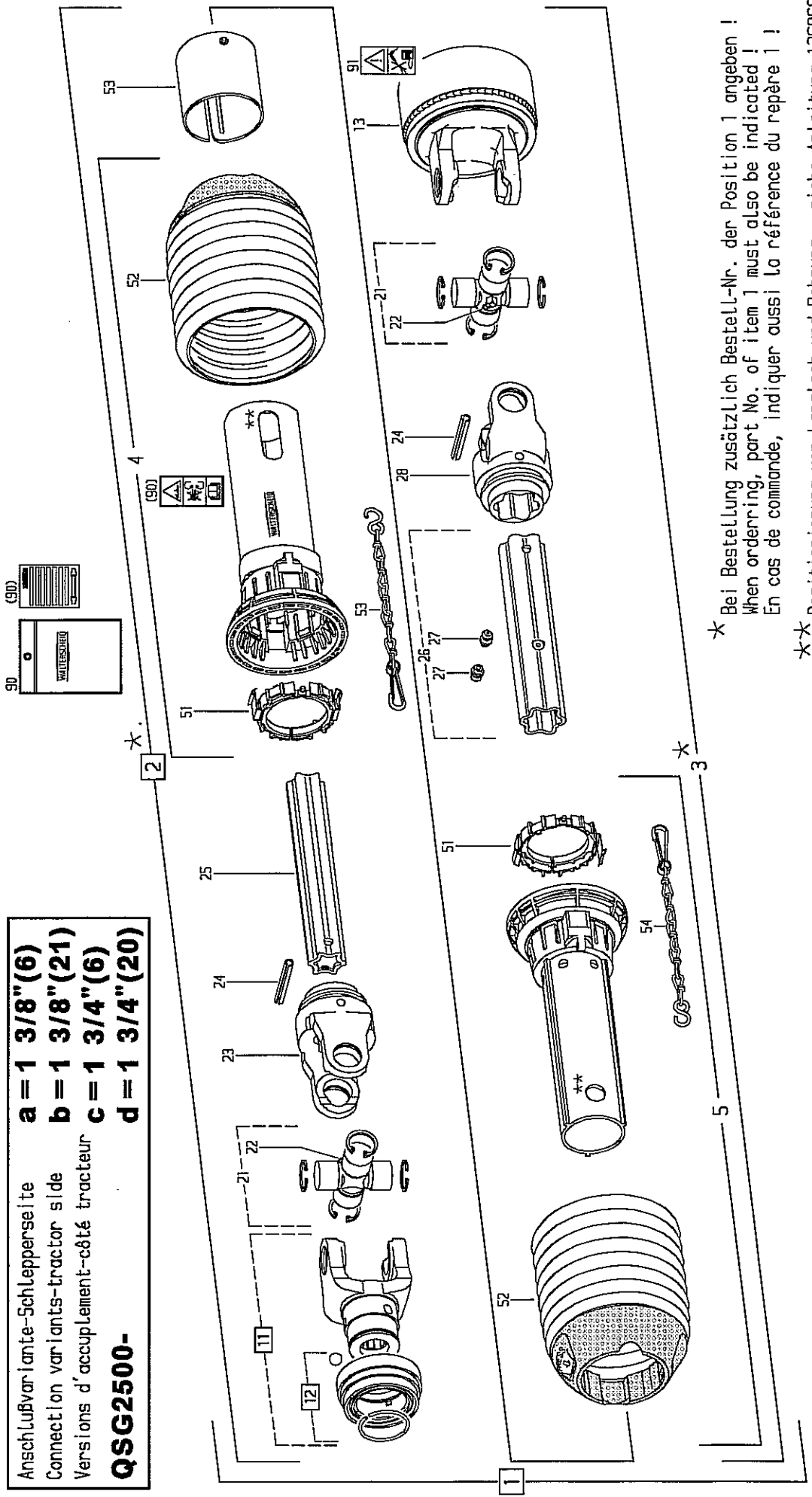

* Bei Bestellung zusätzlich Bestell-Nr. der Position 1 angeben !
When ordering, part No. of item 1 must also be indicated !
En cas de commande, indiquer aussi la référence du repère 1 !

** Positionierung von Langloch und Bohrung - siehe Anleitung 126969
Slot and hole positioning - see instructions 126969
Positionnement du trou oblong et du trou - voir notice 126969



Gelenkwelle
PTO drive shaft
Transmission

Bestell-Nr.
Part No.
Référence

Zeichnungs-Nr.
Drawing No.
Réf. du plan

Datum
Date
Date

Seite
Page
Page

von
of
de

P600-P630-760-K64/22R

06.11.2003

2

Pos.-Nr. Item Réfère	GKN Walterscheid Bestell-Nr./ Drawing No. Réf. du Plan	Rabewenk Bestell-Nr. Part No. Référence	Stückzahl Quantity Quantité	Technische Angaben Technical data Données techniques	Benennung	Description	Désignation
1a	129821 16445	8433-26.01	1	P600-P630-760-K64/22R	Gelenkwelle mit Schutz	PTO drive shaft with guard	Transmission avec protecteur
1b	129822 16446	8433-26.02	1	P600-P630-760-K64/22R			
1c	129823 16447	8433-26.03	1	P600-P630-760-K64/22R			
1d	129824 16448	8433-26.04	1	P600-P630-760-K64/22R			
2a	*		1	PH600-P630-647	Innere Gelenkwellenhälfte mit äußerer Schutzhälfte	Inner PTO drive shaft half with outer guard half	Demi-transmission intérieure avec demi-protecteur extérieur
2b	*		1	PH600-P630-647			
2c	*		1	PH600-P630-647			
2d	*		1	PH600-P630-647			
3	*		1	PH600-P630-627-K64/22R	Äußere Gelenkwellenhälfte mit innerer Schutzhälfte	Outer PTO drive shaft half with inner guard half	Demi-transmission extérieure avec demi-protecteur intérieur
4	116129 86.302		1	P6H30-A1000-RPB	Äußere Schutzhälfte PG-Rohr 560 mm kürzen PG-Trichter 1 Rippe(n) kürzen	Outer guard half Shorten PG tube by 560 mm Shorten PG cone by 1 rib(s)	Demi-protecteur extérieur Raccourcir tube PG de 560 mm Raccourcir cône PG de 1 onde(s)
5	116130 86.301		1	P6H30-J1000-RPB-K	Innere Schutzhälfte PG-Rohr 560 mm kürzen PG-Trichter 1 Rippe(n) kürzen	Inner guard half Shorten PG tube by 560 mm Shorten PG cone by 1 rib(s)	Demi-protecteur intérieur Raccourcir tube PG de 560 mm Raccourcir cône PG de 1 onde(s)
11a	365814 26.84.00 +		1	0562600-1 3/8" (6)	05-Gabel komplett	05-yoke complete	Mâchoire 05 complète
11b	365816 26.84.02 +		1	0562600-1 3/8" (21)			
11c	365818 26.84.04 +		1	0562600-1 3/4" (6)			
11d	366780 26.84.06 +		1	0562600-1 3/8" (20)			
12a+b	376106 agraset 123		1	1 3/8"	05-Verschluß komplett; Größe C	05-Lock complete; size C	Verrouillage 05 complet; type C
12c+d	376107 agraset 124		1	1 3/4"	Hockenschaltkupplung; Rechtsdrehinn	Com-type cut out clutch; right-hand rotation	Limiteur débrayable à comes; rotation à droite
13	129930 59.106.43		1	K64/22R-2600-1 3/4" (6) CC; M=2350Nm	Kreuzgarnitur komplett	Cross and bearing kit complete	Bloc croissillon complet
21	121146 26.00.03		2		Kegel-Schmiernippel	Lubrication fitting	Graisser
22	084099 63.27.00		2	BMBx1	Rillengabel	Inboard yoke	Mâchoire à gorge
23	119927 26.13.30 +		1	RG P600-55	Spannstift	Spring-type straight pin	Goupille élastique
24	304578 61.06.08		2	1508752-13x95	Profilrohr; gehärtet	Profile tube; hardened	Tube profilé; cémenté
25	179711 75.45.139		1	55H-580	Profilrohr mit Schmiernippel	Profile tube with lubrication fitting	Tube profilé avec graisseur
26	179713 75.46.102		1	56-560	Schlag-Schmiernippel	Drive-in type lubrication fitting	Graisser à fropper
27	380371 63.33.00		2	4, 6	Rillengabel	Inboard yoke	Mâchoire à gorge
28	119928 26.14.30 +		1	RG P600-56			
51	100000 66.20.00		1				

Kupplung
Clutch
Limiteur



K64/22R-2600-1 3/4" (6)CC; M=2350Nm

Bestell-Nr.
Part No. **129930**
Réf. du plan

Zeichnungs-Nr.
Drawing No. **59.106.43**

Datum
Date **06.11.2003**

Seite von
Page 1 of 1
Page 1 de 1

Für Kunde
for customer
pour client

Rabewerk

Kundenzeichnung-Nr.
Customer drawing No.
Réf. du plan client

Maschinenname
Machine
Machine

Type
Type
Type

