

Bestell-Nr. 9900.00.91DE10
(Bestell-Nr. Betriebsanleitung 9900.00.13DE01)

--	--	--	--	--	--	--	--	--

Ihre Maschinen-Nr.

Ersatzteilliste

Kreiseleggen

PKE 250, 300 Br. 8

PKE 400, 450 Br. 9



Ersatzteilliste



Inhaltsverzeichnis
Contents
Sommaire

PKE 250, 300 Br.8
PKE 400, 450 Br.9

A	Turm, Werkzeugträger	Headstock, trough	Tête, caisson
B	Seitenblech, Walzen	Side plate, rollers	Tôle de laterale, rouleaux
C	Wechselradgetriebe, Antrieb	Gearbox, drive	Boîte de vitesse, entrainem.
D	Schaltgetriebe	Lever gearbox	Boîtier à selecteur
E	Dreipunktgestänge, mechan.	Rear hitch mechan.	Attelage 3 points mechan.
F	Drill-Lift	Rear hitch "Drill-Lift"	Attelage "Drill-Lift"
G	Hydraulischer Aushub	Hydraulic lifting	Relevage hydraulique
G1	Zylinder 8168.03.01	Cylinder	Verin
H	Hubbegrenzung	Lift limiter	Butée de limit.de course
J	Frontanbau	Front mounting	Montage poussée
K	Satteldreieck	A-frame (male)	Triangle d'attelage
L	Leitblech	Deflector	Deflecteur
M	Prallblech	Clod bar	Chicane
N	Segment-Schutzschiene hinten	Protection bar rear	Barre de protection arrière
O	Radspurlockerer	Eradicator	Effaceur de trace
O1	Träger für Radspurlockerer	Bracket for eradicator	Support pour effaceur
P	Radspurlockerer RAMAT	Eradicator "RAMAT"	Effaceur "RAMAT"
	GLW2500-SD25-760-K90/4R	PTO drive shaft	Transmission
	GLW2500-SD25-760-EK64/2R	PTO drive shaft	Transmission
	GLW2600-SD35-610-K96/4	PTO drive shaft	Transmission
	GLW2600-SD35-610-K64/2R	PTO drive shaft	Transmission
	Reibkupplung K90/4R	Clutch	Limiteur
	Reibkupplung K96/4	Clutch	Limiteur
	Nockenschaltk. (E)K64/2R	Clutch	Limiteur

Ersatzteilliste



A

Turm, Werkzeugträger
 Headstock, trough
 Tête, caisson

PKE 250,300 Br.7-8, PKE 400,450 Br.8-9

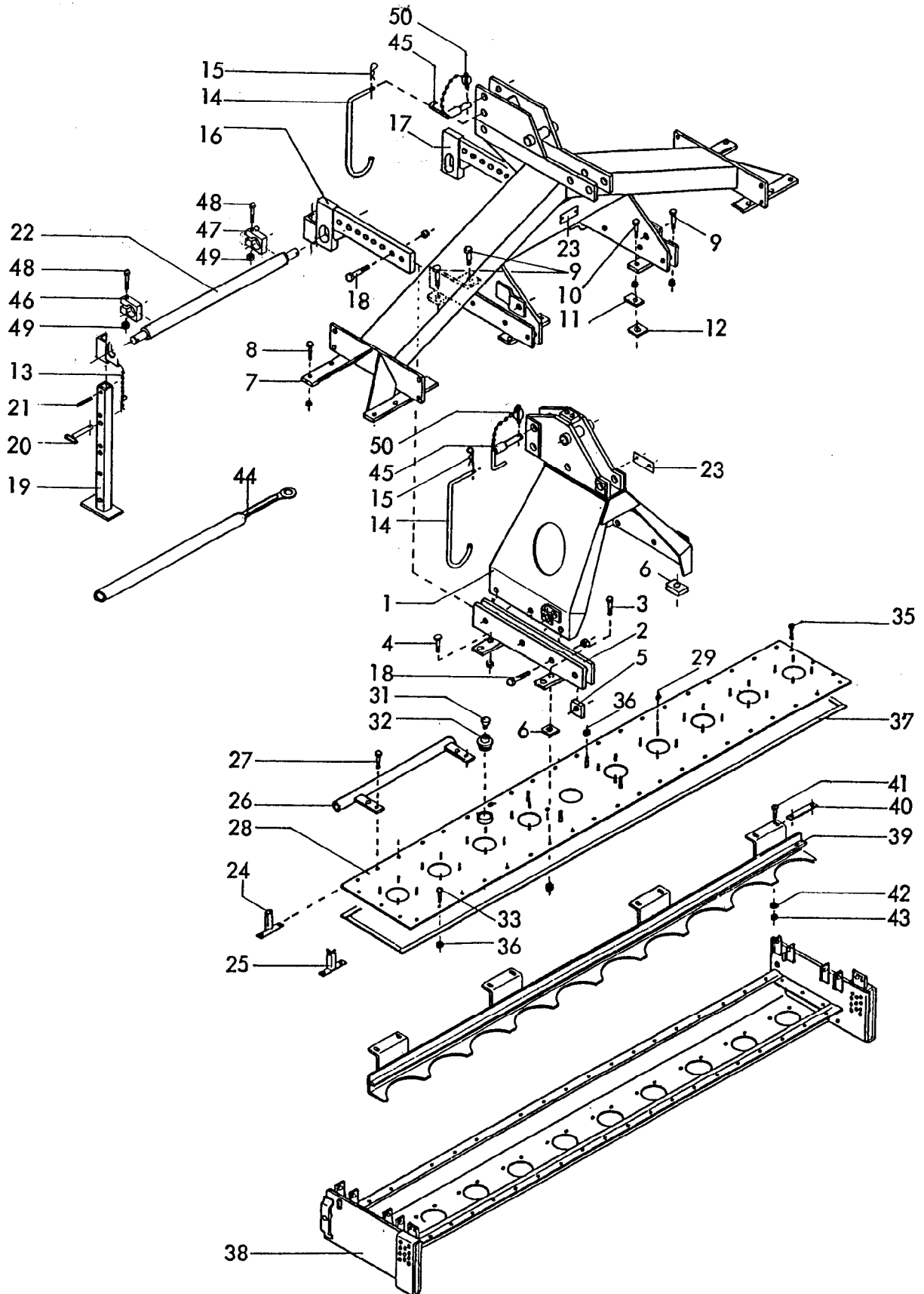

Ersatzteilliste



A

Turm, Werkzeugträger
Headstock, trough
Tête, caisson

PKE 250, 300 Br.7-8
PKE 400, 450 Br.8-9

Bild Ref. Fig.	Bestellnr. Part.-No. Référence	Stck Qty. Qte.	Bezeichnung	Technische Angaben Technical data Données techniques	Description	Désignation
1	8413.16.00	1	Turm		Headstock	Tête
2	8427.17.01	1	Turmhalterung, rechts		Bracket, r.h.	Support, droit
2	8427.17.02	1	Turmhalterung, links		Bracket, l.h.	Support, gauche
2	8413.19.01	1	Turmhalterung, rechts		Bracket, r.h.	Support, droit
2	8413.19.02	1	Turmhalterung, links		Bracket, l.h.	Support, gauche
3	933D1245M	6	Sechskantschraube	M12x45 DIN933-12.9	Hex. Bolt	Vis 6 pans
4	931D1265M	2	Sechskantschraube	M12x65 DIN931-12.9	Hex. bolt	Vis 6 pans
4	931D1280M	2	Sechskantschraube	M12x80 DIN931-12.9	Hex. bolt	Vis 6 pans
4	980DV12M	12	Sicherungsmutter	VM12 DIN980-12	Lock nut	Ecrou frein
5	8413.00.34	2	Distanzplatte		Spacer plate	Entretoise
6	8413.00.31	2	Distanzstück		Spacer	Entretoise
6	8413.00.43	2	Distanzplatte		Spacer plate	Entretoise
7	8427.28.00	1	Dreipunktbock		3-point hitch	Tourelle
8	931D1245M	11	Sechskantschraube	M12x45 DIN931-12.9	Hex. bolt	Vis 6 pans
9	931D1265M	8	Sechskantschraube	M12x65 DIN931-12.9	Hex. bolt	Vis 6 pans
9	980DV12M	19	Sicherungsmutter	VM12 DIN980-12	Lock nut	Ecrou frein
10	931D1280M	2	Sechskantschraube	M12x80 DIN931-12.9	Hex. bolt	Vis 6 pans
10	980DV12M	2	Sicherungsmutter	VM12 DIN980-12	Lock nut	Ecrou frein
11	8413.00.43	2	Distanzplatte		Spacer plate	Entretoise
12	8412.40.01	2	Scheibe	S=0,5 mm	Washer	Rondelle
12	8412.40.02	2	Scheibe	S=1,0 mm	Washer	Rondelle
13	4716.35.00	1	Federsteckstock	BTB-4	R-clip	Goupille beta
14	8405.00.19	1	Bügel		Fastener	Support
15	8418.00.04	1	Vorsteckfeder	BTB-40	R-Clip	Goupille beta
16	8431.21.01	1	Anschlußstück		Connecting bracket r.h.	Support à visser, droit
17	8411.04.04	1	Anschlußstück		Connecting bracket l.h.	Support à visser, gauche
18	960D201570N	4/6	Sechskantschraube	M20x1,5x70 DIN960-10.	Hex. bolt	Vis 6 pans
18	980DV2015N	4/6	Sicherungsmutter	VM20x1,5 DIN980-10	Lock nut	Ecrou frein
19	8431.31.01	1	Abstellstütze		Stand	Bequille
20	8424.33.00	1	Steckstock	TB-20x90 A	Pin	Axe
21	1481D1360	1	Spannstift	13x60 DIN1481	Dowel pin	Goupille serrage
22	8007.17.02	1	Dreipunktachse	Kat.2, DA-793	Cross shaft	Axe d'attelage
22	8007.17.05	1	Dreipunktachse	Kat.3, DA-75	Cross shaft	Axe d'attelage
22	8406.28.00	1	Dreipunktachse	Kat.3 kurz (short, court)	Cross shaft	Axe d'attelage
23	4716.37.00	1	Typenschild	SX-4	ID-plate	ID-plaque
23	1476D410	2	Halbrundkerbnagel	4x10 DIN1476	Rivet	Rivet

Ersatzteilliste

A

 Turm, Werkzeugträger
 Headstock, trough
 Tête, caisson

PKE 250, 300 Br.7-8
PKE 400, 450 Br.8-9

Bild Ref. Fig.	Bestellnr. Part.-No. Référence	Stck Qty. Qte.	Bezeichnung	Technische Angaben Technical data Données techniques	Description	Désignation
24	8409.32.00	2	Leuchtenhalter, vorn		Freont bracket	Support avant
25	8409.33.01	1	Leuchtenhalter hinten r		Rear bracket r.h.	Support AR/D
25	8409.33.02	1	Leuchtenhalter hinten li		Rear bracket l.h.	Support AR/G
26	8423.05.05	2	Beinschutz	PKE 250	Safety cover	Protecteur
26	8423.05.04	2	Beinschutz	MKE,SKE,PKE 300	Safety cover	Protecteur
26	8423.05.19	2	Beinschutz	PKE 350	Safety cover	Protecteur
26	8423.05.03	2	Beinschutz	MKE,SKE,PKE 400	Safety cover	Protecteur
26	8423.05.21	2	Beinschutz	PKE 450	Safety cover	Protecteur
27	933D1235N		Sechskantschraube	M12x35 DIN933-10.9	Hex. bolt	Vis 6 pans
27	980DV12N		Sicherungsmutter	VM12 DIN980-10	Lock nut	Ecrou frein
27	931D1255M	2	Sechskantschraube	M12x55 DIN931-12.9	Hex. bolt	Vis 6 pans
27	980DV12M	2	Sicherungsmutter	VM12 DIN980-12	Lock nut	Ecrou frein
28	8427.39.01	1	Abdeckblech	PKE 250	Endcap	Couvercle
28	8427.39.02	1	Abdeckblech	PKE 300	Endcap	Couvercle
28	8427.39.03	1	Abdeckblech	PKE 350	Endcap	Couvercle
28	8427.39.04	1	Abdeckblech	PKE 400	Endcap	Couvercle
28	8427.39.05	1	Abdeckblech	PKE 450	Endcap	Couvercle
29	980DV10N		Sicherungsmutter	VM10 DIN980-10	Lock nut	Ecrou frein
31	8404.47.00	1	Be-und Entlüftungsfilter		Breather	Reniflard
32	8404.24.00	1	Verschlußschraube	R 1 1/2"	Hexagon head plug	Bouchon
33	933D1225N		Sechskantschraube	M12x25 DIN933-10.9	Hex. bolt	Vis 6 pans
35	933D1230NVP	6	Verbus-Plus Schraube	M12X30 DIN933-10.9	Verbus-Plus bolt	Boulon hex. indesserable
36	980DV12N		Sicherungsmutter	VM12 DIN980-10	Lock nut	Ecrou frein
37	8409.31.14	1	Flachdichtung	15x4x5340 mm	Seal	Joint
37	8409.31.09	1	Flachdichtung	15x4x6290 mm	Seal	Joint
37	8409.31.15	1	Flachdichtung	15x4x7280 mm	Seal	Joint
37	8409.31.10	1	Flachdichtung	15x4x8280 mm	Seal	Joint
37	8409.31.16	1	Flachdichtung	15x4x9260 mm	Seal	Joint
38	8413.82.01	1	Werkzeugträger	PKE 250	Trough	Caisson
38	8413.82.02	1	Werkzeugträger	PKE 300	Trough	Caisson
38	8413.82.04	1	Werkzeugträger	PKE 350	Trough	Caisson
38	8413.82.03	1	Werkzeugträger	PKE 400	Trough	Caisson
38	8413.82.05	1	Werkzeugträger	PKE 450	Trough	Caisson
39	8413.20.01	1	Schutzschiene	PKE 250	Protection bar	Barre de protection
39	8413.20.03	1	Schutzschiene, rechts	PKE 300	Protection bar r.h.	Barre de protection droit
39	8413.20.02	1	Schutzschiene, links	PKE 300	Protection bar r.h.	Barre de protection droit
39	8413.20.13	1	Schutzschiene, rechts	PKE 350	Protection bar r.h.	Barre de protection droit
39	8413.20.12	1	Schutzschiene, links	PKE 350	Protection bar r.h.	Barre de protection droit

Ersatzteilliste

A

 Turm, Werkzeugträger
 Headstock, trough
 Tête, caisson

PKE 250, 300 Br.7-8
PKE 400, 450 Br.8-9

Bild Ref. Fig.	Bestellnr. Part.-No. Référence	Stck Qty. Qtye.	Bezeichnung	Technische Angaben Technical data Données techniques	Description	Désignation
39	8413.20.05	1	Schutzschiene, rechts	PKE 400	Protection bar r.h.	Barre de protection droit
39	8413.20.04	1	Schutzschiene, links	PKE 400	Protection bar r.h.	Barre de protection droit
39	8413.20.17	1	Schutzschiene, rechts	PKE 450	Protection bar r.h.	Barre de protection droit
39	8413.20.16	1	Schutzschiene, links	PKE 450	Protection bar r.h.	Barre de protection droit
40	8411.00.29	4	Unterlage		Shim	Cale
41	933D1245M	2	Sechskantschraube	M12x45 DIN933-12.9	Hex. Bolt	Vis 6 pans
42	6436.60.03	8	Scheibe	C-13	Washer	Rondelle
43	980DV12M	4	Sicherungsmutter	VM12 DIN980-12	Lock nut	Ecrou frein
44	8405.00.17	1	Ringschlüssel	SW 24	Ring spanner	Cle à moneau
45	8413.31.00	1	OL-Stock	Kat.2	Top link pin	Axe 3 points
45	8413.58.00	1	O.L.-Stock	Kat.3	Top link pin	Axe 3 points
46	8413.00.41	1	Klemmstück		Clamp plate	Pièce de serrage
47	8423.87.01	1	Klemmring		Clamping ring	Bague de serrage
48	931D1280M	2	Sechskantschraube	M12x80 DIN931-12.9	Hex. bolt	Vis 6 pans
49	934D12M	2	Sechskantmutter	M12 DIN934-12	Hex. nut	Ecrou 6 pans
50	6344.40.02	1	Sicherungskette kpl.		Safety chain cpl.	Chainette de securité

Ersatzteilliste



B

Seitenblech, Walzen
 Side plate, rollers
 Tôle de laterale, rouleaux

PKE 250,300 Br.7-8, PKE 400,450 Br.8-9

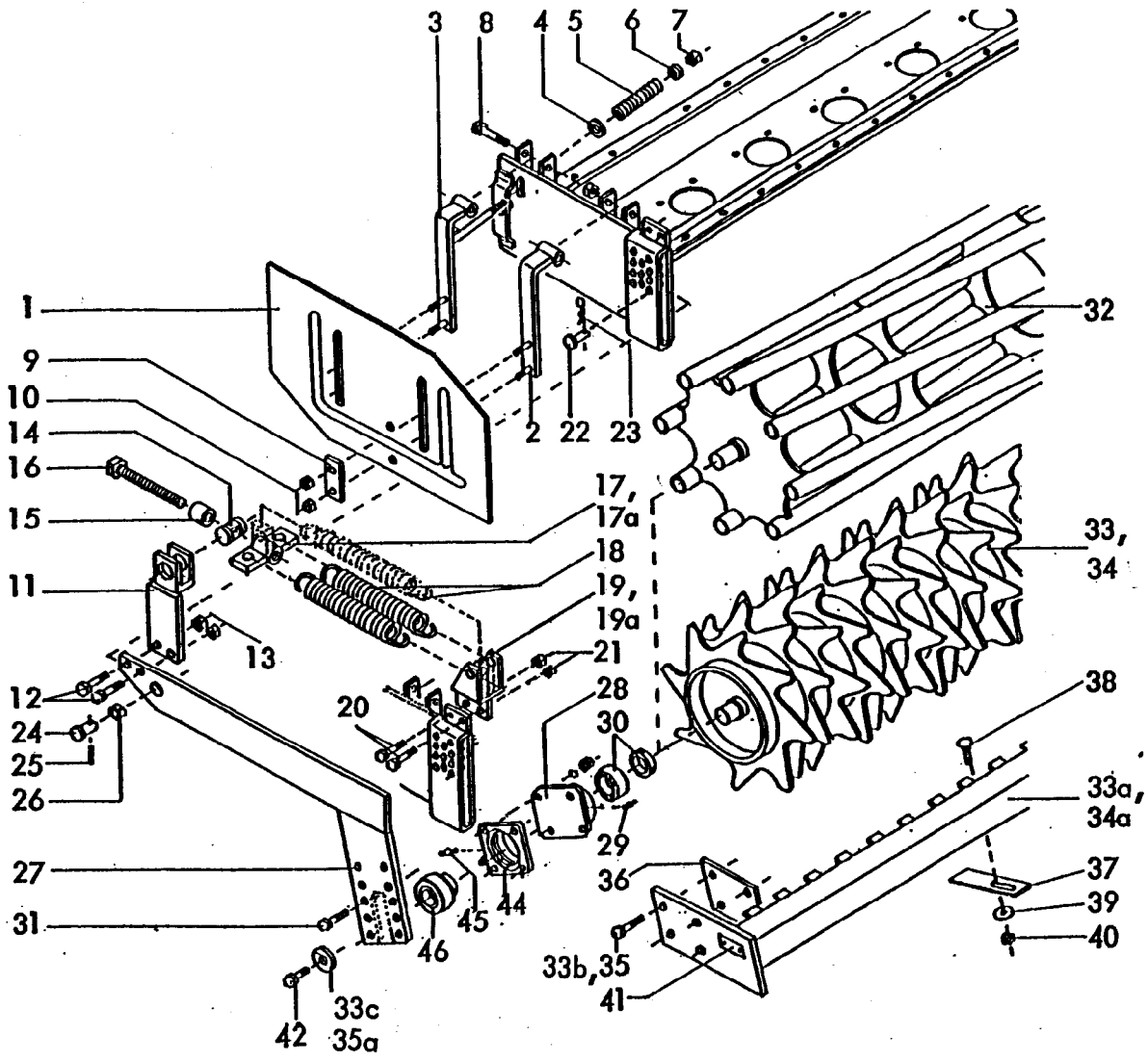

Ersatzteilliste

B

 Seitenblech, Walzen
 Side plate, rollers
 Tôle de laterale, rouleaux

PKE 250, 300 Br.7-8
PKE 400, 450 Br.8-9

Bild Ref. Fig.	Bestellnr. Part.-No. Référence	Stck Qty. Qte.	Bezeichnung	Technische Angaben Technical data Données techniques	Description	Désignation
1	8413.86.01	1	Seitenblech links		Side plate l.h.	Tôle laterale gauche
1	8413.86.02	1	Seitenblech rechts		Side plate r.h.	Tôle laterale droit
2	8413.84.00	2	Seitenblechhalter, hinte		Side plate arm rear	Bras de tôle laterale arriè
3	8413.85.00	2	Seitenblechhalter, vorn		Side plate arm front	Bras de tôle laterale avan
4	7518.00.02	2	Scheibe	C-170	Washer	Rondelle
5	8413.00.44	2	Druckfeder	DF-226	Compression spring	Ressort
6	126D18A	2	Scheibe	8 DIN126 verz.	Washer	Rondelle
7	980DV16P	2	Sicherungsmutter	VM16 DIN980-8	Lock nut	Ecrou frein
8	931D20110P	4	Sechskantschraube	M20x110 DIN931-8.8	Hex. bolt	Vis 6 pans
8	980DV20P	4	Sicherungsmutter	VM20 DIN980-8	Lock nut	Ecrou frein
9	9006.39.20	4	Klemmplatte		Clamp plate	Plaque de serrage
10	980DV10N	8	Sicherungsmutter	VM10 DIN980-10	Lock nut	Ecrou frein
11	8413.63.00	2	Federhalter		Bracket	Support
12	960D161560M	4	Sechskantschraube	M16x1,5x60 DIN960-12.	Hex. bolt	Vis 6 pans
13	8405.00.18	4	Poly-Stop-Sechskantm	M16x1,5	Poly-Stop nut	Ecrou Poly-Stop
14	6329.00.01	2	Spindellager	LB-53	Spindle guide	Palier
15	8411.88.01	2	Distanzrohr		Spacer	Entretoise
16	933D20200P	2	Sechskantschraube	M20x200 DIN933-8.8	Hex. bolt	Vis 6 pans
17	8413.65.00	2	Federspanner	2 Fed.(springs/ressorts)	Tensioner	Tendeur
17a	8413.93.00	2	Federspanner	3 Fed.(springs/ressorts)	Tensioner	Tendeur
17a	8413.91.00	2	Federspanner	3 Fed.(springs/ressorts)	Tensioner	Tendeur
18	8404.01.31	4(6)	Zugfeder	CF-288	Tension spring	Ressort
18	8404.30.11	4(6)	Zugfeder	CF-314	Tension spring	Ressort
19	8413.64.01	1	Federaufhängung, links	2 Fed.(springs/ressorts)	Bracket	Support
19	8413.64.02	1	Federaufhängung, rech	2 Fed.(springs/ressorts)	Bracket	Support
19a	8413.92.01	1	Federaufhängung, links	3 Fed.(springs/ressorts)	Bracket	Support
19a	8413.92.02	1	Federaufhängung, rech	3 Fed.(springs/ressorts)	Bracket	Support
20	931D1245N	4	Sechskantschraube	M12x45 DIN931-10.9	Hex. bolt	Vis 6 pans
21	980DV12N	4	Sicherungsmutter	VM12 DIN980-10	Lock nut	Ecrou frein
22	8409.99.02	2	Steckstock		Pin	Axe
23	4716.35.00	2	Federsteckstock	BTB-4	R-clip	Goupille beta
24	8409.99.01	2	Steckstock		Pin	Axe
25	1481D636	2	Spannstift	6x36 DIN1481	Dowel pin	Goupille serrage
26	1498D253214	2	Buchse	EG 25/32x14 DIN1498	Bush	Douille
27	8413.66.01	1	Seitenarm, links	2,5 m	Side arm l.h.	Bras laterale gauche
27	8413.66.02	1	Seitenarm, rechts	2,5 m	Side arm r.h.	Bras laterale droit
27	8413.67.01	1	Seitenarm, links	3,0 m	Side arm l.h.	Bras laterale gauche
27	8413.67.02	1	Seitenarm, rechts	3,0 m	Side arm r.h.	Bras laterale droit

Ersatzteilliste

B

 Seitenblech, Walzen
 Side plate, rollers
 Tôle de laterale, rouleaux

PKE 250, 300 Br.7-8
PKE 400, 450 Br.8-9

Bild Ref. Fig.	Bestellnr. Part.-No. Référence	Stck Qty. Qte.	Bezeichnung	Technische Angaben Technical data Données techniques	Description	Désignation
27	8427.46.01	1	Seitenarm, links	3,5 - 4,5 m	Side arm l.h.	Bras laterale gauche
27	8427.46.02	1	Seitenarm, rechts	3,5 - 4,5 m	Side arm r.h.	Bras laterale droit
28-30	8404.28.07	2	FLANSCHLAGER KPL.	Ø40 mm	BEARING CPL.	PALIER CPL.
28	8405.00.23	2	Flanschlager		Bearing	Palier
29	71412DB81	2	Schmiernippel	BM8x1 DIN71412	Grease nippel	Graisseur
30	8404.28.06	2	Rillenkugellager		Ball bearing	Roulement à billes
31	933D1240N	8	Sechskantschraube	M12x40 DIN933-10.9	Hex. bolt	Vis 6 pans
31	931D1245N	8	Sechskantschraube	M12x45 DIN931-10.9	Hex. bolt	Vis 6 pans
31	980DV12NA	8	Sicherungsmutter	VM12 DIN980-10 verz.	Lock nut	Ecrou frein
32	8406.19.01	1	Stabpackerwalze	2,5m Ø440	Bar crumbler roller	Rouleau à barres
32	8406.19.02	1	Stabpackerwalze	3,0m Ø440	Bar crumbler roller	Rouleau à barres
32	8404.41.00	1	Stabpackerwalze	4,0m Ø440	Bar crumbler roller	Rouleau à barres
32	8413.90.03	1	Stabpackerwalze	4,5m Ø440	Bar crumbler roller	Rouleau à barres
33	8406.59.11	1	Zahnpackerwalze	UZW 250	Packer roller	Rouleau packer
33	8406.59.12	1	Zahnpackerwalze	UZW 300	Packer roller	Rouleau packer
33	8406.59.13	1	Zahnpackerwalze	UZW 400	Packer roller	Rouleau packer
33	8406.59.19	1	Zahnpackerwalze	UZW 450	Packer roller	Rouleau packer
33a	8406.60.02	1	Abstreifer	UZW 250	Scraper	Barre decrottoir
33a	8406.60.03	1	Abstreifer	UZW 300	Scraper	Barre decrottoir
33a	8406.60.04	1	Abstreifer	UZW 400	Scraper	Barre decrottoir
33a	8406.60.22	1	Abstreifer	UZW 450	Scraper	Barre decrottoir
33b	931D1255M	8	Sechskantschraube	M12x55 DIN931-12.9	Hex. bolt	Vis 6 pans
33b	931D1250P	8	Sechskantschraube	M12x50 DIN931-8.8	Hex. bolt	Vis 6 pans
33b	980DV12MA	8	Sicherungsmutter	VM12 DIN980-12 verz.	Lock nut	Ecrou frein
33b	980DV12PA	8	Sicherungsmutter	VM12 DIN980-8 verz.	Lock nut	Ecrou frein
33c	8432.00.34	2	Scheibe		Washer	Rondelle
34	6810.01.02	1	Zahnpackerwalze	GZW 250	Packer roller	Rouleau packer
34	6810.01.03	1	Zahnpackerwalze	GZW 300	Packer roller	Rouleau packer
34	6810.01.05	1	Zahnpackerwalze	GZW 400	Packer roller	Rouleau packer
34	6810.01.06	1	Zahnpackerwalze	GZW 450	Packer roller	Rouleau packer
34a	8406.53.02	1	Abstreifer	GZW 250	Scraper	Barre decrottoir
34a	8406.53.35	1	Abstreifer	GZW 300	Scraper	Barre decrottoir
34a	8406.53.04	1	Abstreifer	GZW 400	Scraper	Barre decrottoir
34a	8406.53.29	1	Abstreifer	GZW 450	Scraper	Barre decrottoir

Ersatzteilliste



B

Seitenblech, Walzen
Side plate, rollers
Tôle de laterale, rouleaux

PKE 250, 300 Br.7-8
PKE 400, 450 Br.8-9

Bild Ref. Fig.	Bestellnr. Part.-No. Référence	Stck Qty. Qte.	Bezeichnung	Technische Angaben Technical data Données techniques	Description	Désignation
35	931D1290N	8	Sechskantschraube	M12x90 DIN931-10.9	Hex.bolt	Vis 6 pans
35	980DV12NA	8	Sicherungsmutter	VM12 DIN980-10 verz.	Lock nut	Ecrou frein
35a	8434.29.09	2	Scheibe		Washer	Rondelle
36	8406.25.06	2	Distanzplatte		Spacer plate	Entretoise
37	8405.00.27		Abstreiferblech		Scraper plate	Tôle de décrottoir
38	603D1230PA		Flachrundschrabe	M12x30 DIN603-8.8 verz	Bolt	Vis
39	7349D13A		Scheibe	13 DIN7349 verz.	Washer	Rondelle
40	934D12PA		Sechskantmutter	M12 DIN934-8 verz.	Hex. nut	Ecrou 6 pans
41	4716.37.00	1	Typenschild	SX-4	ID-plate	ID-plaque
41	1476D410	2	Halbrundkerbnagel	4x10 DIN1476	Rivet	Rivet
42	933D1235N	2	Sechskantschraube	M12x35 DIN933-10.9	Hex. bolt	Vis 6 pans
44-46	8432.23.01	2	FLANSCHLAGER KPL.	Ø40 mm	BEARING CPL.	PALIER CPL.
44	8432.23.02	2	Flanschlager		Bearing	Palier
45	71412DB81	2	Schmiernippel	BM8x1 DIN71412	Grease nippel	Graisneur
46	8432.23.03	2	Spannlager	GNVE 40KRRBCC	Bearing	Roulement
44-46	8434.29.01	2	FLANSCHLAGER KPL.	Ø55 mm	BEARING CPL.	PALIER CPL.
44	8434.29.02	2	Flanschlager		Bearing	Palier
45	71412DB81	2	Schmiernippel	BM8x1 DIN71412	Grease nippel	Graisneur
46	8434.29.03	2	Spannlager	PDFN 160-55-26	Bearing	Roulement

Ersatzteilliste



C

Wechselradgetriebe, Antrieb
 Gearbox, drive
 Boîte de vitesse, entraînement.

PKE 250,300 Br.8, PKE 400,450 Br.9

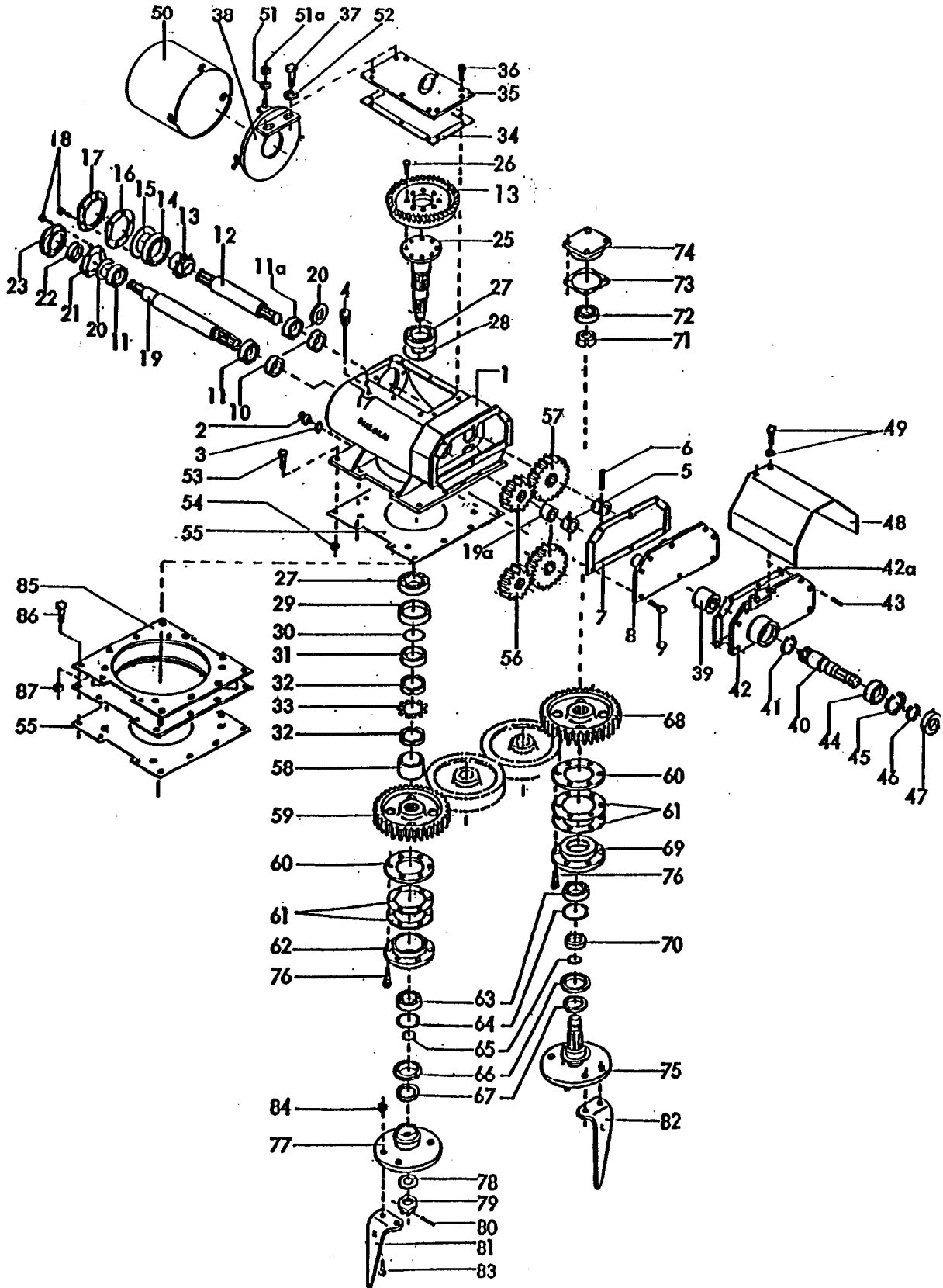

Ersatzteilliste



C

Wechselradgetriebe, Antrieb
Gearbox, drive
Boîtier de vitesse, entraînement

PKE 250, 300 Br.8, PKE 400, 450 Br.9

Bild Ref. Fig.	Bestellnr. Part.-No. Référence	Stck Qty. Qte.	Bezeichnung	Technische Angaben Technical data Données techniques	Description	Désignation
1-38	8427.42.01	1	GETRIEBE	PKE 300,400	GEARBOX CPL.	BOITIER DE VITESSE
1-38	8427.42.03	1	GETRIEBE HOCHGEL.	PKE 300,400	GEARBOX CPL.	BOITIER DE VITESSE
1-38	8427.42.02	1	GETRIEBE	PKE 250,350,450	GEARBOX CPL.	BOITIER DE VITESSE
1-38	8427.42.04	1	GETRIEBE HOCHGEL.	PKE 250,350,450	GEARBOX CPL.	BOITIER DE VITESSE
1-38	8427.41.05	1	GETRIEBE+DURCHTR	1 3/4" PKE 300,400	GEARBOX CPL.	BOITIER DE VITESSE
1-38	8427.41.09	1	GETR. HOCH.+DURC	1 3/4" PKE 300,400	GEARBOX CPL.	BOITIER DE VITESSE
1-38	8427.41.07	1	GETRIEBE+DURCHTR	1 3/8" PKE 300,400	GEARBOX CPL.	BOITIER DE VITESSE
1-38	8427.41.11	1	GETRIEBE+DURCHTR	1 3/8" PKE 300,400	GEARBOX CPL.	BOITIER DE VITESSE
1-38	8427.41.04	1	GETRIEBE+DURCHTR	1 3/4" PKE 250,350,450	GEARBOX CPL.	BOITIER DE VITESSE
1-38	8427.41.08	1	GETR. HOCH.+DURC	1 3/4" PKE 250,350,450	GEARBOX CPL.	BOITIER DE VITESSE
1-38	8427.41.06	1	GETRIEBE+DURCHTR	1 3/8" PKE 250,350,450	GEARBOX CPL.	BOITIER DE VITESSE
1-38	8427.41.10	1	GETR. HOCH.+DURC	1 3/8" PKE 250,350,450	GEARBOX CPL.	BOITIER DE VITESSE
1	8413.02.01	1	Getriebegehäuse	PKE 250, 350, 450	Housing	Carter
1	8413.02.02	1	Getriebegehäuse	PKE 300, 400	Housing	Carter
2	7604DA1815R	1	Verschlußschraube	AM18x1,5 DIN7604-5.6	Hexagon head plug	Bouchon fileté
3	7603DA18221	1	Dichtring	A18x22x1,5 DIN7603-C	Seal ring	Joint
4	8413.01.10	1	Be-und Entlüftungsfilter		Breather	Reniflard avec jauge
5	8416.01.05	2	Buchse		Bush	Douille
6	1481D650	2	Spannstift	6x50 DIN1481	Dowel pin	Goupille serrage
7	8413.01.07	1	Getriebedichtung		Gasket	Joint de boîte de vitesse
8	8427.01.02	1	Getriebedeckel rechts		Lid	Couvercle de carter
8	8427.01.03	1	Getriebedeckel links		Lid	Couvercle de carter
9	933D1025N	6	Sechskantschraube	M10x25 DIN933-10.9	Hex. bolt	Vis 6 pans
10	8411.08.14	2	Distanzbuchse		Spacer	Bague entretoise
11	720D30210	3	Kegelrollenlager	30210 DIN720	Taper roller bearing	Roulement à rouleaux
12	8413.01.03	1	Ritzelwelle		Pinion shaft	Arbre intermediaire
13	8413.01.15	1	Kegeltrieb kpl.	Z 13/38	Bevel gear set	Paire de pignons conique
14	720D30214	1	Kegelrollenlager	30214 DIN720	Taper roller bearing	Roulement à rouleaux
15	8404.46.05	1	Satz Paßscheiben	E1 110x125	Gauge washer kit	Jeu de cale d'ajustage
16	8411.08.04	1	Gehäusedichtung	Ø125,5xØ165	Gasket	Joint de carter
17	8411.08.09	1	Verschlußdeckel	NW-21	End lid	Couvercle de fermé
18	933D1035NVP	10	Verbus-Plus Schraube	M10x35 DIN933-10.9	Verbus-Plus bolt	Boulon hex. indesserable
19	8427.41.01	1	Antriebswelle		Input shaft	Arbre d'entree
19a	8427.02.01	1	Zwischenhülse		Sleeve	Douille
20	8404.46.04	2	Satz Paßscheiben	E1 80x90	Gauge washer kit	Jeu de cale d'ajustage
21	8411.08.03	1	Gehäusedichtung	Ø90,5xØ130	Gasket	Joint de carter
22	8404.22.02	1	Wellendichtung	50x65x8 B1 SL	Shaft sealing ring	Joint de arbre

Ersatzteilliste



C

Wechselradgetriebe, Antrieb
Gearbox, drive
Boîtier de vitesse, entraînement

PKE 250, 300 Br.8, PKE 400, 450 Br.9

Bild Ref. Fig.	Bestellnr. Part.-No. Référence	Stck Qty. Qte.	Bezeichnung	Technische Angaben Technical data Données techniques	Description	Désignation
23	8411.08.10	1	Verschlusskappe	NW-22	End lid	Couvercle de fermé
25	8413.01.01	1	Getriebewelle		Shaft	Arbre
25	8427.02.06	1	Getriebewelle für hoch.		Shaft	Arbre
26	933D1235MVP	8	Verbus-Plus Schraube	M12x35 DIN933-12.9	Verbus-Plus bolt	Boulon hex. indesserable
27	720D33013	2	Kegelrollenlager	33013 DIN720	Taper roller bearing	Roulement à rouleaux
28	8404.46.06	1	Satz Paßscheiben	E1 90x100	Gauge washer kit	Jeu de cale d'ajustage
29	8404.21.04	1	Wellendichtring	80/105/13 B2	Shaft sealing ring	Joint de arbre
30	8404.26.08	1	O-Ring	65x1,8	O-seal	Joint torique
31	8413.01.06	1	Distanzbuchse		Spacer	Bague entretoise
32	981DKM13	2	Nutmutter	KM13 DIN981	Key nut	Ecrou à garges
33	5406DMB13	1	Sicherungsblech	MB13 DIN5406	Lock plate	Toile de securite
34	8413.01.08	1	Gehäusedichtung		Gasket	Joint de carter
35	8413.05.00	1	Gehäusedeckel		Cover	Couvercle
36	933D1020N	2	Sechskantschraube	M10x20 DIN933-10.9	Hex. bolt	Vis 6 pans
36	933D1020NVP	6	Verbus-Plus Schraube	M10x20 DIN933-10.9	Verbus-Plus bolt	Boulon hex. indesserable
37	933D1035N	2	Sechskantschraube	M10x35 DIN933-10.9	Hex. bolt	Vis 6 pans
38	8418.27.01	1	Schutzscheibe, rechts	3,0m + 4,0m	Safety washer	Rondelle de protection
38	8418.27.02	1	Schutzscheibe, links	2,5m + 3,5m + 4,5m	Safety washer	Rondelle de protection
7,39-49	8427.41.13	1	DURCHTR.-NACHRÜS	1 3/4" PKE 300, 400	PTO THROUGH DRI	PRISE DE FORCE ARR
7,39-49	8427.41.15	1	DURCHTR.-NACHRÜS	1 3/8" PKE 300, 400	PTO THROUGH DRI	PRISE DE FORCE ARR
7,39-49	8427.41.12	1	DURCHTR.-NACHRÜS	1 3/4" PKE 250, 350, 4	PTO THROUGH DRI	PRISE DE FORCE ARR
7,39-49	8427.41.14	1	DURCHTR.-NACHRÜS	1 3/8" PKE 250, 350, 4	PTO THROUGH DRI	PRISE DE FORCE ARR
7	8413.01.07	1	Getriebedichtung		Gasket	Joint de boite de vitesse
39	8411.37.03	1	Buchse		Bush	Douille
40	8427.41.02	1	Zapfwellenstummel	1 3/4"	Shaft	Arbre
40	8427.41.03	1	Zapfwellenstummel	1 3/8"	Shaft	Arbre
41	471D502	1	Sicherungsring	50x2 DIN471	Circlip	Circlip
42	8413.23.04	1	Getriebedeckel rechts .		Lid	Couvercle de carter
42	8413.23.05	1	Getriebedeckel links .		Lid	Couvercle de carter
42a	8413.01.14	1	Getriebedichtung	2 mm	Gasket	Joint de boite de vitesse
43	6325D8m624	2	Zylinderstift	8-M6x24 DIN6325	Cylindrical dovel	Goupille fendue
44	625D6209	1	Rillenkugellager	6209 DIN625	Ball bearing	Roulement à billes
45	472D853	1	Sicherungsring	85x3 DIN472	Circlip	Circlip
46	471D451,75	1	Sicherungsring	45x1,75 DIN471	Circlip	Circlip
47	8404.21.05	1	Wellendichtring	45x85x13 B2	Shaft sealing ring	Joint de arbre
48	8406.48.05	1	Zapfwellenschutz		PTO shield	Dispositif de protection
49	933D825P	2	Sechskantschraube	M8x25 DIN933-8.8	Hex. bolt	Vis 6 pans

Ersatzteilliste



C

Wechselradgetriebe, Antrieb
Gearbox, drive
Boîtier de vitesse, entraînement

PKE 250, 300 Br.8, PKE 400, 450 Br.9

Bild Ref. Fig.	Bestellnr. Part.-No. Référence	Stck Qty. Qte.	Bezeichnung	Technische Angaben Technical data Données techniques	Description	Désignation
49	127DA8A	2	Federring	A8 DIN127 verz.	Springwasher	Rondelle grower
50	8418.00.06	1	Zapfwellenschutz		PTO shield	Dispositif de protection
51	126D9	3	Scheibe	9 DIN126	Washer	Rondelle
51a	980DV8P	3	Sicherungsmutter	VM8 DIN980-8	Lock nut	Ecrou frein
52	126D11A	2	Scheibe	11 DIN126 verz.	Washer	Rondelle
53	931D1245M	6	Sechskantschraube	M12x45 DIN931-12.9	Hex. bolt	Vis 6 pans
54	980DV12M	10	Sicherungsmutter	VM12 DIN980-12	Lock nut	Ecrou frein
55	8411.00.21	1(2)	Dichtung	1 mm	Seal	Joint
56	8413.00.01	1	Wechselrad	Z 12	Change gear	Pignon interchangeable
57	8413.00.02	1	Wechselrad	Z 23	Change gear	Pignon interchangeable
56	8413.00.38	1	Wechselrad	Z 13	Change gear	Pignon interchangeable
57	8413.00.39	1	Wechselrad	Z 22	Change gear	Pignon interchangeable
56	8413.00.03	1	Wechselrad	Z 14	Change gear	Pignon interchangeable
57	8413.00.04	1	Wechselrad	Z 21	Change gear	Pignon interchangeable
56	8413.00.05	1	Wechselrad	Z 15	Change gear	Pignon interchangeable
57	8413.00.06	1	Wechselrad	Z 20	Change gear	Pignon interchangeable
56	8413.00.07	1	Wechselrad	Z 16	Change gear	Pignon interchangeable
57	8413.00.08	1	Wechselrad	Z 19	Change gear	Pignon interchangeable
56	8413.00.09	1	Wechselrad	Z 17	Change gear	Pignon interchangeable
57	8413.00.10	1	Wechselrad	Z 18	Change gear	Pignon interchangeable
58	8413.00.35	1	Distanzrohr		Spacer	Entretoise
58	8427.00.01	1	Distanzrohr		Spacer	Entretoise
59	8413.00.11	1	Zahnrad	Z 49	Central gear	Roue denteé central
60	8413.00.22		Bodenverstärkung		Reinforcement	Renforcement
61	8413.00.23		Lagerflanschdichtung		Seal	Joint
62	8413.00.21	1	Lagerflansch Mitte		Bearing flange	Bride support
63	625D6211		Rillenkugellager	6211 DIN625	Ball bearing	Roulement à billes
64	472D1003		Sicherungsring	100x3 DIN472	Circlip	Circlip
65	8404.26.06		O-Ring	55x2	O-seal	Joint torique
66	8433.00.13		Wellendichtring	70/100/10	Shaft sealing ring	Joint de arbre
67	8404.27.00		Gamma-Ring	RB-70X90X5,5	Gamma ring	Joint gamma
68	8413.00.15		Zahnrad	Z 49	Gear	Rou dentreé
69	8413.00.20		Lagerflansch		Bearing flange	Bride support
70	8413.00.18		Lauftring		Ring	Baque
71	8413.00.32		Nutmutter	PM 50x1,5 SSN 546	Key nut	Ecrou à garges
72	625D62082RS		Rillenkugellager	6208 2RS DIN625	Ball bearing	Roulement à billes
73	8427.12.00		Lagerdeckeldichtung		Seal	Joint

Ersatzteilliste



C

Wechselradgetriebe, Antrieb
Gearbox, drive
Boîtier de vitesse, entraînement

PKE 250, 300 Br.8, PKE 400, 450 Br.9

Bild Ref. Fig.	Bestellnr. Part.-No. Référence	Stck Qty. Qte.	Bezeichnung	Technische Angaben Technical data Données techniques	Description	Désignation
74	8427.11.00		Lagerdeckel		Bearing cover	Couvercle
75	8413.00.17		Welle+Messerhalter, lin		Shaft with kniftein hol	Arbre porte couteau
76	8426.13.07		Verbuss-Ripp-Sechskan	M12x30-100	Verbuss-Ripp bolt	Boulon hex. indesserable
77	8413.00.14	1	Messerhalter		Holder	Porte bêche
78	126D36	1	Scheibe		Washer	Rondelle
79	937D3615P	1	Kronenmutter	M36x1,5 DIN937-8	Castellated nut	Ecrou crênelé
80	1481D650	1	Spannstift	6x50 DIN1481	Dowel pin	Goupille serrage
81	8404.50.01		Kreismesser, rechts	KG-30	Knife tine	Couteau
81	8404.50.02		Kreismesser, links	KG-30L	Knife tine	Couteau
82	8411.62.03		RABID-Kreismesser,	KG-30 Z	Knife tine	Couteau
82	8411.62.04		RABID-Kreismesser, l	KG-30LZ	Knife tine	Couteau
83	960D161560M		Sechskantschraube	M16x1,5x60 DIN960-12.	Hex. bolt	Vis 6 pans
84	8405.00.18		Poly-Stop-Sechskantm	M16x1,5	Poly-Stop nut	Ecrou Poly-Stop
85	8427.15.00	1	Zwischenring		Ring	Baque
86	931D1245M	12	Sechskantschraube	M12x45 DIN931-12.9	Hex. bolt	Vis 6 pans
87	980DV12M	12	Sicherungsmutter	VM12 DIN980-12	Lock nut	Ecrou frein
.						
.						
.						
.						
.						
.						
.						
.						
.						
.						
.						
.						
.						
.						
.						
.						
.						
.						
.						
.						
.						
.						
.						
.						
.						
.						

Ersatzteilliste



D

Schaltgetriebe
Lever gearbox
Boîtier à selecteur

PKE, SKE

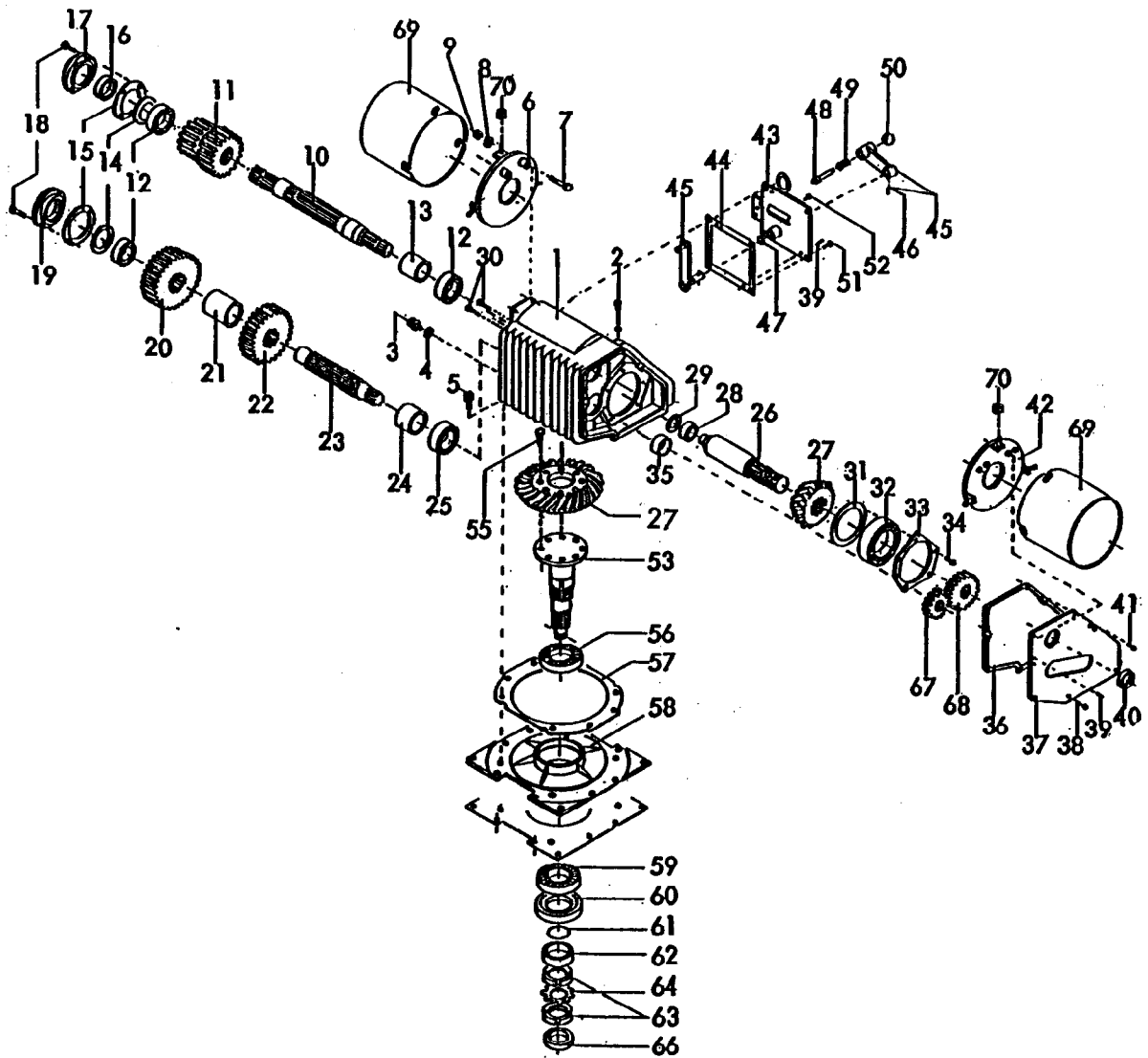

Ersatzteilliste



D

Schaltgetriebe
Lever gearbox
Boîtier à selecteur

PKE, SKE

Bild Ref. Fig.	Bestellnr. Part.-No. Référence	Stck Qty. Qte.	Bezeichnung	Technische Angaben Technical data Données techniques	Description	Désignation
1-66	8427.04.02	1	SCHALTGETRIEBE	1 3/8" PKE 300,400	LEVER GEARBOX	BOITIER A SELECTEU
1-66	8427.04.03	1	SCHALTGETRIEBE	1 3/8" PKE 250,350,45	LEVER GEARBOX	BOITIER A SELECTEU
1-66	8427.04.05	1	SCHALTGETRIEBE	1 3/4" PKE 300,400	LEVER GEARBOX	BOITIER A SELECTEU
1-66	8427.04.06	1	SCHALTGETRIEBE	1 3/4" PKE 250,350,45	LEVER GEARBOX	BOITIER A SELECTEU
1-64	8427.04.01	1	SCHALTGETRIEBE	1 3/8" SKE 300,400,50	LEVER GEARBOX	BOITIER A SELECTEU
1-64	8427.04.38	1	SCHALTGETRIEBE	1 3/8" SKE 450	LEVER GEARBOX	BOITIER A SELECTEU
1-64	8427.04.04	1	SCHALTGETRIEBE	1 3/4" SKE 300,400,50	LEVER GEARBOX	BOITIER A SELECTEU
1-64	8427.04.39	1	SCHALTGETRIEBE	1 3/4" SKE 450	LEVER GEARBOX	BOITIER A SELECTEU
1	8427.03.01	1	Getriebegehäuse	3,0m+4,0m+5,0m+6,0m	Housing	Carter
1	8427.03.02	1	Getriebegehäuse	2,5m+3,5m+4,5m	Housing	Carter
2	8412.61.27	1	Meßstab		Dipstick	Jauge d'huile
3	7604DA1615R	1	Verschlußschraube	AM16x1,5 DIN7604-5.6	Hexagon head plug	Bouchon fileté
4	7603DA16201	1	Dichtring	A16x20x1,5 DIN7603-C	Seal ring	Joint
5	933D1230NVP	4	Verbus-Plus Schraube	M12X30 DIN933-10.9	Verbus-Plus bolt	Boulon hex. indesserable
6	8418.27.03	1	Schutzscheibe		Safety washer	Rondelle de protection
7	931D850P	2	Sechskantschraube	M8x50 DIN931-8.8	Hex. bolt	Vis 6 pans
9	980DV8P	2	Sicherungsmutter	VM8 DIN980-8	Lock nut	Ecrou frein
10	8427.04.11	1	Durchtriebswelle	1 3/8"	Input shaft	Arbre d'entree
10	8427.04.12	1	Durchtriebswelle	1 3/4"	Input shaft	Arbre d'entree
11	8427.04.37	1	Schaltrad	Z 17/18	Gear	Roue commande
12	720D32210	3	Kegelrollenlager	32210 DIN720	Taper roller bearing	Roulement à rouleaux
13	8427.04.27	1	Sicherungshülse		Sleeve	Douille
14	8404.46.04	2	Satz Paßscheiben	E1 80x90	Gauge washer kit	Jeu de cale d'ajustage
15	8411.08.03	2	Gehäusedichtung	Ø90,5xØ130	Gasket	Joint de carter
16	8404.22.02	1	Wellendichtung	50x65x8 B1 SL	Shaft sealing ring	Joint de arbre
17	8411.08.10	1	Verschlußkappe	NW-22	End lid	Couvercle de fermé
19	8427.04.09	1	Deckel		Lid	Couvercle
20	8427.04.35	1	Schaltrad	Z 25	Gear	Roue commande
21	8427.04.28	1	Distanzrohr		Spacer	Entretoise
22	8427.04.36	1	Schaltrad	Z 24	Gear	Roue commande
23	8427.04.10	1	Zwischenwelle		Interm. Shaft	Arbre
24	8427.04.29	1	Abstandsrohr		Pipe	Tube
25	720D32211	1	Kegelrollenlager	32211 DIN720	Taper roller bearing	Roulement à rouleaux
26	8427.04.13	1	Ritzelwelle		Pinion shaft	Arbre intermédiaire
27	8427.04.23	1	Kegelrad	Z 14	Bevel gear	Pignon conique
28	720D32007X	1	Kegelrollenlager	32007X DIN720	Taper roller bearing	Roulement à rouleaux
29	8404.46.08	1	Satz Paßscheiben	E1 52x62	Gauge washer kit	Jeu de cale d'ajustage
30	912D68P	2	Zylinderschraube	M6x8 DIN912-8.8	Spline screw	Vis cylindrique

Ersatzteilliste



D

Schaltgetriebe
Lever gearbox
Boîtier à selecteur

PKE, SKE

Bild Ref. Fig.	Bestellnr. Part.-No. Référence	Stck Qty. Qte.	Bezeichnung	Technische Angaben Technical data Données techniques	Description	Désignation
31	8404.46.07	1	Satz Paßscheiben	E1 140x160	Gauge washer kit	Jeu de cale d'ajustage
32	720D30218	1	Kegelrollenlager	30218 DIN720	Taper roller bearing	Roulement à rouleaux
33	8427.04.25	1	Druckplatte	3,0m+4,0m+5,0m+6,0m	Thrust plate r.h.	Rond. de butee droit
33	8427.04.40	1	Druckplatte	2,5m+3,5m+4,5m	Thrust plate l.h.	Rond. de butee gauche
34	7991D1040N	6	Senkschraube	M10x40 DIN7991-10.9	C sunk screw	Vis tête noyee
35	8427.04.30	1	Distanzbuchse		Spacer	Bague entretoise
36	8427.04.31	1	Getriebedichtung	2 mm	Gasket	Joint de boite de vitesse
37	8427.05.01	1	Getriebedeckel	3,0m+4,0m+5,0m+6,0m	Lid	Couvercle de carter
37	8427.05.02	1	Getriebedeckel	2,5m+3,5m+4,5m	Lid	Couvercle de carter
38	933D1020N	5	Sechskantschraube	M10x20 DIN933-10.9	Hex. bolt	Vis 6 pans
39	1472D820	4	Passkerbstift	8x20 DIN1472	Fixing pin	Goupille de centrage
40	3760D45608A	1	Wellendichtring	45x60x8 AS DIN3760	Shaft sealing ring	Joint de arbre
41	933D1035N	2	Sechskantschraube	M10x35 DIN933-10.9	Hex. bolt	Vis 6 pans
42	8412.69.00	1	Schutzscheibe, hinten		Safety washer rear	Rond. de protec. Arrière
43	8427.08.01	1	Deckel	3,0m+4,0m+5,0m+6,0m	Lid	Couvercle
43	8427.08.02	1	Deckel	2,5m+3,5m+4,5m	Lid	Couvercle
44	8427.04.32	1	Deckeldichtung	2 mm	Packing	Joint de couvercle
45	8427.07.01	1	Schaltgestänge kpl.	3,0m+4,0m+5,0m+6,0m	Shift rod cpl.	Barre embrayage cpl.
45	8427.07.02	1	Schaltgestänge kpl.	2,5m+3,5m+4,5m	Shift rod cpl.	Barre embrayage cpl.
46	1D640	1	Kegelstift	6x40 DIN1	Collet pin	Goupille cone
47	8132.04.02	1	O-Ring	OR 16x2,5	O-seal	Joint torique
48	8412.61.16	1	Druckbolzen		Pin	Axe
49	8412.61.17	1	Druckfeder	DF-129	Compression spring	Ressort
50	319DC4012	1	Kugelknopf	C40xM12 DIN319-FS	Ball joint	Joint à rotule
51	933D1025NVP	4	Verbus-Plus Schraube	M10x25 DIN933-10.9	Verbus-Plus bolt	Boulon hex. indesserable
52	8404.47.00	1	Be-und Entlüftungsfilter		Breather	Reniflard
53	8427.04.08	1	Getriebewelle	PKE	Shaft	Arbre
53	8427.04.07	1	Getriebewelle	SKE	Shaft	Arbre
54	8427.04.24	1	Tellerrad	Z 29		
55	933D1240MVP	8	Verbus-Plus Schraube	M12x40 DIN933-12.9	Verbus-Plus bolt	Boulon hex. indesserable
56	720D32018X	1	Kegelrollenlager	32018X DIN720	Taper roller bearing	Roulement à rouleaux
57	8411.08.11	1	Getriebedichtung	Ø326xØ410	Gasket	Joint de boite de vitesse
57	8411.08.16	1	Getriebedichtung	Ø326xØ410	Gasket	Joint de boite de vitesse
58	8427.04.26	1	Lagerplatte		Bearing plate	Plaque palier
59	720D32014X	1	Kegelrollenlager	32014X DIN720	Taper roller bearing	Roulement à rouleaux
60	8404.21.10	1	Wellendichtring	85/115/13 B2	Shaft sealing ring	Joint de arbre
61	8404.26.03	1	O-Ring	70x2	O-seal	Joint torique
62	8427.04.34	1	Distanzbuchse		Spacer	Bague entretoise

Ersatzteilliste



D

Schaltgetriebe
Lever gearbox
Boîtier à selecteur

PKE, SKE

Bild Ref. Fig.	Bestellnr. Part.-No. Référence	Stck Qty. Qte.	Bezeichnung	Technische Angaben Technical data Données techniques	Description	Désignation
63	981DKM14	2	Nutmutter	KM14 DIN981	Key nut	Ecrou à garges
64	5406DMB14	1	Sicherungsblech	MB14 DIN5406	Lock plate	Toile de securite
66	8427.04.33	1	Abstandsrohr		Pipe	Tube
67	8427.04.18	1	Wechselrad	Z 17	Change gear	Pignon interchangeable
67	8427.04.20	1	Wechselrad	Z 16	Change gear	Pignon interchangeable
68	8427.04.19	1	Wechselrad	Z 21	Change gear	Pignon interchangeable
67	8427.04.22	1	Wechselrad	Z 18	Change gear	Pignon interchangeable
68	8427.04.21	1	Wechselrad	Z 19	Change gear	Pignon interchangeable
69	8418.00.06	2	Zapfwellenschutz		PTO shield	Dispositif de protection
70	8418.00.09	6	Poly-Stop-Scheibenmu	M8-8	Poly-Stop nut	Ecrou Poly-Stop

Ersatzteilliste



E

Dreipunktgestänge für Anbaugeräte

Rear hitch mechan.

Attelage 3 points mechan.

MKE, PKE, Kompaktegge, PZ

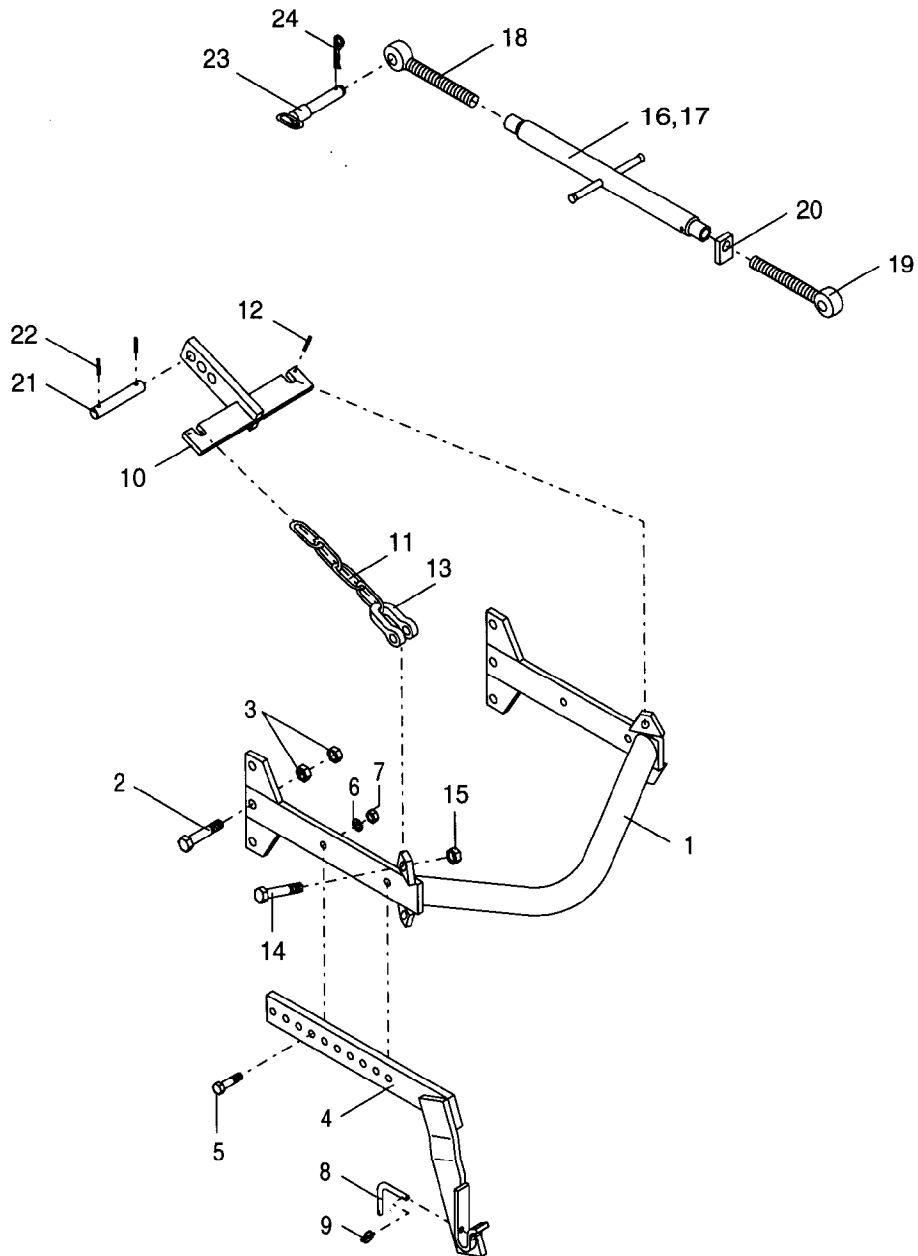

Ersatzteilliste

E

 Dreipunktgestänge mechanisch
 Rear hitch mechan.
 Attelage 3 points mechan.

MKE, PKE

Bild Ref. Fig.	Bestellnr. Part.-No. Référence	Stck Qty. Qte.	Bezeichnung	Technische Angaben Technical data Données techniques	Description	Désignation
1	8409.40.00	1	Grundrahmen		Frame	Bâti
2	931D2080P	2	Sechskantschraube	M20x80 DIN931-8.8	Hex. bolt	Vis 6 pans
3	934D20P	4	Sechskantmutter	M20 DIN934-8	Hex. nut	Ecrou 6 pans
4	8405.25.01	1	Anbauarm, rechts	Kat.2	Arm r.h.	Bras droit
4	8405.25.02	1	Anbauarm, links	Kat.2	Arm l.h.	Bras gauche
4	8405.45.01	1	Anbauarm, rechts	Kat.3 kurz (short, court)	Arm r.h.	Bras droit
4	8405.45.02	1	Anbauarm, links	Kat.3 kurz (short, court)	Arm l.h.	Bras gauche
4	8405.46.01	1	Anbauarm, rechts	Kat.3	Arm r.h.	Bras droit
4	8405.46.02	1	Anbauarm, links	Kat.3	Arm l.h.	Bras gauche
5	931D1655N	4	Sechskantschraube	M16x55 DIN931-10.9	Hex. bolt	Vis 6 pans
6	127DB16A	4	Federring	B16 DIN127 verz.	Springwasher	Rondelle grower
7	934D16PA	4	Sechskantmutter	M16 DIN934-8 verz.	Hex. nut	Ecrou 6 pans
8	8405.12.08	2	Griff	TB-12x70	Handle	Broche
9	8405.12.09	2	Klappstecker	STB-4,5x340	Linch-pin	Goupille auto.
10	8405.40.00	1	Verstellstück		Adjuster	Piecc de réglage
11	763D0,656K13	2	Kette	0,656m-13 DIN763	Chain	Chaîne
12	1481D636	2	Spannstift	6x36 DIN1481	Dowel pin	Goupille serrage
13	82101DF1-1,6	2	Bügel	F1-1,6 DIN82101	Fastener	Support
14	931D2075P	2	Sechskantschraube	M20x75 DIN931-8.8	Hex. bolt	Vis 6 pans
15	936D20P	2	Sechskantmutter	M20 DIN936-8	Hex. nut	Ecrou 6 pans
16-20	8411.34.00	1	SPANNSCHLOSS MO		TURNBUCKLE CPL.	TIRANT CPL.
17-20	8409.36.00	1	SPANNSCHLOSS MO		TURNBUCKLE CPL.	TIRANT CPL.
16	8411.34.01	1	Spannschloßmutter	LPM-27x600	Turnbuckle nut	Ecrou tendeur
17	8409.36.01	1	Spannschloßmutter	LPM-27x800	Turnbuckle nut	Ecrou tendeur
18	6329.06.03	1	Ösenshraube	M27x240 L	Eyebolt l.h.	Piton gauche
19	6329.06.04	1	Ösenshraube	M27x240	Eyebolt	Piton
20	4722.20.03	1	Kontermutter rechts ver		Counternut	Contre-écrou
21	8413.35.01	1	Turmbolzen verzinkt		Pin	Axe
22	1481D636	2	Spannstift	6x36 DIN1481	Dowel pin	Goupille serrage
23	8423.73.00	1	OL-Stock	Kat.2	Top link pin	Axe 3 points
24	4716.35.00	1	Federsteckstock	BTB-4	R-clip	Goupille beta

Ersatzteilliste



F

Hydr. Dreipunktgestänge
Rear hitch hydr.
Attelage hydr.

DRILL-LIFT

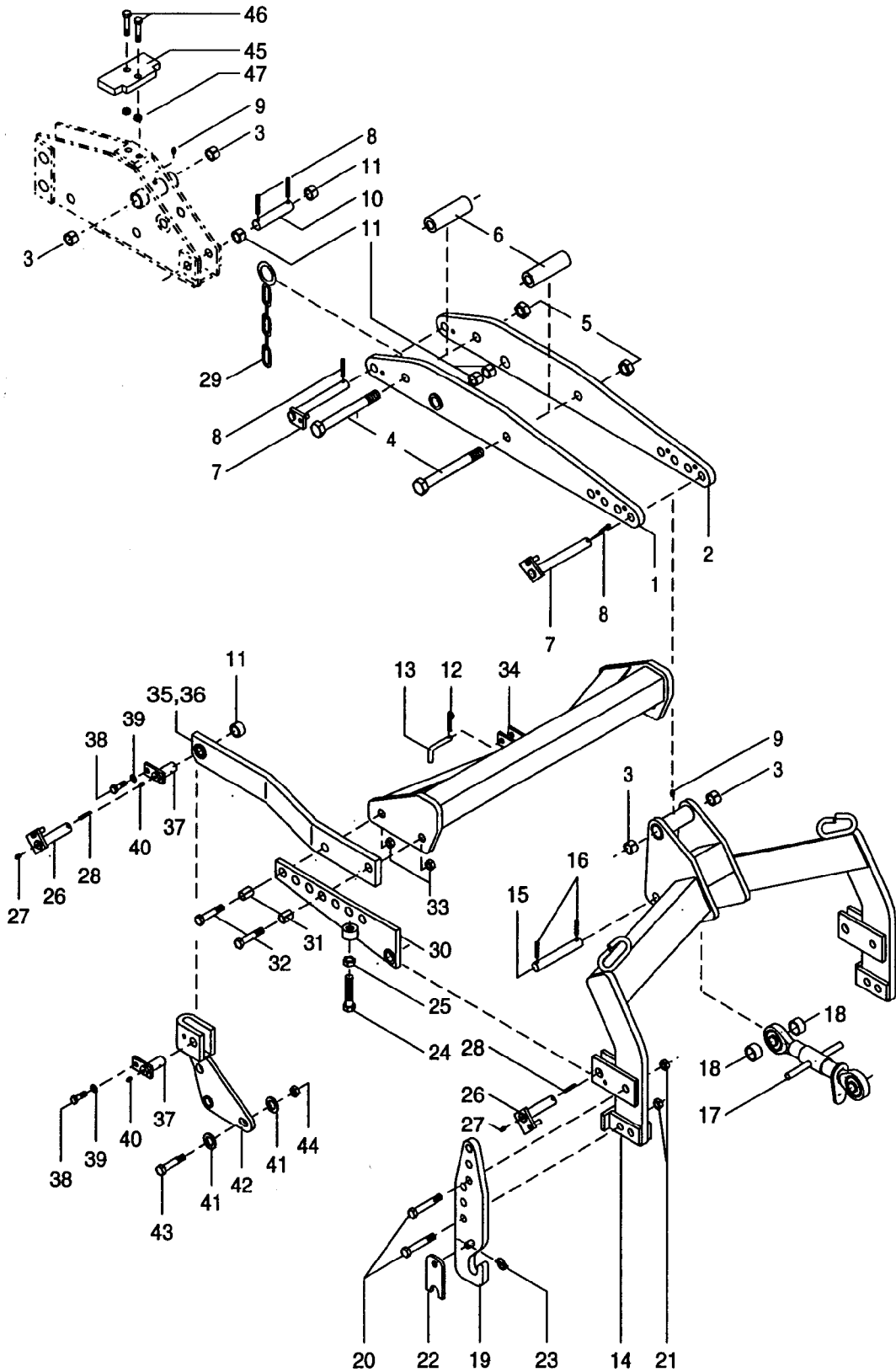

Ersatzteilliste



F

 Hydr. Dreipunktgestänge
 Rear hitch hydr.
 Attelage hydr.

Drill-Lift

Bild Ref. Fig.	Bestellnr. Part.-No. Référence	Stck Qty. Qte.	Bezeichnung	Technische Angaben Technical data Données techniques	Description	Désignation
	7606.07.03	1	DRILL-LIFT	BIS 3,0 M	DRILL-LIFT	DRILL-LIFT
	7606.14.01	1	DRILL-LIFT	Type 1	DRILL-LIFT	DRILL-LIFT
	7606.14.02	1	DRILL-LIFT	Type 2	DRILL-LIFT	DRILL-LIFT
1	7606.10.02	1	Hubarm, links		Lift arm l.h.	Bras interm. gauche
2	7606.10.01	1	Hubarm, rechts		Lift arm r.h.	Bras interm. droit
3	1498D253228	4	Buchse	EG 25/32x28 DIN1498	Bush	Douille
4	931D24200P	2	Sechskantschraube	M24x200 DIN931-8.8	Hex. bolt	Vis 6 pans
5	980DV24P	2	Sicherungsmutter	VM24 DIN980-8	Lock nut	Ecrou frein
6	7606.14.03	2	Distanzrohr		Spacer	Entretoise
7	8405.58.00	2	Hubbolzen verzinkt		Pin	Axe
8	1481D840A	4	Spannstift	8x40 DIN1481 verz.	Dowel pin	Goupille serrage
9	4716.38.00	2	Schmiernippel	H1 8x1 KX-1	Grease nippel	Graisseur
10	8413.35.01	1	Turmbolzen verzinkt		Pin	Axe
11	1498D253220	2-4	Buchse	EG 25/32x20 DIN1498	Bush	Douille
12	4716.35.00	1	Federsteckstock	BTB-4	R-clip	Goupille beta
13	6241.29.02	1	Steckstock	TB-12x50	Pin	Axe
14	7606.12.01	1	Hubturm		Lift headstock	Potence de relevage
15	7520.10.01	1	Lagerbolzen		Shaft	Axe
16	1481D840A	2	Spannstift	8x40 DIN1481 verz.	Dowel pin	Goupille serrage
17	9108.78.01	1	Oberlenker	280-335	Top link	Bras supp.
18	7606.14.04	2	Buchse		Bush	Douille
19	7606.11.02	1	Anlenkung, links	Kat. 2	Link arm l.h.	Bras réglable gau.
19	7606.11.01	1	Anlenkung, rechts	Kat. 2	Link arm r.h.	Bras réglable droit
19	7606.11.04	1	Anlenkung, links	Kat. 3	Link arm l.h.	Bras réglable gau.
19	7606.11.03	1	Anlenkung, rechts	Kat. 3	Link arm r.h.	Bras réglable droit
20	960D201590N	4	Sechskantschraube	M20x1,5x90 DIN960-10.	Hex. bolt	Vis 6 pans
21	980DV2015N	4	Sicherungsmutter	VM20x1,5 DIN980-10	Lock nut	Ecrou frein
22	6336.72.01	2	Riegel	Kat. 2	Latch Cat.2	Verrou Cat.2
22	6336.72.02	2	Riegel	Kat. 3	Latch Cat.3	Verrou Cat.3
23	8405.12.09	2	Klappstecker	STB-4,5x340	Linch-pin	Goupille auto.
24	933D20100P	2	Sechskantschraube	M20x100 DIN933-8.8	Hex. bolt	Vis 6 pans
25	934D20PA	2	Sechskantmutter	M20 DIN934-8 verz.	Hex. nut	Ecrou 6 pans
26	8405.59.00	2,4	Führungsbolzen verzin		Pin	Axe
27	71412DA81	2,4	Schmiernippel	AM8x1 DIN71412	Grease nippel	Graisseur
28	1481D640A	2,4	Spannstift	6x40 DIN1481 verz.	Dowel pin	Goupille serrage
29	7606.13.01	1	Sicherungskette		Safety chain	Chaîne
30	7606.15.01	1	Verstellstück, links		Link arm l.h.	Bras gauche

Ersatzteilliste



F

Hydr. Dreipunktgestänge
Rear hitch hydr.
Attelage hydr.

Drill-Lift

Bild Ref. Fig.	Bestellnr. Part.-No. Référence	Stck Qty. Qte.	Bezeichnung	Technische Angaben Technical data Données techniques	Description	Désignation
30	7606.15.02	1	Verstellstück, rechts		Link arm r.h.	Bras droit
31	7002.05.00	4	Spannstift mit Wellensc	25x32	Dowel pin	Goupille serrage
32	933D2075N	4	Sechskantschraube	M20x75 DIN933-10.9	Hex. bolt	Vis 6 pans
33	980DV20P	4	Sicherungsmutter	VM20 DIN980-8	Lock nut	Ecrou frein
34	7606.16.01	1	Querrohr		Connect. pipe	Bras de raccord.
35	7606.09.02	1	Seitenarm, links		Side arm l.h.	Bras laterale gauche
36	7606.09.01	1	Seitenarm, rechts		Side arm r.h.	Bras laterale droit
37	8413.38.00	2,4	Verstellarmbolzen verz.		Pin	Axe
38	933D1225NA	2,4	Sechskantschraube	M12x25 DIN933-10.9 verz.	Hex. bolt	Vis 6 pans
39	127DA12A	2,4	Federring	A12 DIN127 verz.	Springwasher	Rondelle grower
40	71412DB81	2,4	Schmiernippel	BM8x1 DIN71412	Grease nippel	Graisser
41	1441D26A	4	Scheibe	26 DIN1441 verz.	Washer	Rondelle
42	7606.08.01	2	Lagerbock		Bracket	Support
43	960D201570N	4	Sechskantschraube	M20x1,5x70 DIN960-10.	Hex. bolt	Vis 6 pans
44	980DV2015N	4	Sicherungsmutter	VM20x1,5 DIN980-10	Lock nut	Ecrou frein
45	7606.07.04	1	Anschlagplatte		Latch	Plat
46	960D161565M	2	Sechskantschraube	M16x1,5x65 DIN960-12.	Hex. bolt	Vis 6 pans
47	8405.00.18	2	Poly-Stop-Sechskantm	M16x1,5	Poly-Stop nut	Ecrou Poly-Stop

Ersatzteilliste



G

Hydr. Aushub bis 4,5 m

Relevage hydr. jusqu'à 4,5 m

DRILL-LIFT

Hydr. lifting up to 4,5 m

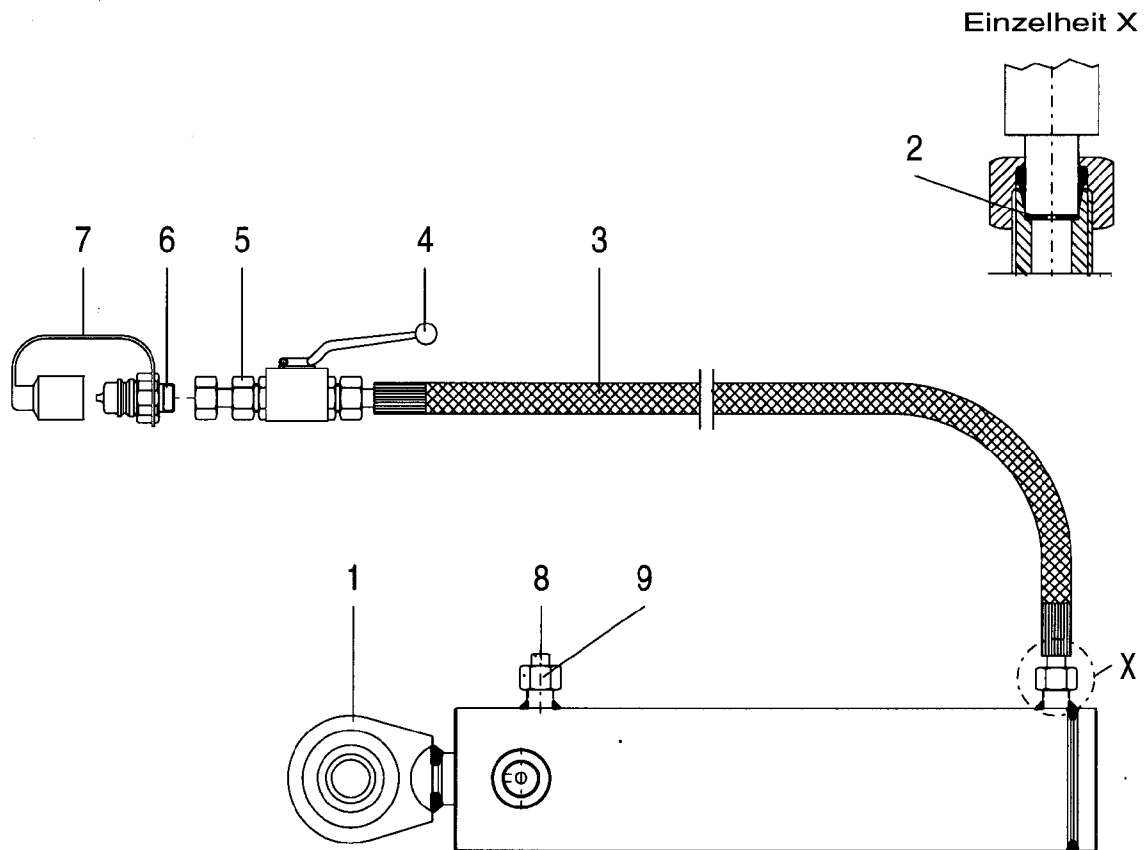

Ersatzteilliste



G

Hydraulischer Aushub
Hydraulic lifting
Relevage hydraulique

Drill-Lift

Bild Ref. Fig.	Bestellnr. Part.-No. Référence	Stck Qty. Qte.	Bezeichnung	Technische Angaben Technical data Données techniques	Description	Désignation
1-9	7606.06.01	1	HYDR. AUSHUB		HYDR. LIFTING	RELEVAGE HYDR.
1	8168.03.01	1	Zylinder	80/35/300	Cylinder	Verin
2	8132.06.04	1	Drosselscheibe	Ø2,5	Restrictive washer	Etranglement
3	8413.88.02	1	Hydraulikschlauch	L=1500 mm	Hydr. hose	Conduite flexible
4	4716.46.05	1	HD-Blockkugelhahn	NW-10	Ball valve	Robinet
5	4716.53.05	1	Hydraulikrohr mont.	L=40 mm	Hydr. pipe	Tube
6	8132.01.00	1	Kupplungsstecker	ISO 5675	Coupling	Raccord
7	8132.05.01	1	Staubkappe rot		Dust cap red	Cache rouge
8	6432.58.23	1	Rohrverschlußbutzen	BUZ-12L/S	Nipple	Bouchon
9	4716.46.04	1	Überwurfmutter	M 12-L	Union nut	Ecrou-raccord

Ersatzteilliste



G1

Zylinder 80/35/300
Cylinder 80/35/300
Verin 80/35/300

Drill-Lift

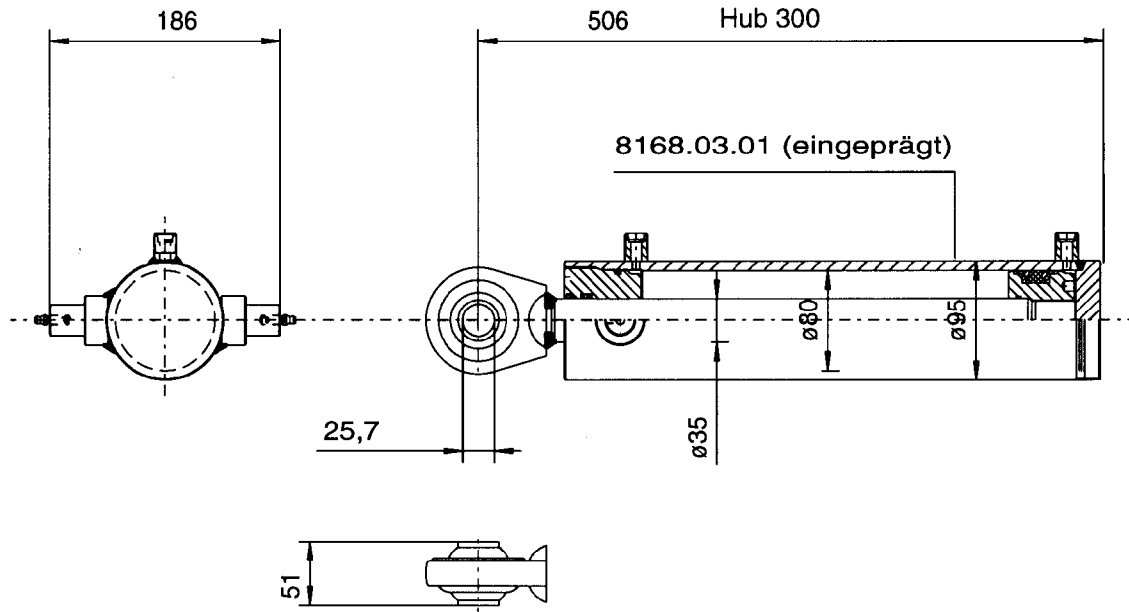

8168.03.01

Ersatzteilliste



G1

Zylinder 8168.03.01
 Cylinder
 Verin

Drill-Lift

Bild Ref. Fig.	Bestellnr. Part.-No. Référence	Stck Qty. Qte.	Bezeichnung	Technische Angaben Technical data Données techniques	Description	Désignation
	8168.03.01		Zylinder	80/35/300	Cylinder	Verin
	8168.06.04		Dichtungssatz		Seal kit	Jeu de jointe

Ersatzteilliste



H

Hubbegrenzung

Lift limiter

Butée de limitation de course

Drill-Lift

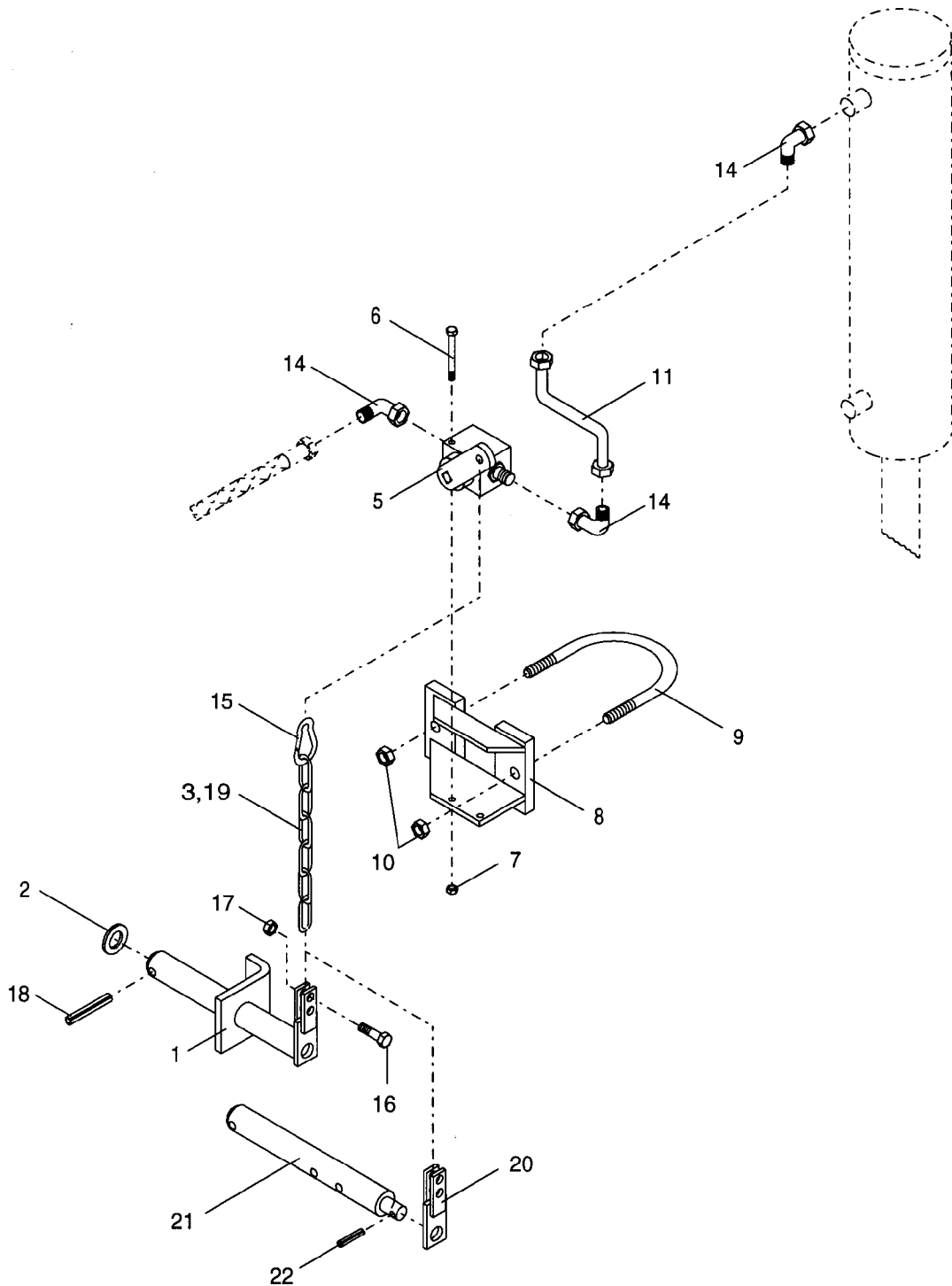

8423.80.01

8423.28.00

Ersatzteilliste

**H**
 Hubbegrenzung
 Lift limiter
 Butée de limitation de course
Drill-Lift

Bild Ref. Fig.	Bestellnr. Part.-No. Référence	Stck Qty. Qte.	Bezeichnung	Technische Angaben Technical data Données techniques	Description	Désignation
1-18	8423.80.01	1	HUBBEGRENZUNG	3,0 M	LIFT LIMITER	BUTEE DE LIMIT.DE
5-22	8423.28.00	1	HUBBEGRENZUNG	-4,5M / HKE+VKE -5,0M	LIFT LIMITER	BUTEE DE LIMIT.DE
1	8423.78.01	1	Zylinderbolzen		Pin	Axe
2	126D26	4	Scheibe	6 DIN126	Washer	Rondelle
3	763D0,416K4	1	Kette	0,416m-4 DIN763	Chain	Chaîne
5	8423.31.01	1	Hubbegrenzer		Lift limiter	Limiteur de levée
6	931D650P	2	Sechskantschraube	M6x50 DIN931-8.8	Hex. bolt	Vis 6 pans
7	934D6PA	2	Sechskantmutter	M6 DIN934-8 verz.	Hex. nut	Ecrou 6 pans
8	8423.30.00	1	Ventilhalter		Valve holder	Bride soupape
9	8423.28.01	1	Schraubband		Cross section	Bride
10	934D10PA	2	Sechskantmutter	M10 DIN934-8 verz.	Hex. nut	Ecrou 6 pans
11	8423.28.03	1	Hydraulikrohr	L=207 mm	Hydr. pipe	Tube
14	4716.52.11	3	Einstellb. Winkelversch	EVW-12 L	Elbow coupling	Raccord
15	8423.28.05	1	Feuerwehr-Karabinerh		Carbine swivel	Mousqueton
16	933D825P	1	Sechskantschraube	M8x25 DIN933-8.8	Hex. bolt	Vis 6 pans
17	934D8PA	1	Sechskantmutter	M8 DIN934-8 verz.	Hex. nut	Ecrou 6 pans
18	1481D850	1/2	Spannstift	8x50 DIN1481	Dowel pin	Goupille serrage
19	763D0,640K4	1	Kette	0,640m-4 DIN763	Chain	Chaîne
20	8423.29.00	1	Lasche		Latch	Plat
21	8423.28.02	2	Zylinderbolzen		Pin	Axe
22	1481D630	1	Spannstift	6x30 DIN1481	Dowel pin	Goupille serrage

Ersatzteilliste



J

Frontanbau
Front mounting
Montage poussée

Kreiselleggen, Rotoren

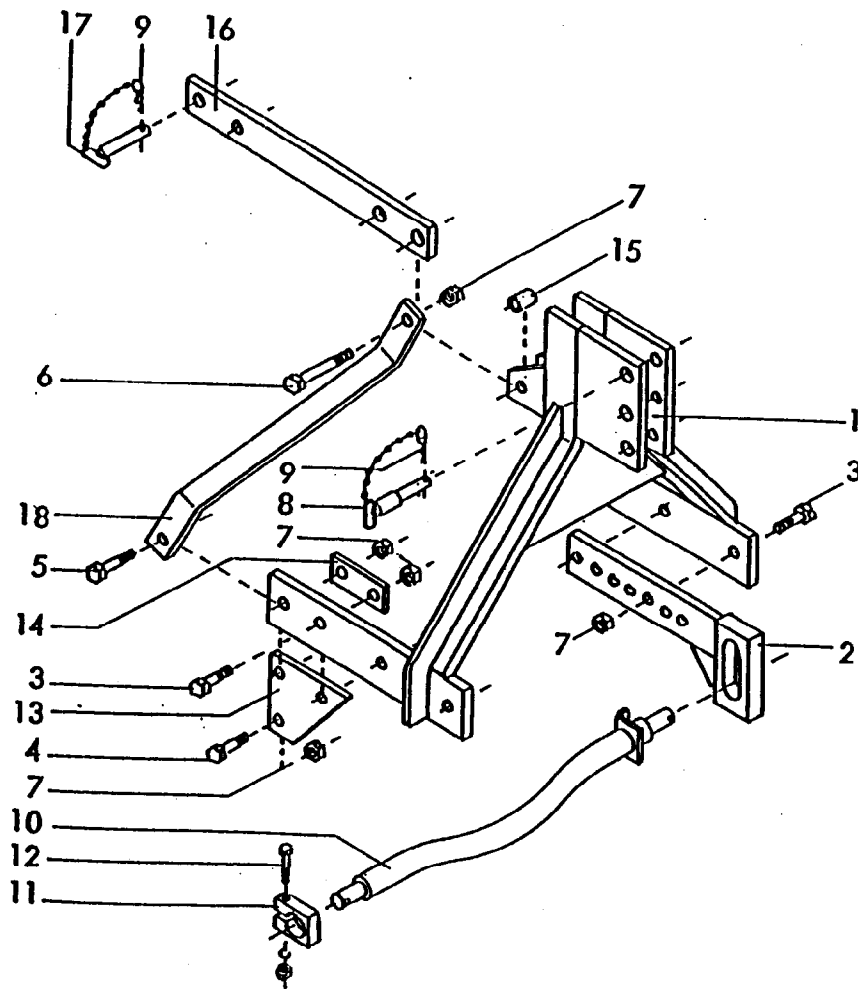

Ersatzteilliste



J

Frontanbau
Front mounting
Montage poussée

Kreiseleggen, Rotoren

Bild Ref. Fig.	Bestellnr. Part.-No. Référence	Stck Qty. Qte.	Bezeichnung	Technische Angaben Technical data Données techniques	Description	Désignation
1	8406.65.00	1	Frontturm		Front headstock	Tête
2	8411.04.04	2	Anschlußstück		Connecting bracket l.h	Support à visser, gauche
3	933D2060P	6	Sechskantschraube	M20x60 DIN933-8.8	Hex. bolt	Vis 6 pans
4	931D2065P	2	Sechskantschraube	M20x65 DIN931-8.8	Hex. bolt	Vis 6 pans
5	931D2075P	2	Sechskantschraube	M20x75 DIN931-8.8	Hex. bolt	Vis 6 pans
6	931D20140P	1	Sechskantschraube	M20x140 DIN931-8.8	Hex. bolt	Vis 6 pans
7	980DV20P	11	Sicherungsmutter	VM20 DIN980-8	Lock nut	Ecrou frein
8	6333.09.00	1	OI-Stock	Kat.2	Top link pin	Axe 3 points
9	4716.35.00	2	Federsteckstock	BTB-4	R-clip	Goupille beta
10	8406.66.00	1	Dreipunktachse	Kat.2	Cross shaft	Axe d'attelage
11	8413.00.41	1	Klemmstück		Clamp plate	Pièce de serrage
12	931D1290P	1	Sechskantschraube	M12x90 DIN931-8.8	Hex. bolt	Vis 6 pans
12	127DA12	1	Federring	A12 DIN127	Springwasher	Rondelle grower
12	934D12P	1	Sechskantmutter	M12 DIN 934-8	Hex. nut	Ecrou 6 pans
13	8406.54.02	2	Anschraubplatte	MKE -Br.2, EMKE,WMK	Connecting plate	Plaque à visser
13	8406.54.07	2	Anschraubplatte	MKE Br.3+, PKE,SKE,R	Connecting plate	Plaque à visser
14	8406.54.08	2	Distanzplatte	Rotor LR	Spacer plate	Entretoise
15	8406.54.01	1	Distanzhülse		Spacer	Bague entretoise
16	8406.54.05	1	Turmstrebe	MKE -Br.2, EMKE,WMK	Strut	Support
16	8406.54.06	1	Turmstrebe	MKE Br.3+, PKE,SKE,R	Strut	Support
17	8007.13.00	1	Steckstock	TB-25x110 A	Pin	Axe
18	8406.54.03	2	Haltestrebe		Strut	Support

Ersatzteilliste



K

Satteldreieck
A-frame (male)
Triangle d'attelage

Kreiselleggen

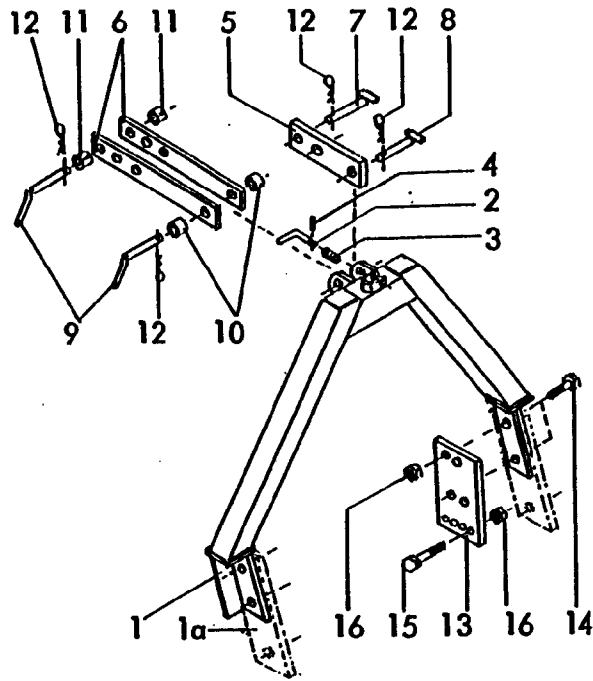

Ersatzteilliste



K

Satteldreieck
A-frame (male)
Triangle d'attelage

Kreiseleggen

Bild Ref. Fig.	Bestellnr. Part.-No. Référence	Stck Qty. Qte.	Bezeichnung	Technische Angaben Technical data Données techniques	Description	Désignation
1	8426.30.00	1	Satteldreieck		A-frame (male)	Triangle d'attelage
1a	8426.31.00	1	Satteldreieck	MKE+Schaltgetr.	A-frame (male)	Triangle d'attelage
2	8412.55.05	1	Steckbolzen		Pin	Broche
3	8412.55.06	1	Druckfeder verzinkt		Compression spring	Ressort
4	8412.55.07	1	Spannstift	6x40 DIN1481 verz.	Dowel pin	Goupille serrage
5	8419.03.01	1	Oberlenkerstrebe	EMKE, WMKE	Strut	Support
6	8412.55.02	2	Oberlenkerstrebe	MKE+Schaltgetr., SKE	Strut	Support
6	8412.55.03	2	Oberlenkerstrebe	PKE	Strut	Support
6	8412.55.08	2	Oberlenkerstrebe	MKE	Strut	Support
7	2614.18.00	1	Zugbolzen verzinkt		Pin	Axe
8	8007.13.00	1	Steckstock	TB-25x110 A	Pin	Axe
9	8404.74.00	2	Steckstock	TB-25x170 A	Pin	Axe
10	8412.55.04	2	Distanzrohr		Spacer	Entretoise
11	1498D253228	2	Buchse	EG 25/32x28 DIN1498	Bush	Douille
12	4716.35.00	2	Federsteckstock	BTB-4	R-clip	Goupille beta
13	8412.55.10	2	Verstellplatte		Adjust. Plate	Plaque de réglage
14	933D2050P		Sechskantschraube	M20x50 DIN933-8.8	Hex. bolt	Vis 6 pans
15	931D2070P	2	Sechskantschraube	M20x70 DIN931-8.8	Hex. bolt	Vis 6 pans
16	980DV20P	6	Sicherungsmutter	VM20 DIN980-8	Lock nut	Ecrou frein
.						
.						
.						
.						
.						
.						
.						
.						
.						
.						
.						
.						
.						
.						
.						
.						
.						

Ersatzteilliste



L

Leitblech
Deflector
Deflecteur

Kreiselleggen

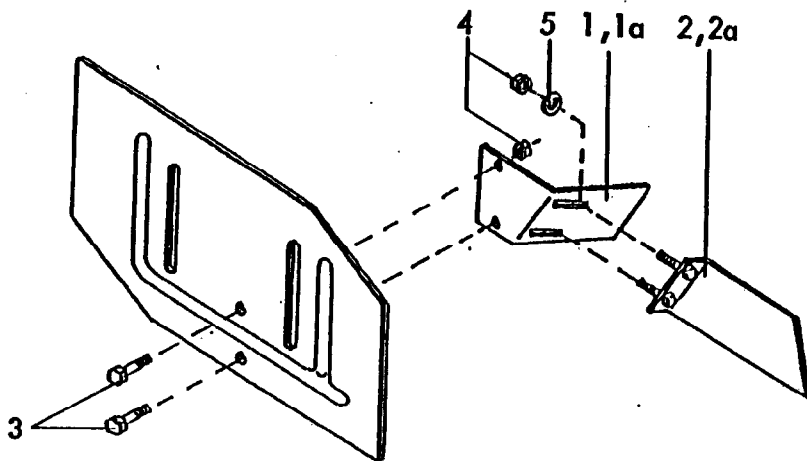



L

Leitblech
Deflector
Deflecteur

Kreiseleggen

Bild Ref. Fig.	Bestellnr. Part.-No. Référence	Stck Qty. Qte.	Bezeichnung	Technische Angaben Technical data Données techniques	Description	Désignation
1	8413.55.01	1	Leitblech rechts		Deflector r.h.	Deflecteur droit
1a	8413.55.02	1	Leitblech links		Deflector l.h.	Deflecteur gauche
2	8413.56.01	1	Leitblech hinten rechts		Rear deflector r.h.	Deflecteur arrière droit
2a	8413.56.02	1	Leitblech hinten links		Rear deflector l.h.	Deflecteur arrière gauche
3	933D1025N	4	Sechskantschraube	M10x25 DIN933-10.9	Hex. bolt	Vis 6 pans
4	980DV10N	8	Sicherungsmutter	VM10 DIN980-10	Lock nut	Ecrou frein
5	440DR11A	4	Scheibe	R11 DIN440 verz.	Washer	Rondelle

Ersatzteilliste



M

Prallblech
Clod bar
Chicane

Kreiselleggen

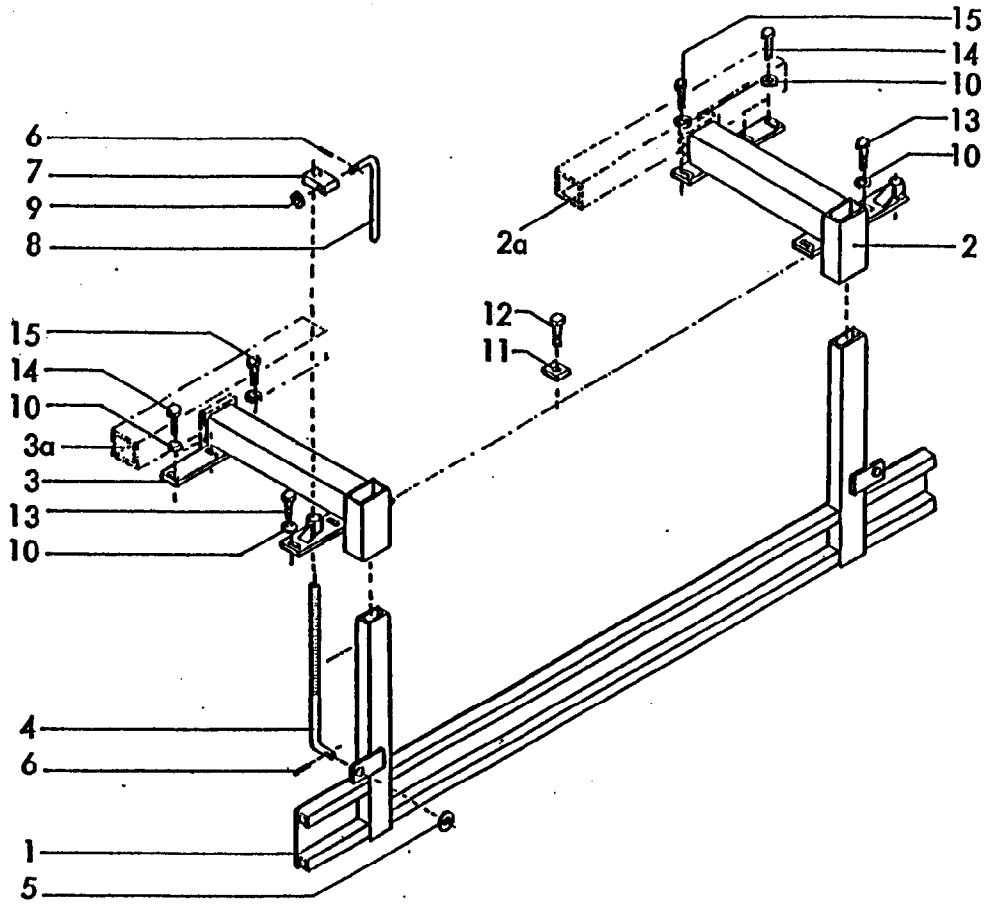

Ersatzteilliste

**M**Prallblech
Clod bar
Chicane**EMKE, WMKE, MKE, PKE, SKE**

Bild Ref. Fig.	Bestellnr. Part.-No. Référence	Stck Qty. Qte.	Bezeichnung	Technische Angaben Technical data Données techniques	Description	Désignation
1	8413.53.18	1	Prallschiene	2,0m	Clod bar	Chicane
1	8413.53.23	1	Prallschiene	2,5m	Clod bar	Chicane
1	8413.53.25	1	Prallschiene	3,0m	Clod bar	Chicane
1	8413.53.29	1	Prallschiene	3,0m SKE	Clod bar	Chicane
1	8413.53.21	1	Prallschiene	3,5m	Clod bar	Chicane
1	8413.53.28	1	Prallschiene	4,0m	Clod bar	Chicane
1	8413.53.31	1	Prallschiene	4,5m	Clod bar	Chicane
2	8413.52.01	1	Träger rechts		Bracket r.h.	Support droit
3	8413.52.02	1	Träger links		Bracket l.h.	Support gauche
2	8423.22.02	1	Träger rechts	SKE 300	Bracket r.h.	Support droit
3	8423.22.01	1	Träger links	SKE 300	Bracket l.h.	Support gauche
2a	8419.45.02	1	Kombiträger, rechts	EMKE+WMKE 200	Combi bracket r.h.	Support combi.droit
3a	8419.45.03	1	Kombiträger, links	EMKE+WMKE 200	Combi bracket l.h.	Support combi.gauche
2a	8426.40.02	1	Kombiträger, rechts	2,5m	Combi bracket r.h.	Support combi.droit
3a	8426.40.01	1	Kombiträger, links	2,5m	Combi bracket l.h.	Support combi.gauche
4	8413.54.01	2	Spindel verzinkt		Spindle	Manivelle
5	126D26	2	Scheibe	6 DIN126	Washer	Rondelle
6	1481D530	4	Spannstift	5x30 DIN1481	Dowel pin	Goupille serrage
7	8413.54.02	2	Spindelverstellung		Depth adjust.	Goupille élastique
8	8409.00.34	2	Drehgriff		Crank	Broche
9	126D14	2	Scheibe	14 DIN126	Washer	Rondelle
10	7349D13A	12	Scheibe	13 DIN7349 verz.	Washer	Rondelle
11	8413.00.37	2	Unterlage		Shim	Cale
12	8426.13.03	2	Verbus-Ripp-Sechskan	M12x45-100	Verbus-Ripp bolt	Boulon hex. indesserable
12	931D1245M	2	Sechskantschraube	M12x45 DIN931-12.9	Hex. bolt	Vis 6 pans
13	8426.13.02		Verbus-Ripp-Sechskan	M12x35-100	Verbus-Ripp bolt	Boulon hex. indesserable
14	8426.13.04		Verbus-Ripp-Sechskan	M12x55-100	Verbus-Ripp bolt	Boulon hex. indesserable
15	8426.13.03		Verbus-Ripp-Sechskan	M12x45-100	Verbus-Ripp bolt	Boulon hex. indesserable

Ersatzteilliste



N

Segment-Schutzschiene, hinten
Protection bar rear
Barre de protection arrière

PKE , MKE

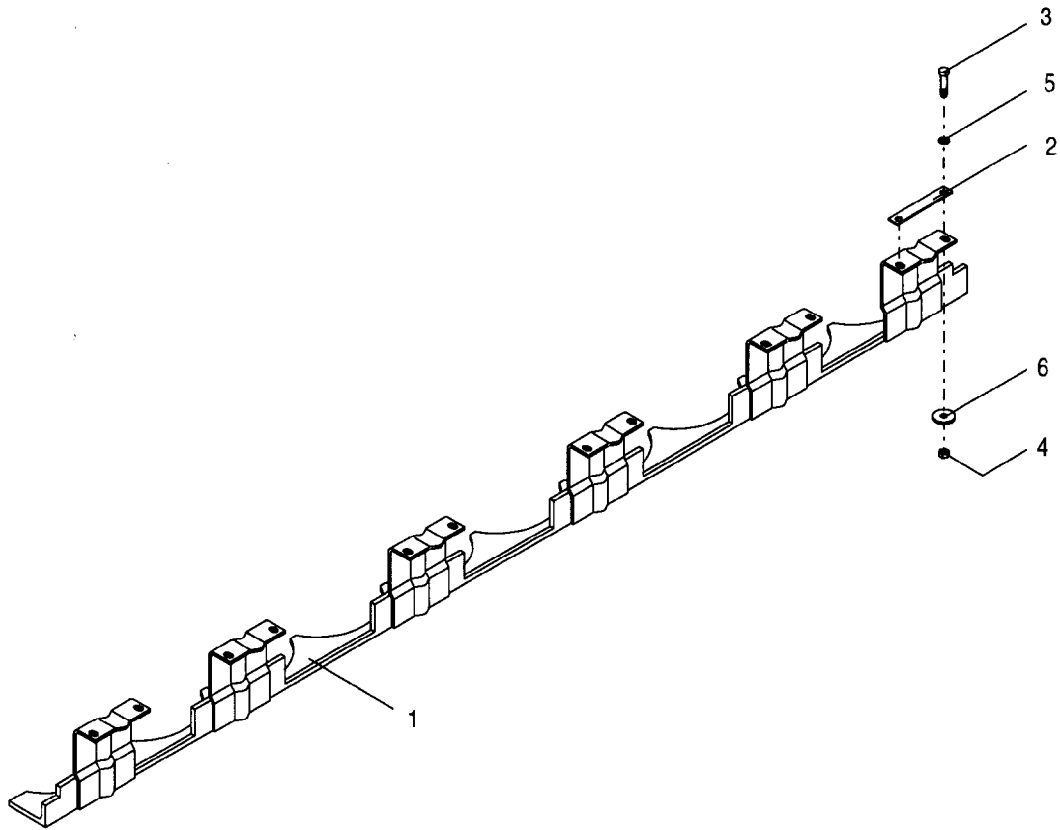

Ersatzteilliste



N

Segmenten-Schutzschiene, hinten
Rear protection bar
Barre de protection arrière

MKE, PKE

Bild Ref. Fig.	Bestellnr. Part.-No. Référence	Stück Qty. Qte.	Bezeichnung	Technische Angaben Technical data Données techniques	Description	Désignation
1	8426.07.02	1	Schutzschiene, hinten	MKE 250	Rear protection bar	Barre de protection arrière
1	8426.07.01	1	Schutzschiene, hint. li.	MKE 300	Rear protection bar l.h	Barre de protection ar/ga
1	8426.07.04	1	Schutzschiene, hint. re.	MKE 300	Rear protection bar r.h	Barre de protection ar/dr
1	8426.07.05	1	Schutzschiene, hint. li.	MKE 400	Rear protection bar l.h	Barre de protection ar/ga
1	8426.07.06	1	Schutzschiene, hint. re.	MKE 400	Rear protection bar r.h	Barre de protection ar/dr
1	8413.87.01	1	Schutzschiene, hinten	PKE 250	Rear protection bar	Barre de protection arrière
1	8413.87.02	1	Schutzschiene, hint. li.	PKE 300	Rear protection bar l.h	Barre de protection ar/ga
1	8413.87.08	1	Schutzschiene, hint. re.	PKE 300	Rear protection bar r.h	Barre de protection ar/dr
1	8413.87.03	1	Schutzschiene, hint. Li	PKE 400	Rear protection bar l.h	Barre de protection ar/ga
1	8413.87.09	1	Schutzschiene, hint. re.	PKE 400	Rear protection bar r.h	Barre de protection ar/dr
1	8413.87.06	1	Schutzschiene, hint. li.	PKE 450	Rear protection bar l.h	Barre de protection ar/ga
1	8413.87.07	1	Schutzschiene, hint. re.	PKE 450	Rear protection bar r.h	Barre de protection ar/dr
2	8411.00.29		Unterlage		Shim	Cale
3	8426.13.03		Verbus-Ripp-Sechskan	M12x45-100	Verbus-Ripp bolt	Boulon hex. indesserable
3	8426.13.04		Verbus-Ripp-Sechskan	M12x55-100	Verbus-Ripp bolt	Boulon hex. indesserable
3	931D1245M		Sechskantschraube	M12x45 DIN931-12.9	Hex. bolt	Vis 6 pans
3	931D1255M		Sechskantschraube	M12x55 DIN931-12.9	Hex. bolt	Vis 6 pans
3	931D1265M		Sechskantschraube	M12x65 DIN931-12.9	Hex. bolt	Vis 6 pans
3	931D1280M		Sechskantschraube	M12x80 DIN931-12.9	Hex. bolt	Vis 6 pans
4	8426.13.05		Verbus-Ripp-Sechskan	M12-10 verz.	Verbus-Ripp nut	Ecrou Verbus-Ripp
4	980DV12M		Sicherungsmutter	VM12 DIN980-12	Lock nut	Ecrou frein
5	7349D13A		Scheibe	13 DIN7349 verz.	Washer	Rondelle
6	6436.60.03		Scheibe	C-13	Washer	Rondelle
.	.		.			
.	.		.			
.	.		.			
.	.		.			
.	.		.			
.	.		.			
.	.		.			
.	.		.			
.	.		.			
.	.		.			
.	.		.			
.	.		.			
.	.		.			
.	.		.			
.	.		.			
.	.		.			

Ersatzteilliste



0

Radspurlockerer
Wheel eradikator
Effaceur de trace

Saatbettkomb., Kreisel-u. Schelbeneggen, PZ

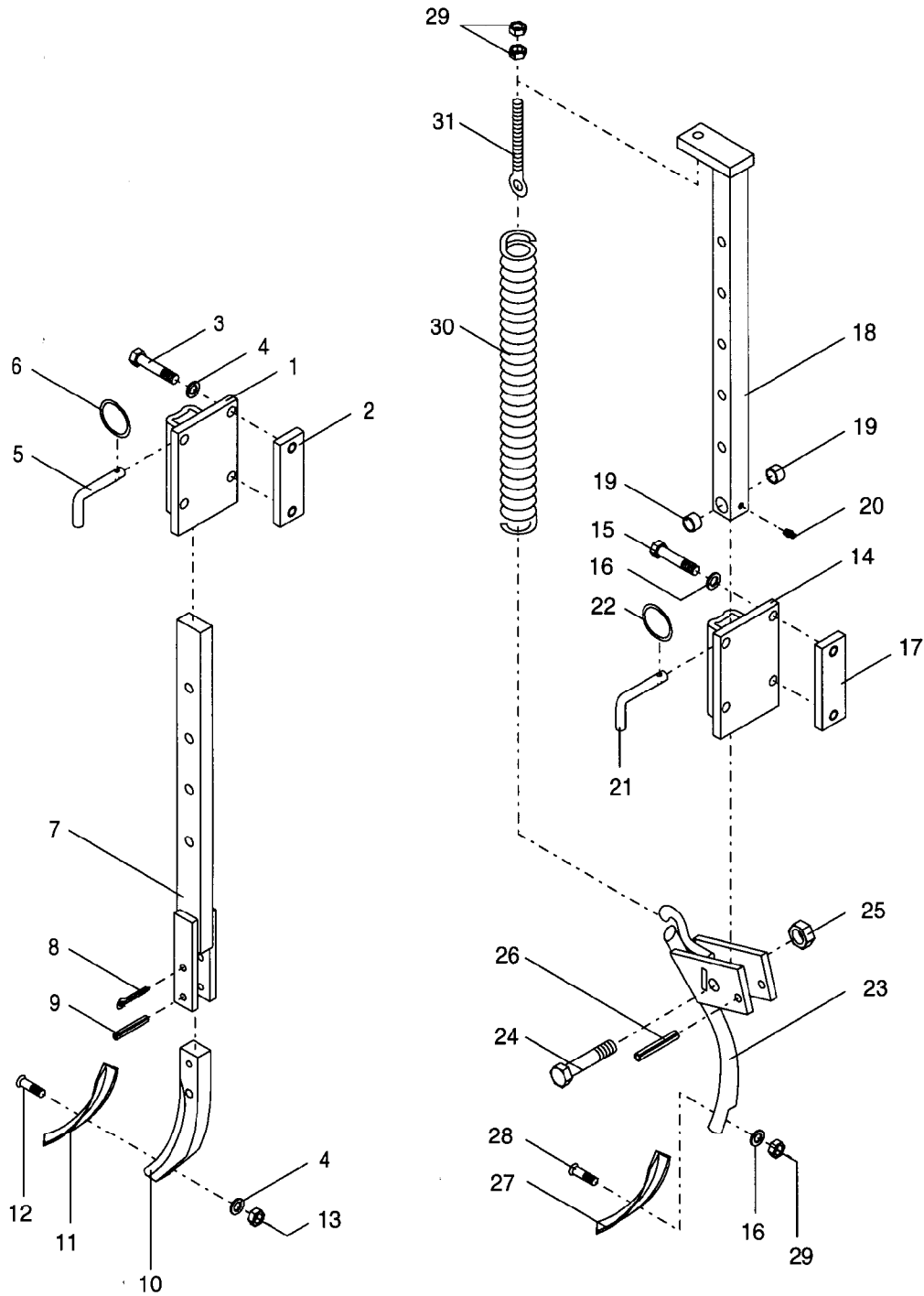

6241.29.00

6241.94.00

Ersatzteilliste



O

 Radspurlockerer
 Eradicator
 Effaceur de trace

 Saatbettkombinationen,
 Kreisel- und Scheibeneggen, Polygonwalze PZ

Bild Ref. Fig.	Bestellnr. Part.-No. Référence	Stck Qty. Qte.	Bezeichnung	Technische Angaben Technical data Données techniques	Description	Désignation
1-13	6241.29.00	1	RADSPURL. STARR		ERADICATOR CPL.	EFFACEUR CPL.
1	6241.39.00	1	Halter		Bracket	Support
2	6241.94.02	2	Gewindelasche		Latch	Plat
3	931D12110P	4	Sechskantschraube	M12x110 DIN931-8.8	Hex. bolt	Vis 6 pans
4	127DA12A	5	Federring	A12 DIN127 verz.	Springwasher	Rondelle grower
5	6241.29.02	1	Steckstock	TB-12x50	Pin	Axe
6	6608.12.07	1	Sicherungsring Draht	3A D2076C verz	Circlip	Circlip
7	6241.31.00	1	Stiel		Stalk	Tige
8	94D850	1	Splint	8x50 DIN94	Splint pin	Goupille fendue
9	1481D1045	1	Spannstift	10x45 DIN1481	Dowel pin	Goupille serrage
9	1481D645	1	Spannstift	6x45 DIN1481	Dowel pin	Goupille serrage
10	8007.24.04	1	Zinkenvorderteil		Tine	Support de soc
11	8007.30.01	1	Schar	GG-5	Share	Soc
12	8007.30.02	1	Scharschraube	SSS-12x40	Bolt	Vis
13	934D12PA	1	Sechskantmutter	M12 DIN934-8 verz.	Hex. nut	Ecrou 6 pans
14-31	6241.94.00	1	RADSPURL. GEFED.		ERADICATOR CPL.	EFFACEUR CPL.
14	6241.95.00	1	Tasche		Clamp plate	Console
15	931D12110P	4	Sechskantschraube	M12x110 DIN931-8.8	Hex. bolt	Vis 6 pans
16	127DA12A	5	Federring	A12 DIN127 verz.	Springwasher	Rondelle grower
17	6241.94.02	2	Gewindelasche		Latch	Plat
18	6241.96.00	1	Stiel		Stalk	Tige
19	1498D162012	2	Buchse	EG 16/20x12 DIN1498	Bush	Douille
20	4716.43.00	1	Schmiernippel	H2 8x1 KX-2	Grease nipple	Graisseur
21	6241.29.02	1	Steckstock	TB-12x50	Pin	Axe
22	6608.12.07	1	Sicherungsring Draht	3A D2076C verz	Circlip	Circlip
23	6241.97.00	1	Zinken		Tine	Dent
24	960D161565P	1	Sechskantschraube	M16x1,5x65 DIN960-8.8	Hex. bolt	Vis 6 pans
25	980DV1615P	1	Sicherungsmutter	VM16x1,5 DIN980- 8	Lock nut	Ecrou frein
26	1481D1050	1	Spannstift	10x50 DIN1481	Dowel pin	Goupille serrage
27	8007.30.01	1	Schar	GG-5	Share	Soc
28	8007.30.02	1	Scharschraube	SSS-12x40	Bolt	Vis
29	934D12PA	3	Sechskantmutter	M12 DIN934-8 verz.	Hex. nut	Ecrou 6 pans
30	6241.94.01	1	Zugfeder	CF-287	Tension spring	Ressort
31	6241.32.01	1	Ösenschraube	OS-12x70	Eyebolt	Piton

Ersatzteilliste



01

Träger für Radspurlockerer
Bracket for eradicator
Support pour effaceur

PKE, MKE

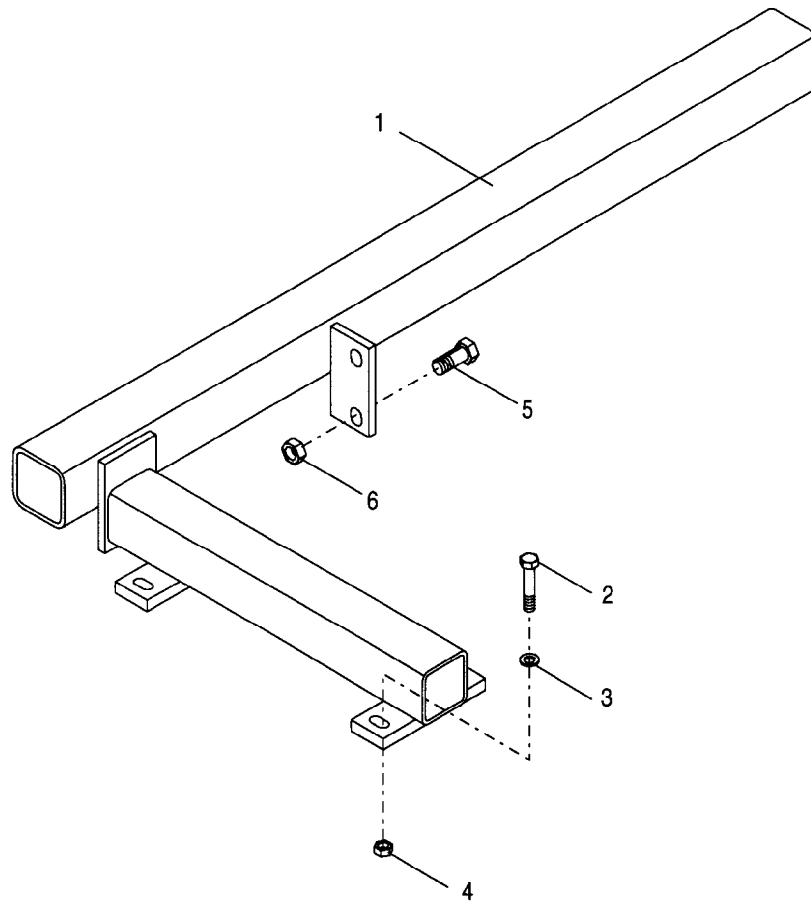

Ersatzteilliste

01

 Träger für Radspurlockerer
 Bracket for eradicator
 Support pour effaceur de trace

MKE, PKE

Bild Ref. Fig.	Bestellnr. Part.-No. Référence	Stck Qty. Qte.	Bezeichnung	Technische Angaben Technical data Données techniques	Description	Désignation
1	8426.40.01	1	Kombiträger, links	2,5m	Combi bracket l.h.	Support combi.gauche
1	8426.40.02	1	Kombiträger, rechts	2,5m	Combi bracket r.h.	Support combi.droit
1	8426.37.01	1	Träger links	3,0m	Bracket	Support
1	8426.37.02	1	Träger rechts	3,0m	Bracket	Support
1	8426.38.01	1	Träger links	3,5m	Bracket l.h.	Support gauche
1	8426.38.02	1	Träger rechts	3,5m	Bracket r.h.	Support droit
1	8426.39.01	1	Träger links	4,0m+PKE/SKE 4,5m	Bracket	Support
1	8426.39.02	1	Träger rechts	4,0m+PKE/SKE 4,5m	Bracket r.h.	Support droit
2	931D1245NA		Sechskantschraube	M12x45 DIN931-10.9 verz.	Hex. bolt	Vis 6 pans
2	931D1255NA		Sechskantschraube	M12x55 DIN931-10.9 verz.	Hex. bolt	Vis 6 pans
3	7349D13A		Scheibe	13 DIN7349 verz.	Washer	Rondelle
4	980DV12NA		Sicherungsmutter	VM12 DIN980-10 verz.	Lock nut	Ecrou frein
5	933D1640P		Sechskantschraube	M16x40 DIN933-8.8	Hex. bolt	Vis 6 pans
6	980DV16P		Sicherungsmutter	VM16 DIN980-8	Lock nut	Ecrou frein
.
.
.
.
.
.
.
.
.
.
.
.
.
.
.
.
.
.
.
.
.
.

Ersatzteilliste



P

Radspurlockerer RAMAT
Eradicator 'RAMAT'
Effaceur 'RAMAT'

PKE, SKE, Rotor

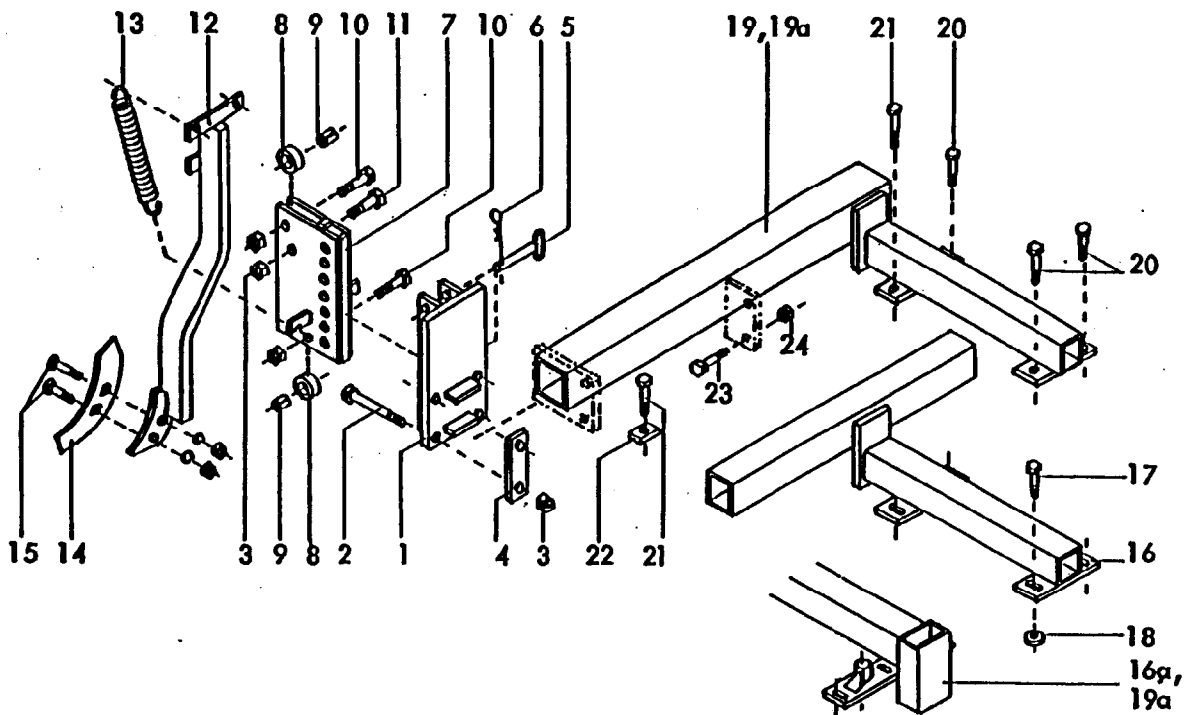

Ersatzteilliste



P

Radspurlockerer "RAMAT"
Eradicator "RAMAT"
Effaceur de trace "RAMAT"

PKE, SKE, Rotor

Bild Ref. Fig.	Bestellnr. Part.-No. Référence	Stck Qty. Qte.	Bezeichnung	Technische Angaben Technical data Données techniques	Description	Désignation
1-15	8416.39.01	1	RADSPURLOCKERER	RAMAT	ERADICATOR	EFFACEUR DE TRACE
1	8416.41.00	1	Verstellplatte		Adjust. Plate	Console
2	931D16130P	4	Sechskantschraube	M16x130 DIN931-8.8	Hex. bolt	Vis 6 pans
3	980DV16P	5	Sicherungsmutter	VM16 DIN980-8	Lock nut	Ecrou frein
4	8416.39.03	2	Lasche	LC-17X97	Latch	Plat
5	8416.43.00	2	Steckstock		Pin	Axe
6	4716.35.00	2	Federsteckstock	BTB-4	R-clip	Goupille beta
7	8416.40.00	1	Führungstasche		Guide plate	Console de guidage
8	8416.39.02	2	Rolle		Roller	Rouleau
9	7346D2122	2	Spannstift	21x22 DIN7346	Dowel pin	Goupille serrage
10	960D161560M	2	Sechskantschraube	M16x1,5x60 DIN960-12.	Hex. bolt	Vis 6 pans
10	980DV1615N	2	Sicherungsmutter	VM16x1,5 DIN980-10	Lock nut	Ecrou frein
11	931D1660P	1	Sechskantschraube	M16x60 DIN931-8.8	Hex. bolt	Vis 6 pans
12	8416.42.00	1	Spurlockererzinken	Ramat	Tine	Dent
13	8409.00.35	2	Zugfeder	CF-247	Tension spring	Ressort
14	8406.41.01	1	Schar	GG-60	Share	Soc
15	6337.06.03	2	Sondersenkschraube	BSSS-12X50	C sunk screw	Vis tête noyee
15	127DA12	2	Federring	A12 DIN127	Springwasher	Rondelle grower
15	934D12P	2	Sechskantmutter	M12 DIN 934-8	Hex. nut	Ecrou 6 pans
16	8413.71.00	2	Träger		Bracket	Support
16a	8413.97.01	1	Kombiträger links	PKE	Combi bracket l.h.	Support combi.gauche
16a	8413.97.02	1	Kombiträger rechts	PKE	Combi bracket r.h.	Support combi.droit
17	931D1245N	8	Sechskantschraube	M12x45 DIN931-10.9	Hex. bolt	Vis 6 pans
18	6437.00.01	8	Scheibe	C-132	Washer	Rondelle
19	8411.89.01	1	Träger links	3,0m	Bracket l.h.	Support gauche
19a	8411.89.02	1	Träger rechts	3,0m	Bracket r.h.	Support droit
19	8411.90.01	1	Träger links	4,0m	Bracket	Support
19a	8411.90.02	1	Träger rechts	4,0m	Bracket	Support
19	8411.93.01	1	Träger links	5,0m	Bracket l.h.	Support gauche
19a	8411.93.02	1	Träger rechts	5,0m	Bracket r.h.	Support droit
19	8411.94.01	1	Träger links	6,0m	Bracket l.h.	Support gauche
19a	8411.94.02	1	Träger rechts	6,0m	Bracket r.h.	Support droit
19	8423.23.01	1	Kombiträger links	SKE 400	Combi bracket l.h.	Support combi.gauche
19a	8423.23.02	1	Kombiträger rechts	SKE 400	Combi bracket r.h.	Support combi.droit
20	931D1245N	6	Sechskantschraube	M12x45 DIN931-10.9	Hex. bolt	Vis 6 pans
21	931D1260N	4	Sechskantschraube	M12x60 DIN931-10.9	Hex. bolt	Vis 6 pans

Ersatzteilliste



P

Radspurlockerer "RAMAT"
 Eradicator "RAMAT"
 Effaceur de trace "RAMAT"

PKE, SKE, Rotor

Bild Ref. Fig.	Bestellnr. Part.-No. Référence	Stck Qty. Qte.	Bezeichnung	Technische Angaben Technical data Données techniques	Description	Désignation
22	8416.39.04	2	Unterlage		Shim	Cale
23	933D1640P	4	Sechskantschraube	M16x40 DIN933-8.8	Hex. bolt	Vis 6 pans
24	980DV16P	4	Sicherungsmutter	VM16 DIN980-8	Lock nut	Ecrou frein



Gelenkwelle
PTO drive shaft
Transmission

W2500-SD25-760-K90/4R

Bestell-Nr.
Part No.
Référence

Zeichnungs-Nr.
Drawing No.
Réf. du plan

Datum
Date
Date
31.08.98

für Kunde
for customer
pour client

Rabewerk

Kundenzeichnung-Nr.
Customer drawing No.
Réf. du plan client

Maschinenart
Machine
Machine

VKE 300
EMKE/MNKE/MKE/PKE - 3.8m

Anschlußvariante-Schlepperseite
Connection variants-tractor side
Versions d'accouplement-côté tracteur

a = 1 3/8" (6)
b = 1 3/8" (21)
c = 1 3/4" (6)
d = 1 3/4" (20)

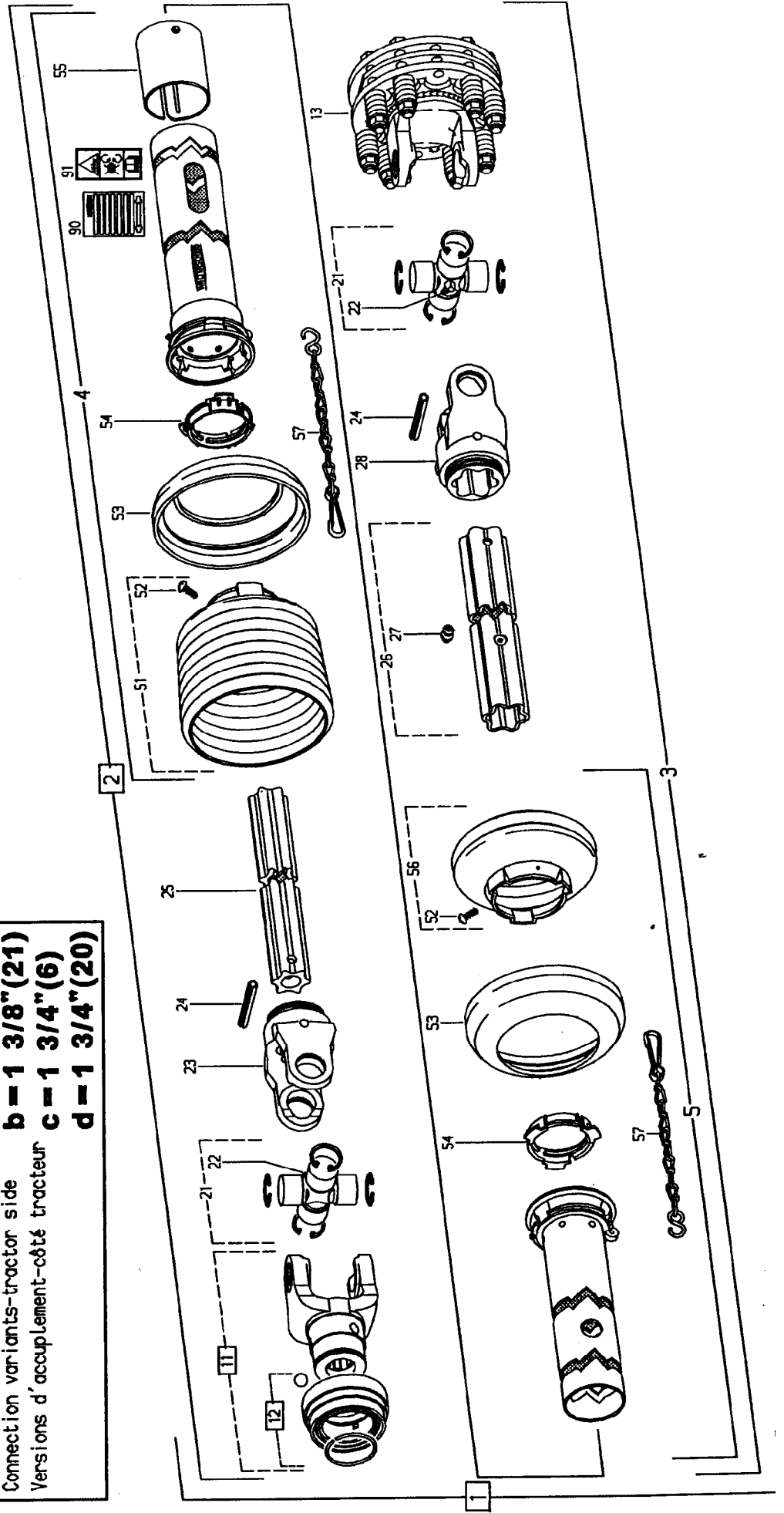

Pos.-Nr. Item Repère	Bestell.-Nr. Part No. Référence	Zeichnungs-Nr. Drawing No. Ref. du Plan	Stückzahl Quantity Quantité	Technische Angaben Technical data Données techniques	Benennung	Description	Désignation	Rabewerk Bestell.-Nr. Part No. Référence
1a	111780	14538	1	W2500- 1 3/8" (6)	Gelenkwelle mit Schutz	PTO drive shaft with guard	Transmission avec protecteur	8433.10.01
1b	111780	366800	1	W2500- 1 3/8" (21)				8433.10.02
1c	111780	366806	1	W2500- 1 3/4" (6)				8433.10.03
1d	111780	366808	1	W2500- 1 3/4" (20)				8433.10.04
2a	111778		1	WH2500- 1 3/8" (6)	Innere Gelenkwellenhälfte mit äußerer Schutzhälfte	Inner PTO drive shaft half with outer guard half	Demi-transmission intérieure avec demi-protecteur extérieur	
2b	111778	366800	1	WH2500- 1 3/8" (21)				
2c	111778	366806	1	WH2500- 1 3/4" (6)				
2d	111778	366808	1	WH2500- 1 3/4" (20)				
3	111779		1	WH2500-5025-651-K90/4R	Äußere Gelenkwellenhälfte mit innerer Schutzhälfte	Outer PTO drive shaft half with inner guard half	Demi-transmission extérieure avec demi-protecteur intérieur	
4	117033	85.255	1	SDH25-A520-PP7-K	Äußere Schutzhälfte	Outer guard half	Demi-protecteur extérieur	
5	117035	85.254	1	SDH25-J520-PP2-K	Innere Schutzhälfte	Inner guard half	Demi-protecteur intérieur	
11a	366798	36.83.00	1	Q562500-1 3/8" (6)	Q5-Gabel komplett	Q5-yoke complete	Môchoire Q5 complète	
11b	366800	36.83.02	1	Q562500-1 3/8" (21)				
11c	366806	36.84.00	1	Q562500-1 3/4" (6)				
11d	366808	36.84.02	1	Q562500-1 3/4" (20)				
12a+b	376106	agrazet 123	1	1 3/8"	Q5-Verschluß komplett; Größe C	Q5-lock complete; size C	Verrouillage Q5 complet; type C	
12c+d	376107	agrazet 124	1	1 3/4"	Reibkupplung; drehsinnunabhängig	Friction clutch; independent of direction of rotation	L'imitateur à friction; indépendant du sens de rotation	
13	376793	56.128.09	1	K90/4R-2500-1 3/4" (6) 90; M=1500Nm				
21	312209	36.00.00	2		Kreuzgarnitur komplett	Cross and bearing kit complete	Bloc croisillon complet	
22	084099	63.27.00	2	BM6x1	Kegel-Schmiernippel	Lubrication fitting	Graisseur	
23	097133	36.13.100	1	R62500-54	Rillengabel	Inboard yoke	Môchoire à gorge	
24	304046	61.05.12	2	DINI481-10x80	Spannstift	Spring type straight pin	Goupille élastique	
25	180606	75.44.21	1	54V-600	Profilwelle; vergütet	Profile shaft; tempered	Arbre profilé; trempé et revenu	
26	111777	75.45.153	1	55H-595	Profilrohr mit Schmiernippel	Profile tube with lubrication fitting	Tube profilé avec graisseur	
27	043427	63.11.02	1	AM6	Kegel-Schmiernippel	Lubrication fitting	Graisseur	
28	097140	36.14.100	1	R62500-55	Rillengabel	Inboard yoke	Môchoire à gorge	
51	365387	85.26.07	1	n=RP7	Schutzrichter; n= Rippenanzahl	Guard cone; n= Number of ribs	Cône protecteur; n= Nombre d'ondes	
52	365305	60.15.00	2	4x10	Schraube	Screw	Vis	
53	359474	82.85.03	2		Stützring	Reinforcing collar	Bague de renfort	
54	087276	82.83.04	2		Gleitring	Bearing ring	Bague de glissement	
55	188064	80.63.112	1		Abdeckung	Cover	Obturateur	
56	365382	85.26.02	1	n=RP2	Schutzrichter; n= Rippenanzahl	Guard cone; n= Number of ribs	Cône protecteur; n= Nombre d'ondes	
57	044321	82.36.03	2		Haltekette	Safety chain	Chaînette	
90	705066		1		Bedienungsanleitung (West)	Service instructions (West)	Notice d'emploi (Ouest)	
91	104689	16.61.175	1		Aufkleben - Gefahrenhinweis	Warning decal	Étiquette d'avertissement	



Gelenkwelle
PTO drive shaft
Transmission

W2500-SD25-760-EK64/2R

Bestell-Nr.
Part No.
Référence

Zeichnungs-Nr.
Drawing No.
Réf. du plan

Datum
Date
Date
31.08.98

für Kunde
for customer
pour client

Rabewerk

Kundenzeichnung-Nr.
Customer drawing No.
Réf. du plan client

Maschinenart
Machine
Machine

VKE 300

EMKE/MMKE/MKE/PKE - 3.8m

Anschlußvariante-Schlepperseite
Connection variants-tractor side
Versions d'accouplement-côté tracteur

a - 1 3/8" (6)
b - 1 3/8" (21)
c - 1 3/4" (6)
d - 1 3/4" (20)

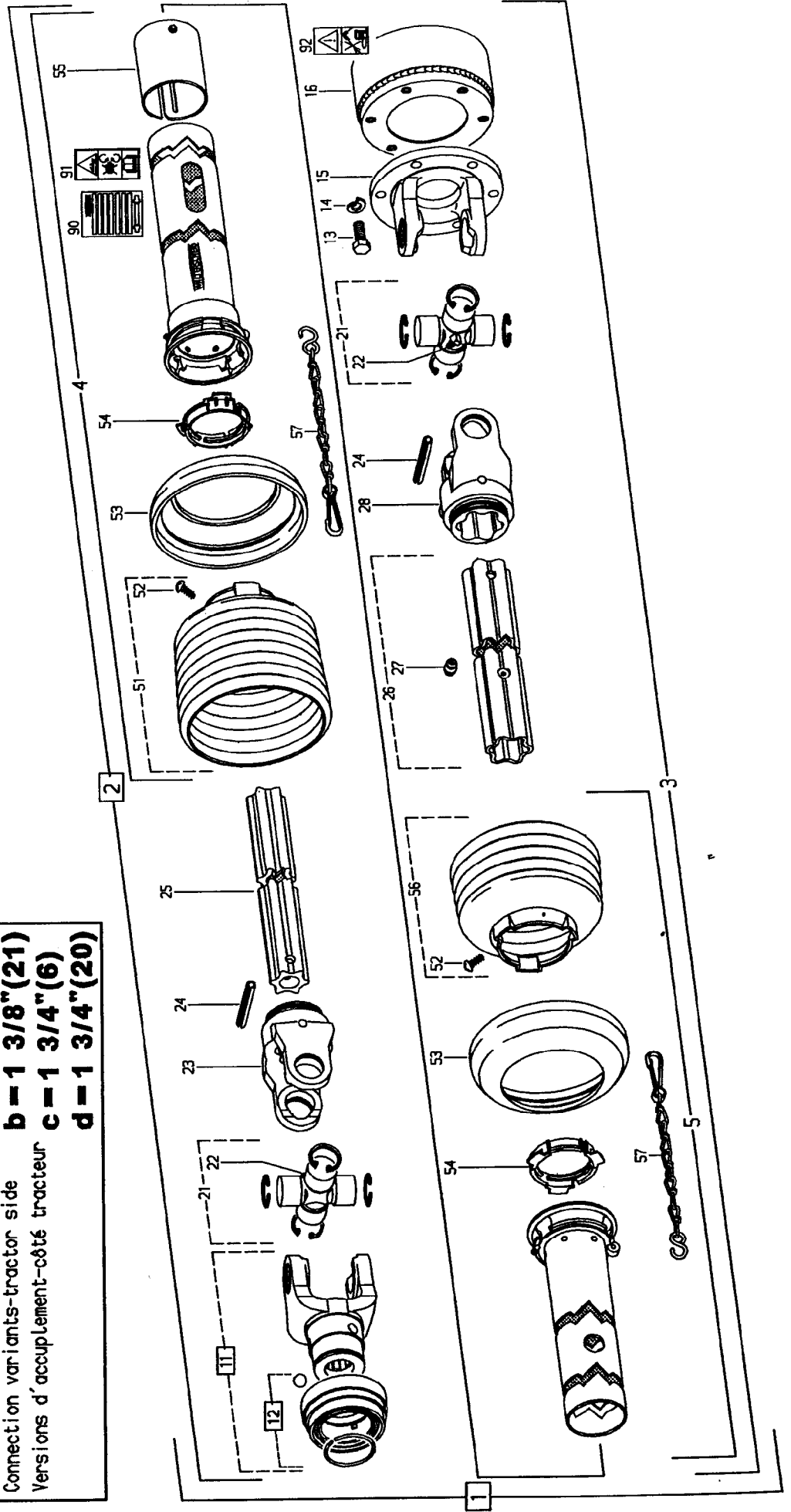

Pos.-Nr. Item Réfère	Bestell.-Nr. Part. No. Référence	Zeichnungs-Nr. Drawing No. Ref. du Plan	Stückzahl Quantity Quantité	Technische Angaben Technical data Données techniques	Benennung	Description	Désignation	Robewerk Bestell.-Nr. Part. No. Référence
1a	111782	14537	1	W2500-1 3/8" (6)	Gelenkwelle mit Schutz	PTO drive shaft with guard	Transmission avec protecteur	8433.11.01
1b	111782	366800	1	W2500-1 3/8" (21)				8433.11.02
1c	111782	366806	1	W2500-1 3/4" (6)				8433.11.03
1d	111782	366808	1	W2500-1 3/4" (20)				8433.11.04
2a	111778		1	WH2500-1 3/8" (6)	Innere Gelenkwellenhälfte mit äußerer Schutzhälfte	Inner PTO drive shaft half with outer guard half	Demi-transmission intérieure avec demi-protecteur extérieur	
2b	111778	366800	1	WH2500-1 3/8" (21)				
2c	111778	366806	1	WH2500-1 3/4" (6)				
2d	111778	366808	1	WH2500-1 3/4" (20)				
3	111781		1	WH2500-5D25-651-EK64/2R	Äußere Gelenkwellenhälfte mit innerer Schutzhälfte	Outer PTO drive shaft half with inner guard half	Demi-transmission extérieure avec demi-protecteur intérieur	
4	117033	85.255	1	SDH25-AS20-PP7-K	Äußere Schutzhälfte	Outer guard half	Demi-protecteur extérieur	
5	117034	85.254	1	SDH25-J520-PP6-K	Innere Schutzhälfte	Inner guard half	Demi-protecteur intérieur	
11a	366798	36.83.00	1	0562500-1 3/8" (6)	05-6abel komplett	05-yoke complete	Mâchoire 05 complète	
11b	366800	36.83.02	1	0562500-1 3/8" (21)				
11c	366806	36.84.00	1	0562500-1 3/4" (6)				
11d	366808	36.84.02	1	0562500-1 3/4" (20)				
12a+b	376106	09raset 123	1	1 3/8"	05-Verschluß komplett; Größe C	05-lock complete; size C	Verrouillage 05 complet; type C	
12c+d	376107	09raset 124	1	1 3/4"				
13	020531	60.06.05	6	DIN933-M12x30	Sechskantschraube	Hexagon screw	Boulon hexagonal	
14	020106	60.83.00	6	DINI27-A12	Federring	Lock washer	Rondelle élastique	
15	317807	36.19.02	1	FG2500-TK138/12(6)	Flanschgabel	Flange yoke	Mâchoire à bride	
16	110494	59.156.12	1	EK64/2R-1 3/4" (6)CC- TK138/M12(6); M=1600Nm	Nockenschalengkuppung; Rechtsdrehsinn	Cam-type out out clutch; right-hand rotation	Limiteur débroyable à cames; rotation à droite	
21	312209	36.00.00	2		Kreuzgarnitur komplett	Cross and bearing kit complete	Bloc croisillon complet	
22	084099	63.27.00	2	BH6x1	Kegel-Schmiernippel	Lubrication fitting	Graisseur	
23	097133	36.13.100	1	R62500-S4	Rillengabel	Inboard yoke	Mâchoire à gorge	
24	304046	61.05.12	2	DINI481-10x80	Spannstift	Spring type straight pin	Goupille élastique	
25	180506	75.44.21	1	SAV-600	Profilwelle; vergütet	Profile shaft; tempered	Arbre profilé; trempé et revenu	
26	111777	75.45.153	1	55H-595	Profiltröhr mit Schmiernippel	Profile tube with lubrication fitting	Tube profilé avec graisseur	
27	043427	63.11.02	1	AM6	Kegel-Schmiernippel	Lubrication fitting	Graisseur	
28	097140	36.14.100	1	R62500-S5	Rillengabel	Inboard yoke	Mâchoire à gorge	
51	365387	85.26.07	1	n-PP7	Schutzrichter; n= Rippenanzahl	Guard cone; n= Number of ribs	Cône protecteur; n= Nombre d'ondes	
52	365305	60.15.00	2	4x10	Schraube	Screw	Vis	
53	359474	82.85.03	2		Stützring	Reinforcing collar	Bague de renfort	
54	087276	82.83.04	2		Gleitring	Bearing ring	Bague de glissement	
55	186064	80.63.112	1		Abdeckung	Cover	Obturbateur	
56	365386	85.26.06	1	n-PP6	Schutzrichter; n= Rippenanzahl	Guard cone; n= Number of ribs	Cône protecteur; n= Nombre d'ondes	
57	044321	82.36.03	2		Haltekette	Safety chain	Chaînette	
90	705066		1		Bedienungsanleitung (West)	Service instructions (West)	Notice d'emploi (Ouest)	
91	104689	16.61.175	1		Aufkleber - Gefahrenhinweis	Warning decal	Étiquette d'avertissement	
92	117291	16.61.181	1		Verbotsschilder - Hochdruckreiniger	Prohibitive decal - high-pressure cleaner	Autocollant d'interdiction nettoyeur à haute pression	

WALTERSCHEID

Gelenkswelle
PTO drive shaft
Transmission **W2600-SD35-610-K96/4R**

Bestell-Nr.
Part no.
Référence

Zeichnungs-Nr.
Drawing no.
Réf. du plan

Datum
Date
Date **12.01.1988**

für Kunde
for customer
pour client

Rabewerk

Kundenbezeichnung-Nr.
Customer drawing no.
Réf. du plan client

- a=0.SG2600-1³/₈"(6)
- b=0.SG2600-1³/₈"(21)
- c=0.SG2600-1³/₄"(6)
- d=0.SG2600-1³/₄"(20)

Maschinenart
Machine
Machine

Type
Type
Type **PKE 400; SR 250-400;
SKE 300-600; Rotor
HKE, VKE**

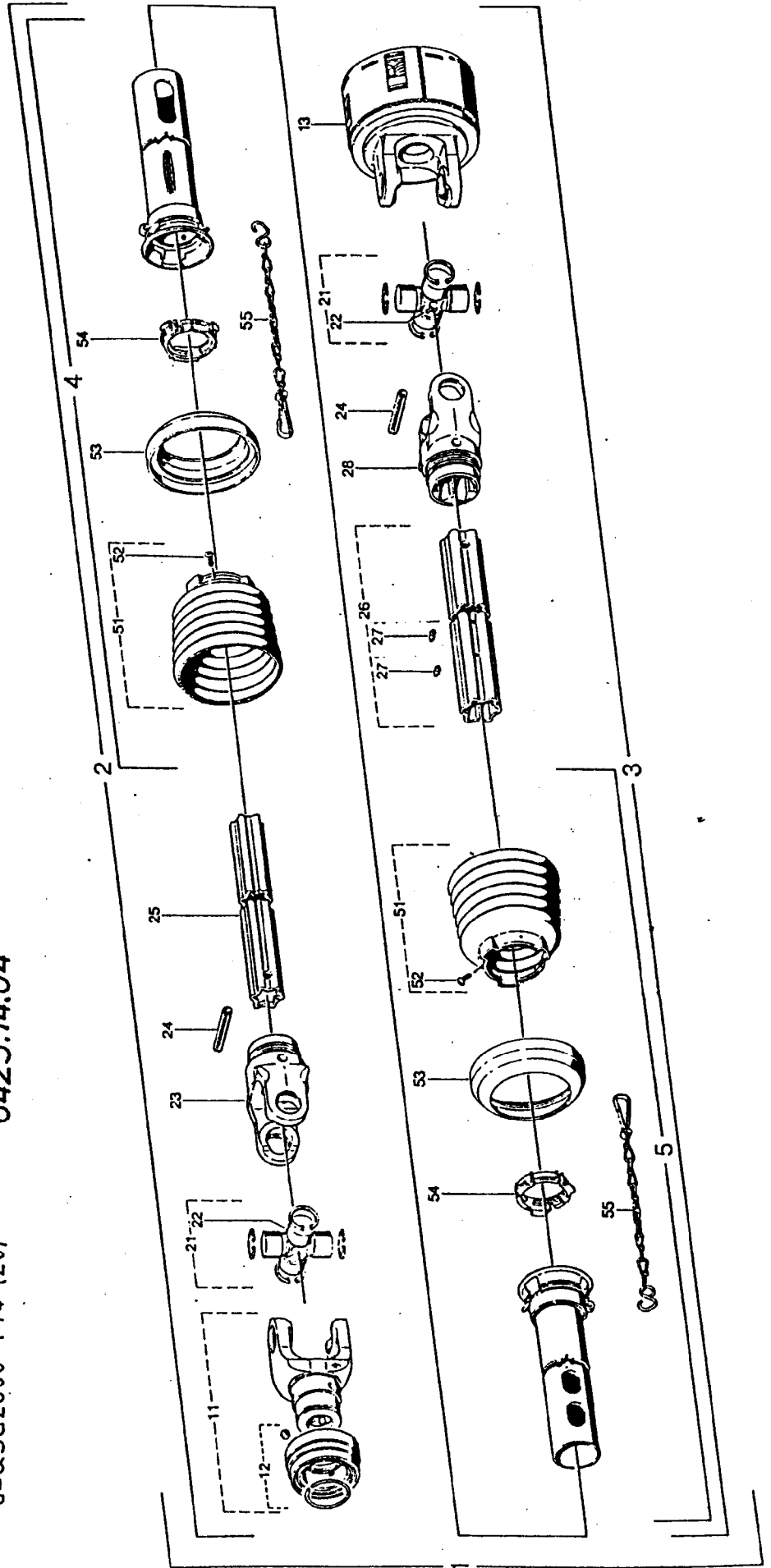

WALTERSCHEID
 Gelenkwelle PTO drive shaft W2600-SD35-610-K96/4R für PKE 400, SR 250-400, SKE 300-600, Rotor, HKE, VKE
 Transmission

Pos. Nr. / Part No. from Page	Bestell-Nr. Part No. Reference	Zusätzliche Drawing No. Reference	Stückzahl Quantity Quota	Technische Angaben Technical Dimensions	Bezeichnung	Description	Description	Rabe-Nr.
1a	176497	12114	1	W2600-SD35-610-K96/4R	Gelenkwelle mit Schutz	PTO drive shaft with guard	Transmission avec protecteur	8423.14.01
1b	17726	12161	1	W2600-SD35-610-K96/4R				8423.14.02
1c	17727	12162	1	W2600-SD35-610-K96/4R				8423.14.03
1d	17728	12163	1	W2600-SD35-610-K96/4R				8423.14.04
2a	16806		1	WH2600-SD35-507	Innere Gelenkwellenhälfte mit äußerer Schutzhälfte	Inner PTO drive shaft half with outer guard half	Demi-transmission intérieure avec demi-protecteur extérieur	8423.14.05
2b	17237		1	WH2600-SD35-507				8423.14.06
2c	17236		1	WH2600-SD35-507				8423.14.07
2d	17235		1	WH2600-SD35-507				8423.14.08
3	177161		1	WH2600-SD35-477-K96/4R	Äußere Gelenkwellenhälfte mit innerer Schutzhälfte	Outer PTO drive shaft half with inner guard half	Demi-transmission extérieure avec demi-protecteur intérieur	8423.14.09
4	178048	85.319	1	SDH35-A340	Äußere Schutzhälfte	Outer guard half	Demi-protecteur extérieur	
5	178049	85.320	1	SDH35-J340	Innere Schutzhälfte	Inner guard half	Demi-protecteur intérieur	
11a	365814	+26.84.00	1	QSG2600-17x161	Q.S.-Gabel komplett	Q.S.-yoke complete	Mâchoire Q.S. complète	
11b	365816	+26.84.02	1	QSG2600-17x121				
11c	365818	+26.84.04	1	QSG2600-17x161				
11d	366780	+26.84.06	1	QSG2600-17x120				
12a	376106	agrazet 123	1		Q.S.-Verschluss komplett; Größe C	Q.S.-lock complete; size C	Verrouillage Q.S. complet; type C	
12b	376106	agrazet 123	1					
12c	376107	agrazet 124	1					
12d	376107	agrazet 124	1					
13	177117	56.117.51	1	K96/4R-17x161Q.C; M=100Nm-1	Reibkupplung komplett; Rechtssdrehsinn	Friction clutch complete; clockwise rotation	Limiteur à friction complet; rotation à droite	
21	376245	26.00.00	2		Kreuzgarnitur komplett	Cross and bearing kit complete	Bloc croisillon complet	
22	084099	63.27.00	2	M8x1	Kegel-Schmiernippel	Lubrication fitting	Graisseur	
23	168279	+26.13.00	1	RG2600-55	Rillengabel	Inboard yoke	Mâchoire à gorge	
24	304578	61.06.00	2	DIN1481-13x95	Spannstift	Spring type straight pin	Goupille élastique	
25	178270	75.45.139	1	SSgeh-440	Profilrohr; gehärtet	Profile tube; hardened	Tube profilé; cémenté	
26	176894	75.46.107	1	S6-410	Profilrohr mit Schmiernippel	Profile tube with lubrication fitting	Tube profilé avec graisseur	
27	380371	63.33.00	2	7/8"	Schlag-Schmiernippel	Drive-in type lubrication fitting	Graisseur à frapper	
28	168278	+26.14.00	1	RG2600-S6	Rillengabel	Inboard yoke	Mâchoire à gorge	
51	365407	85.35.07	2	RP7	Schutzrichter mit Schraube	Guard cone with screw	Cône protecteur avec vis	
52	365305	60.15.00	2	4x10	Schraube	Screw	Vis	
53	359609	82.85.06	2		Stützring	Reinforcing collar	Bague de renfort	
54	342315	82.83.07	2		Gleitring	Bearing ring	Bague de glissement	
55	044321	82.36.03	2		Halteketten	Safety chain	Chaîne	

WALTERSCHEID

Gelenkswelle
PTO drive shaft
Transmission **W2600-SD35-610-K64/2R**

Bestell-Nr.
Part no.
Référence

Zeichnungs-Nr.
Drawing no.
Réf. du plan

Datum
Date
Date

1 2 0 1 1 9 8 8

für Kunde
for customer
pour client

Rabewerk

Kundenbezeichnung-Nr.
Customer drawing no.
Réf. du plan client

- a=Q.SG2600-1³/₈"(6)
- b=Q.SG2600-1³/₈"(21)
- c=Q.SG2600-1³/₄"(6)
- d=Q.SG2600-1³/₄"(20)

Type
Type
Type
PKE 400; SR 250-400;
SKE 300-600; Rotor
HKE, VKE

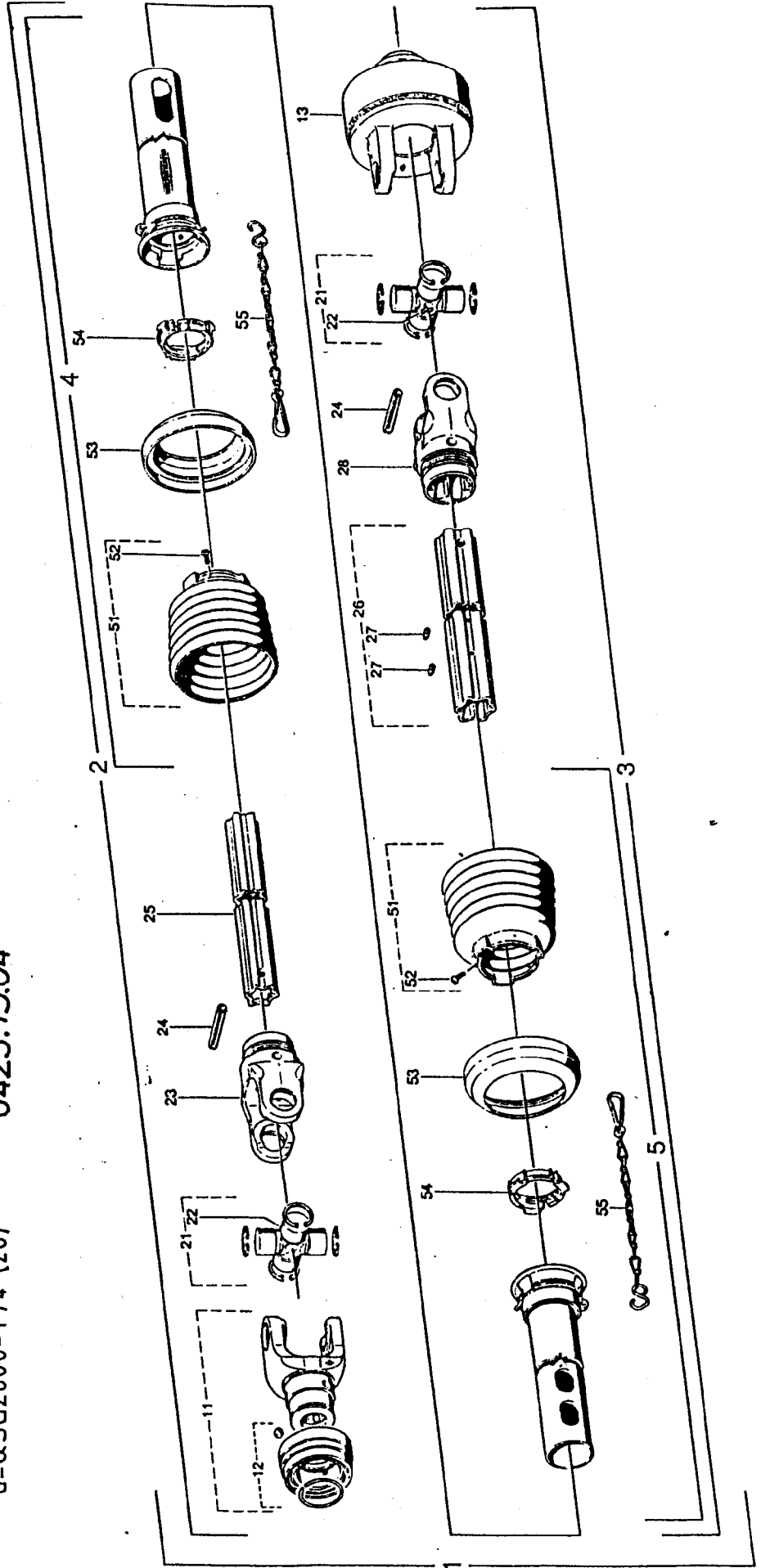

Positions-Nr. Item Position	Bestell-Nr. Part No. Reference	Zuschlags-Nr. Quantity Rate	Stückzahl Quantity Quantity	Technische Angaben Technical data Dimensions	Bezeichnung	Description	Disposition	Rabe-Nr.
1a	174175	11937	1	W2600-SD35-610-K64/2R	Gelenkwelle mit Schutz	PTO drive shaft with guard	Transmission avec protecteur	8423.15.01
1b	172365	11938	1	W2600-SD35-610-K64/2R				8423.15.02
1c	172369	11939	1	W2600-SD35-610-K64/2R				8423.15.03
1d	172373	11940	1	W2600-SD35-610-K64/2R				8423.15.04
2a	168806		1	WHZ600-SD35-507	Innere Gelenkwellenhälfte mit äußerer Schutzhälfte	Inner PTO drive shaft half with outer guard half	Demi-transmission intérieure avec demi-protecteur extérieur	8423.14.05
2b	172337		1	WHZ600-SD35-507				8423.14.06
2c	172346		1	WHZ600-SD35-507				8423.14.07
2d	172350		1	WHZ600-SD35-507				8423.14.08
3	172360		1	WHZ600-SD35-477-K64/2R	Äußere Gelenkwellenhälfte mit innerer Schutzhälfte	Outer PTO drive shaft half with inner guard half	Demi-transmission extérieure avec demi-protecteur intérieur	8423.15.05
4	178048	85.319	1	SDH35-A 340	Äußere Schutzhälfte	Outer guard half	Demi-protecteur extérieur	
5	178049	85.320	1	SDH35-J 340	Innere Schutzhälfte	Inner guard half	Demi-protecteur intérieur	
11a	365814	+26.84.00	1	Q.SGZ600-17/r(16)				
11b	365816	+26.84.02	1	Q.SGZ600-17/r(21)				
11c	365818	+26.84.04	1	Q.SGZ600-17/r(16)	Q.S-Gabel komplett	Q.S-yoke complete	Mâchoire Q.S complète	
11d	366780	+26.84.06	1	Q.SGZ600-17/r(20)				
12a	376106	agrazet 123	1					
12b	376106	agrazet 123	1					
12c	376107	agrazet 124	1					
12d	376107	agrazet 124	1					
13	377389	59.110.12	1	K64/2R-17/r(16); M=2400Nm	Q.S-Verschluss komplett; Größe C	Q.S-lock complete; size C	Verrouillage Q.S complet; type C	
21	326245	26.00.00	2		Neckenschaltkupplung komplett; Rechtsdreh Sinn	Cam-type cut out clutch complete; clockwise rotation	Limiteur débrayable à cames complet; rotation à droite	
22	084099	63.27.00	2	M8x1	Kreuzgarnitur komplett	Gross and bearing kit complete	Bloc croisillon complet	
23	168279	+26.13.00	1	RGZ600-S5	Kegel-Schmiernippel	Lubrication fitting	Graisseur	
24	304578	61.06.08	2	DIN1481-13x95	Rillengabel	Inboard yoke	Mâchoire à gorge	
25	170270	75.45.139	1	S5geh-440	Spannstift	Spring type straight pin	Goupille élastique	
26	176894	75.46.107	1	S6-410	Profilrohr, gehärtet	Profile tube, hardened	Tube profilé, cémenté	
27	380371	63.33.00	2	7/8"	Profilrohr mit Schmiernippel	Profile tube with lubrication fitting	Tube profilé avec graisseur	
28	168278	+26.14.00	1	RGZ600-S6	Schlag-Schmiernippel	Drive-in type lubrication fitting	Graisseur à frapper	
51	365407	85.35.07	2	RP7	Rillengabel	Inboard yoke	Mâchoire à gorge	
52	365305	60.15.00	2	4x10	Schutztrichter mit Schraube	Guard cone with screw	Cône protecteur avec vis	
53	359609	82.85.06	2		Schraube	Screw	Vis	
54	342315	82.83.07	2		Stützring	Reinforcing collar	Bague de renfort	
55	044321	82.36.03	2		Gleitring	Bearing ring	Bague de glissement	
			2		Halbkette	Safety chain	Chainette	

Reibkupplung
Friction clutch
Limiteur à friction

K90/4

K 90 / 4 R-2500

Einzelteile
Components
Pièces composantes

WALTERSCHEID

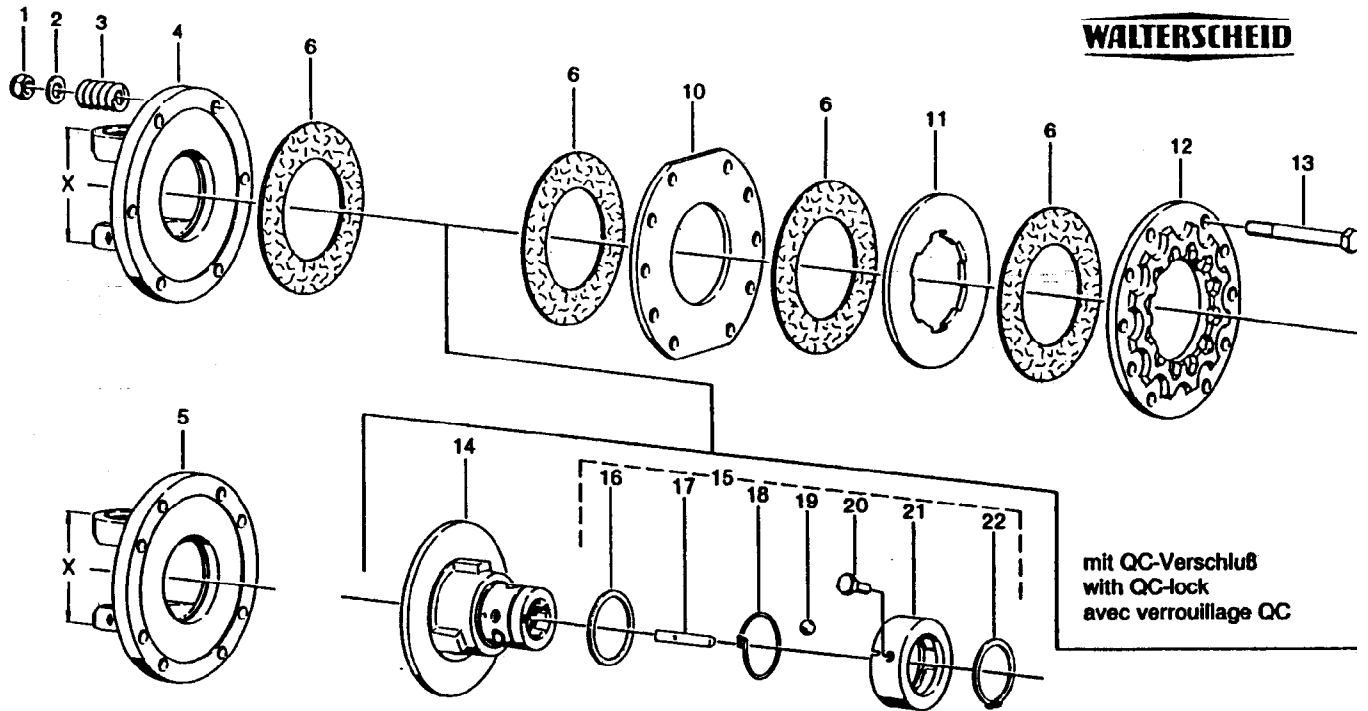

Positions-Nr. Item Repère	Baugröße Size Dimension	X mm	Ersatzteil-Nr. Spare part No. Réf. pièce de rechange	Bestell-Nr. Part No. Référence	Technische Angaben Technical data Données techniques	Benennung	Designation	Désignation
1			60.53.07	099850	DIN 985-M 12x1,25	Sechskantmutter, selbstsichernd	Self-locking hexagon nut	Ecrou hexagonal, indesserrable
2			60.75.01	020093	DIN 125-A 13	Scheibe	Washer	Rondelle
3			66.01.53	330592		Druckfeder	Compression spring	Ressort de compression
4	2400	86	35.73.01	335604	6 Bohrungen	Flanschgabel	Flange yoke	Mâchoire à bride
5	2500	100	36.73.01	335605	8 holes			
	2600	120	26.73.01	335606	8 trous			
6			56.73.00	042480	Ø91 x Ø153	Reibscheibe	Friction disk	Disque de friction
10			56.93.00	335603		Scheibe	Washer	Rondelle
11			56.94.00	335442		Mitnahmescheibe	Drive plate	Disque d'entraînement
12			56.92.00	337464		Druckscheibe	Thrust plate	Disque de pression
13			60.06.33	304062	DIN 980-M 12x1,25x110	Sechskantschraube	Hexagon screw	Boulon hexagonal
14			56.91.08	367763	1 1/4" (6)	Flanschnabe	Flange hub	Moyeu à plateau
15			agraset® 126	376109	1 1/4" (6)	QC-Verschluss kpl.	QC-lock cpl.	Verrouillage QC cpl.
16			16.20.169	376770		Scheibe	Washer	Rondelle
17			16.50.42	375309		Klemmkeil	Clamping key	Rochet de serrage
18			66.24.01	375208		Drehfeder	Torsional spring	Ressort à action angulaire
19			64.01.16	701640	DIN 5401-15mm III	Kugel	Ball	Bille
20			60.06.47	377191	M 12 x 30-10.9	Sechskantschraube, selbstsichernd	Self-locking hexagon screw	Boulon hexagonal, indesserrable
21			65.07.01	375207		Sperring	Lock ring	Manchon de verrouillage
22			62.21.01	702063	DIN 471-65 x 2,5	Sicherungsring	Retaining ring	Jonc

Für Kunde
for customer
pour client

Rabewerk

Kundenzeichnungs-Nr.
Customer drawing No.
Réf. du plan client

Maschinenart
Machine
Machine

Type
Type
Type

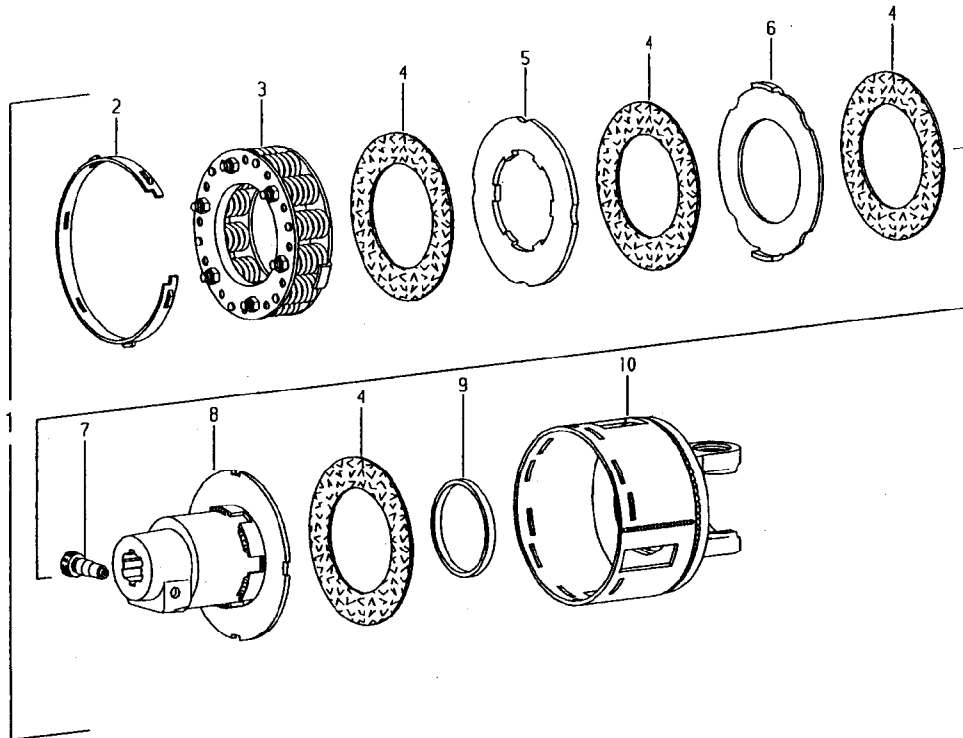

Pos.-Nr. Item Répare	Bestell-Nr. Part No. Référence	Zeichnungs-Nr. Drawing No. Réf. du Plan	Stückzahl Quantity Quantité	Technische Angaben Technical data Données techniques	Benennung	Description	Désignation
1	103190	56.133.51	1	K96/4-2600-1 3/4" (6)CC, M=1800Nm-I	Reibkupplung, drehsinnunabhängig	Friction clutch, independent of direction of rotation	Limiteur à friction, indépendant du sens de rotation
2	367720	56.36.00	1	170x15	Einstellring	Setting ring	Bague de réglage
3	377672	56.35.01	1	105/210	Federpaket, montiert	Spring pack assembly	Bloc-ressort complet
4	177009	56.73.12	4	100,5x157x3	Reibscheibe	Friction disk	Disque de friction
5	367725	56.34.02	1	160,5x88,5/97x6	Mitnahmescheibe	Drive plate	Disque d'entraînement
6	367726	56.34.03	1	161,5x100x4	Mitnahmescheibe	Drive plate	Disque d'entraînement
7	107542	65.12.08	1	CC 1 3/4"	Klemm-Konus	Clamping cone	Cone de contrainte
8	196380	56.31.18	1	K96/4-1 3/4" (6)CC	Nabe	Hub	Moyeu
9	367718	16.52.06	1	84,4x92,4x8	Lauftring	Ring	Bague
10	177116	+26.90.02	1	K96/4-2600	Kupplungsgehäuse	Clutch housing	Boîtier

Für Kunde
For customer
pour client

Rabewerk

Kundenzeichnungs-Nr.
Customer drawing No.
Réf. du plan client

Maschinenart
Machine
Machine

Type
Type
Type

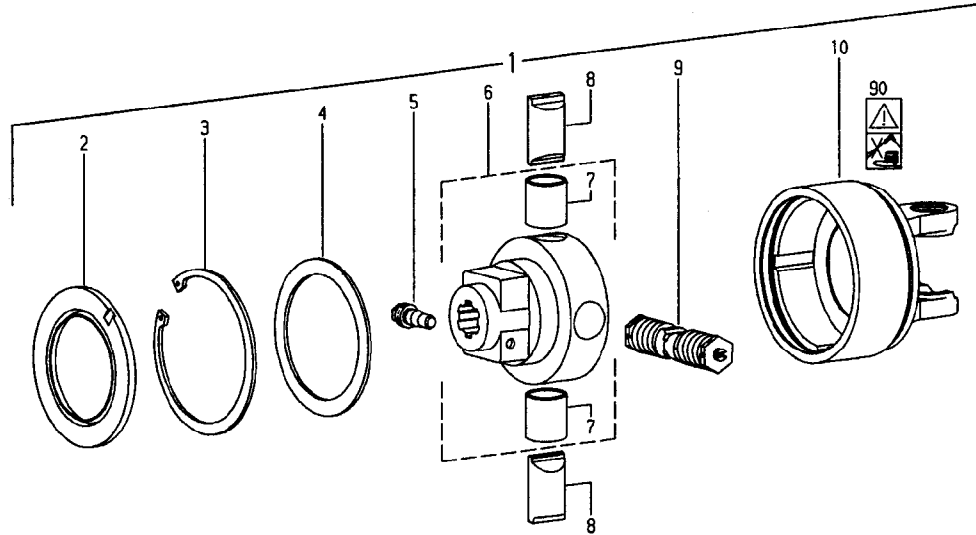

Pos.-Nr. Item Reprise	Bestell-Nr. Part No. Référence	Zeichnungs-Nr. Drawing No. Réf. du Plan	StkZahl Quantity Quantité	Technische Angaben Technical data Données techniques	Benennung	Description	Désignation
1	110495	59.155.12	1	K64/2R-2600-1 3/4" (6) CC; M=2400Nm	Nockenschaltkupplung; Rechtsdrehsinn	Cam-type cut out clutch; right-hand rotation	Limiteur débrayable à cames; rotation à droite
2	161459	68.18.01	1	152,5x39x8	Dichtring	Sealing ring	Joint
3	364499	62.46.00	1	DIN472-150x4	Sicherungsring	Retaining ring	Jonc
4	364621	16.20.81	1	5120x150x3,5	Stützscheibe	Supporting ring	Rondele pour bague de frein
5	107542	65.12.08	1	CC 1 3/4"	Klemm-Konus	Clamping cone	Cone de contrainte
6	102077	59.20.35	1	K64/2-1 3/4" (6) CC	Nabe komplett	Hub complete	Moyeu complet
7	364622	16.50.425	2	35x39x40	Buchse	Bush	Douille
8	364636	59.23.00	2	#35	Spernnocken	Locking cam	Came de blocage
9	376060	59.25.01	1	K64/2-240	Federpaket, montiert	Spring pack assembly	Bloc-ressort complet
10	377392	+26.90.04	1	K64/2R-2600	Kupplungsgehäuse, Rechtsdrehsinn	Clutch housing; right-hand rotation	Boitier; rotation a droite
90	117291	16.61.181	1		Verbotsaufkleber - Hochdruckreiniger	Prohibitive decal - high-pressure cleaner	Autocollant d'interdiction nettoyeur à haute pression

WALTERSCHEID

Kupplung
Clutch
Limiteur

EK64/2R-1 3/4" (6) CC-TK138/M12 (6); M=1600Nm

Bestell-Nr.
Part No.
Référence **110494**

Zeichnungs-Nr.
Drawing No.
Réf. du plan **59.156.12**

Datum
Date **11.07**

Für Kunde
for customer
pour client

Rabewerk

Kundenzeichnungs-Nr.
Customer drawing No.
Réf. du plan client

Maschinenart
Machine
Machine

Type
Type
Type

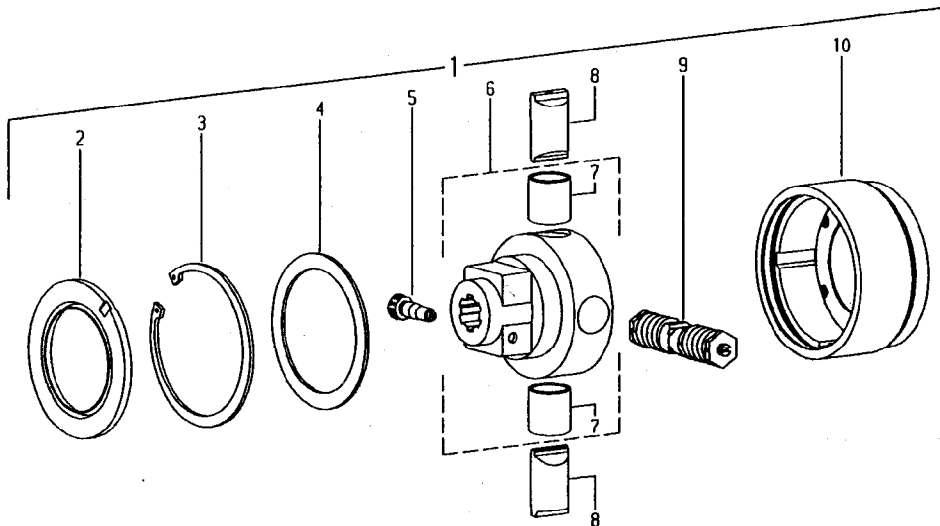

Pos.-Nr. Iss Répare	Bestell-Nr. Part No. Référence	Zeichnungs-Nr. Drawing No. Réf. du Plan	Stückzahl Quantity Quantité	Technische Angaben Technical data Données techniques	Benennung	Description	Désignation
1	110494	59.156.12	1	EK64/2R-1 3/4" (6) CC-TK138/M12 (6); M=1600Nm	Nockenschaltkupplung; Rechtsdrehsinn	Cam-type cut out clutch; right-hand rotation	Limiteur débrayable à cames; rotation à droite
2	161459	68.18.01	1	152,5x89x8	Dichtring	Sealing ring	Joint
3	364499	62.46.00	1	D1M72-150x4	Sicherungsring	Retaining ring	Jonc
4	364621	16.20.81	1	S120x150x3,5	Stützscheibe	Supporting ring	Rondelle pour bague de frein
5	107542	65.12.08	1	CC 1 3/4"	Klemm-Konus	Clamping cone	Cone de contrainte
6	102077	59.20.35	1	K64/2-1 3/4" (6) CC	Wabe komplett	Hub complete	Moyeu complet
7	364622	16.50.425	2	35x39x40	Buchse	Bush	Bouille
8	364636	59.23.00	2	#35	Spernracken	Locking cam	Came de blocage
9	375937	59.25.01	1	K64/2-160	Federpaket, montiert	Spring pack assembly	Bloc-ressort complet
10	364458	59.22.01	1	EK64/2R-TK138/M12 (6)	Kupplungsgehäuse, Rechtsdrehsinn	Clutch housing; right-hand rotation	Baltier; rotation à droite

Nockenschaltkupplung
Cam-type cut out clutch
Limiteur débrayable à cames

K64/2R EK64/2R
 rechts/right/droite

Einzelteile
Components
Pièces composant

WALTERSCHEID

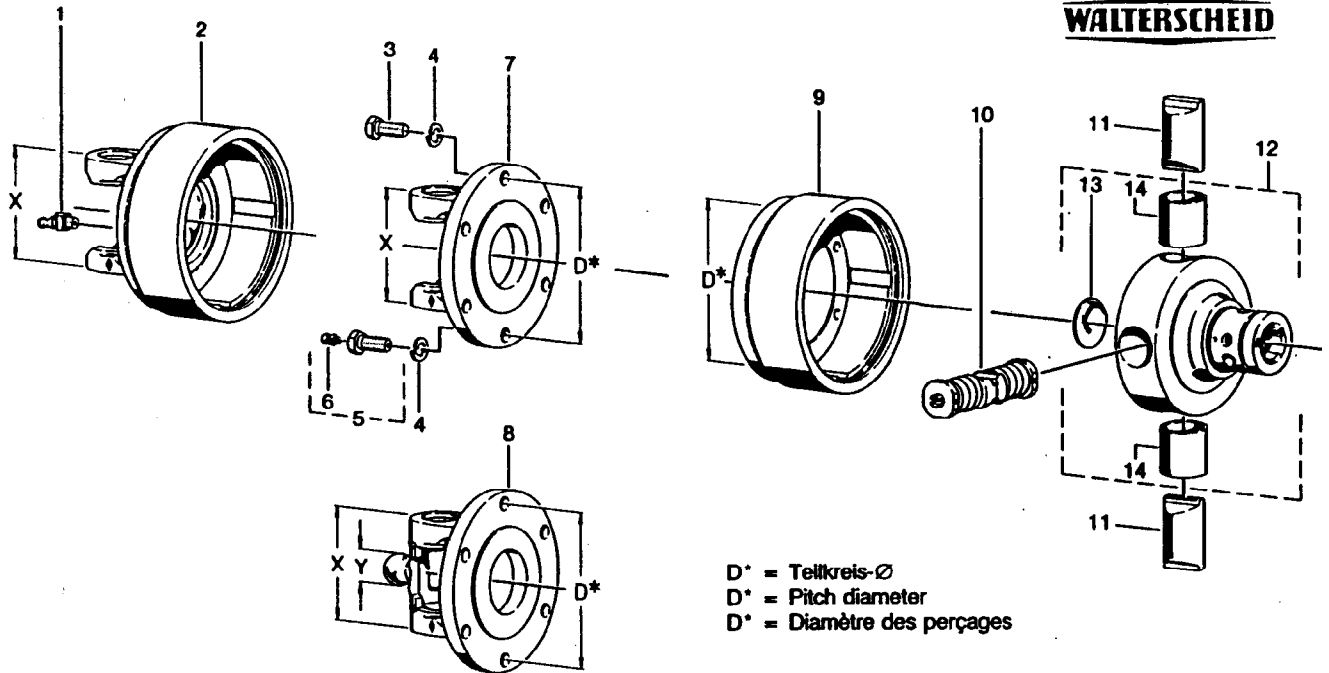

Positions-Nr. Item Repère	Baugröße Size Dimension	X mm	Y mm	D* mm	Ersatzteil-Nr. Spare part No. Réf. pièce de rechange	Bestell-Nr. Part No. Référence	Technische Angaben Technical data Données techniques	Benennung Designation	Designation	Désignation
1					63.22.01	020674	DIN 71412-BM 8x1	Kegel-Schmiemippel	Lubrication fitting	Graisseur
2	2600	120			26.90.04	377392		Kupplungsgehäuse Rechtsdreh Sinn	Clutch housing Right-hand rotation	Boîtier Rotation à droite
3	2300				60.05.26	020527	DIN 933-M 10 x 30	Sechskantschraube	Hexagon screw	Boulon hexagonal
	2400									
	2500				60.06.05	020531	DIN 933-M 12 x 30			
	2600									
4	2300				60.82.00	020105	DIN 127-A 10	Federring	Lock washer	Rondelle élastique
	2400									
	2500				60.83.00	020106	DIN 127-A 12			
	2600									
5	2300				60.05.54	377993	M 10 x 30	Sechskantschraube kpl.	Hexagon screw cpl.	Boulon hexagonal cpl.
	2400									
	2500				60.06.48	367799	M 12 x 30			
	2600									
6					63.33.00	380371	1/8"	Schlag- Schmiemippel	Drive-in type lubrication fitting	Graisseur à trapper
7	2300	83		Ø118	21.32.03	082883		Flanschgabel	Flange yoke	Mâchoire à bride
	2400	86		Ø138	35.19.02	320699				
	2500	100		Ø138	36.19.02	317807				
	2600	120		Ø138	26.15.106	334661				
8	WW2300	83	Ø18	Ø118	21.32.16	376954		Flanschgabel	Flange yoke	Mâchoire à bride
	WW2380	83	Ø24	Ø118	21.32.816	366858				
	WW2480	86	Ø27	Ø138	35.19.10	358478				
	WW2580	100	Ø30	Ø138	36.19.10	363078				
9				Ø118	59.22.00	364457		Kupplungsgehäuse Rechtsdreh Sinn	Clutch housing Right-hand rotation	Boîtier Rotation à droite
				Ø138	59.22.01	364458				
10					59.25.00	161422	M = 950 Nm	Schaltnocken kpl.	Shift cam cpl.	Came de commande cpl.
						375933	M = 1200 Nm			
						375934	M = 1300 Nm			
						375935	M = 1400 Nm			

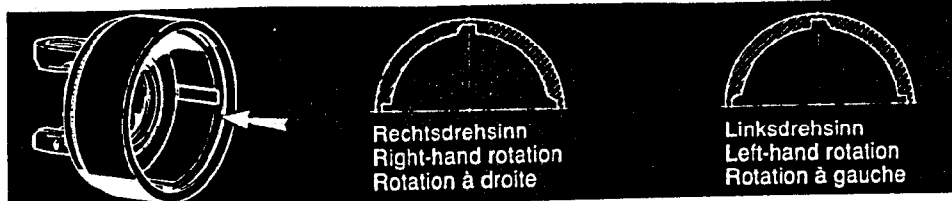

WALTERSCHEI

Nockenschaltkupplung
Cam-type cut out clutch
Limiteur débrayable à cames

K64/2R EK64/2R
rechts/right/droite

Einzelteile
Components
Pièces composantes

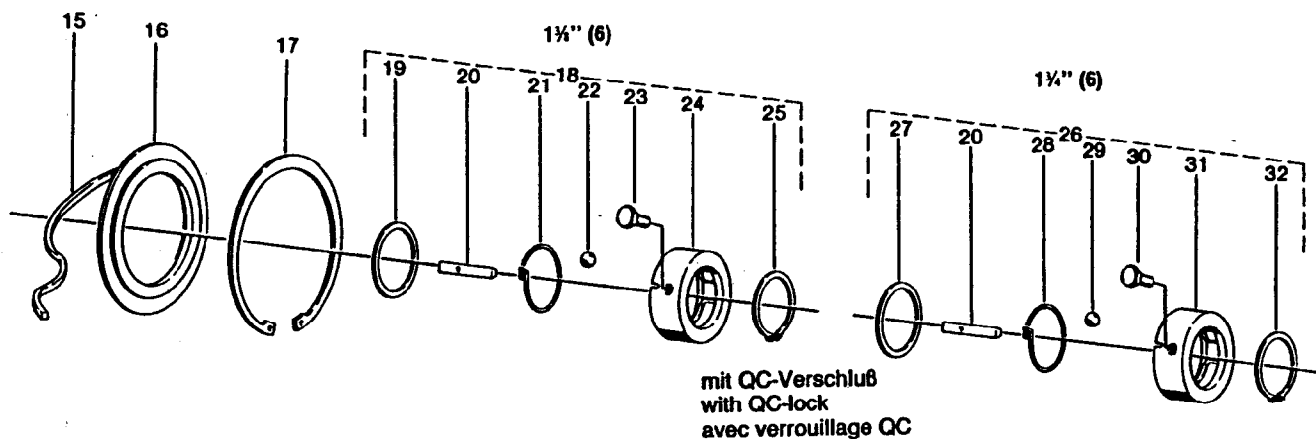

Positions-Nr. Item Réfère	Ersatzteil-Nr. Spare part No. Réf. pièce de rechange	Bestell-Nr. Part No. Référence	Technische Angaben Technical data Données techniques	Benennung	Designation	Désignation
10	59.25.00	375937	M = 1600 Nm	Schaltnocken kpl.	Shift cam cpl.	Came de commande cpl.
		375938	M = 1800 Nm			
	59.25.01	375939	M = 2000 Nm			
		368949	M = 2100 Nm			
		376060	M = 2400 Nm			
376061	M = 2500 Nm					
11	59.23.00	364636		Nocken	Cam	Came
12	59.20.09	378063	1 1/2" (6)	Nabe kpl.	Hub cpl.	Moyeu cpl.
	59.20.11	378064	1 1/2" (6)			
13	60.78.06	020990	DIN 470-45	Verschlussscheibe	Sealing washer	Couvercle de fermeture
14	16.50.425	364622	35 x 39 x 40	Buchse	Bush	Douille
15	55.94.07	376873	6 x 5 x 350	Filzstreifen	Felt strip	Joint de feutre
16	16.20.83	366569		Stützscheibe	Supporting ring	Rondelle pour bague de frein
17	62.46.00	364499	DIN 472-150 x 4	Sicherungsring	Retaining ring	Jonc
18	agraset® 125	376108	1 1/2" (6)	QC-Verschluss kpl.	QC-lock cpl.	Verrouillage QC cpl.
19	16.20.168	376769		Scheibe	Washer	Rondelle
20	16.50.42	375309		Klemmkeil	Clamping key	Rochet de serrage
21	66.24.00	375310		Drehfeder	Torsional spring	Ressort à action angulaire
22	64.01.02	020692	DIN 5401-1/2" V	Kugel	Ball	Bille
23	60.05.52	377574	M 10 x 25-10.9	Sechskantschraube, selbstsichernd	Self-locking hexagon screw	Boulon hexagonal, indesserrable
24	65.07.00	375311		Sperring	Lock ring	Manchon de verrouillage
25	62.47.00	702060	54 x 2	Sicherungsring	Retaining ring	Jonc
26	agraset® 126	376109	1 1/2" (6)	QC-Verschluss kpl.	QC-lock cpl.	Verrouillage QC cpl.
27	16.20.169	376770		Scheibe	Washer	Rondelle
28	66.24.01	375208		Drehfeder	Torsional spring	Ressort à action angulaire
29	64.01.16	701640	DIN 5401-15mm III	Kugel	Ball	Bille
30	60.06.47	377191	M 12 x 30-10.9	Sechskantschraube, selbstsichernd	Self-locking hexagon screw	Boulon hexagonal, indesserrable
31	65.07.01	375207		Sperring	Lock ring	Manchon de verrouillage
32	62.21.01	702063	DIN 471-65 x 2.5	Sicherungsring	Retaining ring	Jonc

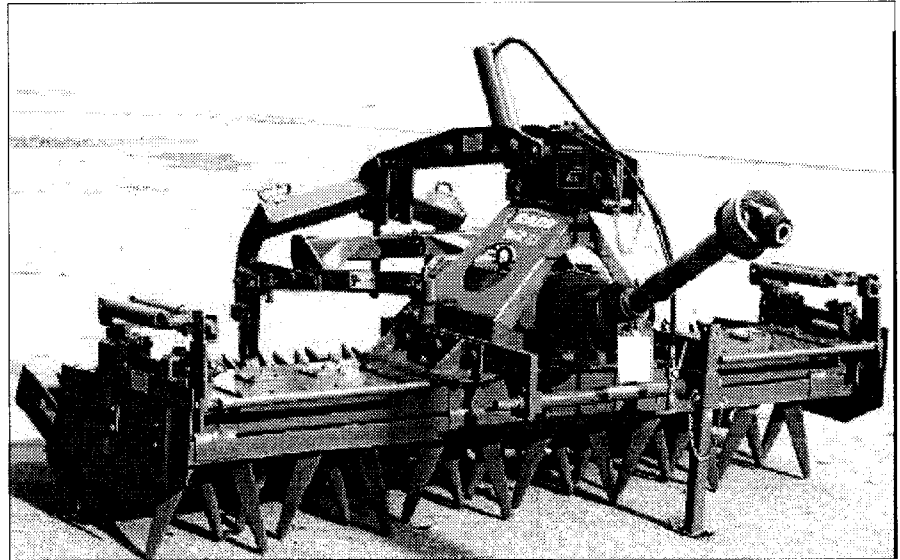

Betriebsanleitung
Ersatzteilliste

Kreiseleggen

PKE 250 u. 300 Br. 8

PKE 400 u. 450 Br. 9

